

Replacement of Seat Plate Assembly for Framework Free Standing Chairs

These instructions are for replacement of seat plate assemblies on the free standing bar height chairs, package # 53-861017-000.

1. Remove the plastic seat, package # 53-860959-000, from the existing seat plate assembly by removing the four self tapping screws, part # 11-082862-001, retain screws for later use. *Figure 1.*

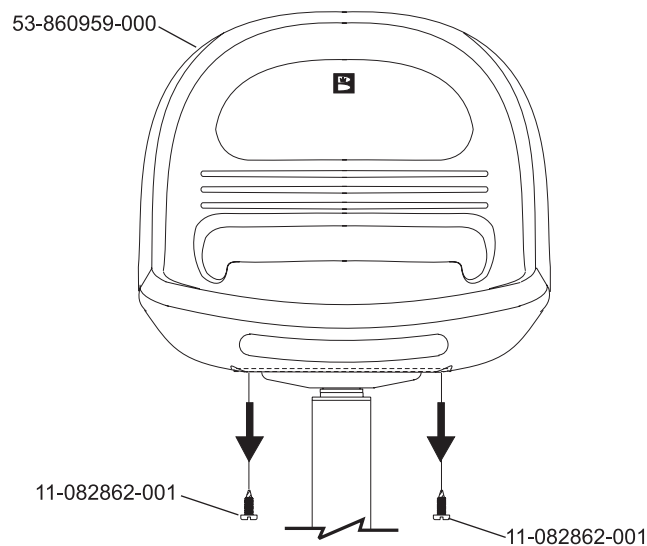

Figure 1

2. With the seat removed, use a rubber mallet to tap the underside of the seat plate assembly (tap toward center of plate) to disengage it from the column. *Figure 2.*

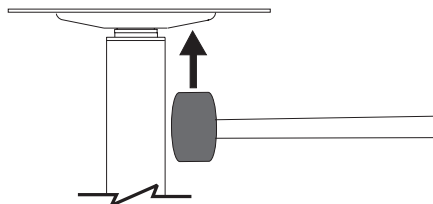

Figure 2

3. Apply a thin coating of lithium grease to the post of the new seat plate assembly, part #53-400225-000. Refer to *Figure 3*.

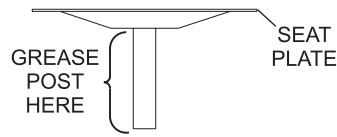

Figure 3

4. Use a rubber mallet to tap the top of the new seat plate assembly part # 53-400225-000 until it snaps into place into the column. *Figure 4*.

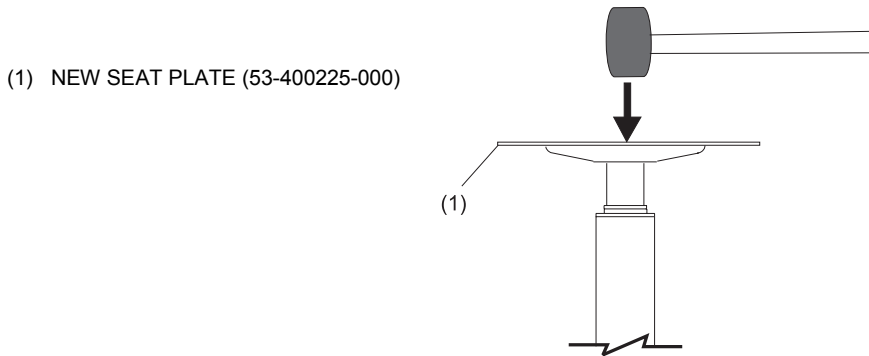

Figure 4

5. Install the plastic seat, package # 53-860959-000, by installing four self tapping screws, part # 11-082862-001. *Figure 5*.

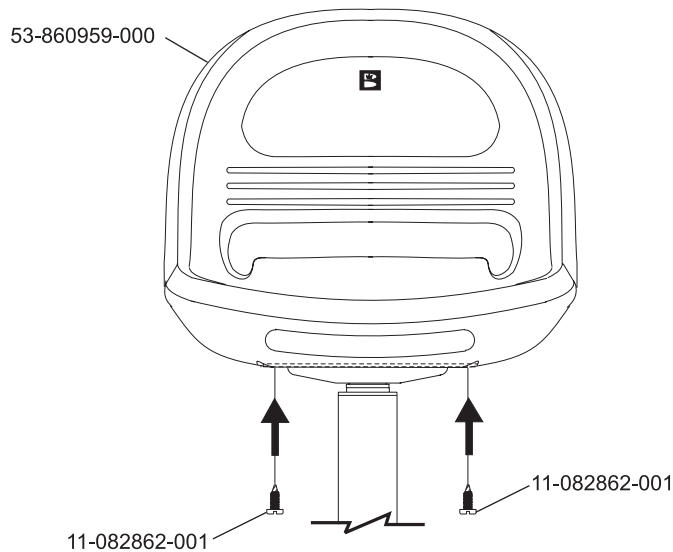

Figure 5



CAUTION: Do not use power tools to tighten screws. Do not over tighten the attaching screws! Use torque wrench making sure not to exceed the maximum torque of 25 inch lbs. (2.7nm).