

Installation Manual

Striking Line Furniture

June 2013 / 54-900223-000

Striking Line Furniture Installation Manual

© June 2013 by the Brunswick Bowling and Billiards Corporation. All rights reserved.

Past Revisions: February 2006, March 2007, January 2008

Brunswick Striking Line Furniture is a registered trademark of the Brunswick Bowling and Billiards Corporation.

Reorder Part No. 54-900223-000

Notice: If available, updates to this manual can be found on-line at www.brunswickbowling.com.

Confidential proprietary information. All information contained in this document is subject to change without notice.

Brunswick Bowling & Billiards Corporation
525 West Laketon Avenue
P.O. Box 329
Muskegon, MI 49443-0329
U.S.A.

231.725.3300

Table of Contents

Table of Contents.....	3
Safety	4
Packaging.....	5
Locating and Installing Furniture Floor Fasteners	10
Coffee Table	13
Narrow Coffee Table	15
Sofa Table.....	19
Sofa	24
Modwall	30
Optional Modwall Swing/Swivel Seats.....	36
Specifications	39

Safety

Throughout this publication, “Warnings”, and “Cautions” (accompanied by one of the International HAZARD Symbols) are used to alert the mechanic to special instructions concerning a particular service or operation that may be hazardous if performed incorrectly or carelessly. They are defined below. **OBSERVE AND READ THEM CAREFULLY!**

These “Safety Alerts” alone cannot eliminate the hazards that they signal. Strict compliance to these special instructions when performing the service, plus training and “Common Sense” operation are major accident prevention measures.



NOTE or IMPORTANT!:

Will designate significant informational notes.



WARNING!

Will designate a mechanical or nonelectrical alert which could potentially cause personal injury or death.



WARNING!

Will designate electrical alerts which could potentially cause personal injury or death.



CAUTION!

Will designate an alert which could potentially cause product damage.



Will designate grounding alerts.

SAFETY NOTICE TO USERS OF THIS MANUAL

This manual has been written and published by the Service Department of Brunswick Bowling and Billiards to aid the reader when servicing or installing the products described.

It is assumed that these personnel are familiar with, and have been trained in, the servicing or installation procedures of these products, which includes the use of common mechanic’s hand tools and any special Brunswick or recommended tools from other suppliers.

We could not possibly know of and advise the reader of all conceivable procedures by which a service might be performed and of the possible hazards and/or results of each method. We have not attempted any such wide evaluation. Therefore, anyone who uses a service procedure and/or tool, which is not recommended by Brunswick, must first completely satisfy himself that neither his nor the product’s safety will be endangered by the service procedure selected.

All information, illustrations and specifications contained in this manual are based on the latest product information available at the time of publication.

It should be kept in mind, while working on the product, that the electrical system is capable of violent and damaging short circuits or severe electrical shocks. When performing any work where electrical terminals could possibly be grounded or touched by the mechanic, the power to the product should be disconnected prior to servicing and remain disconnected until servicing is complete.

Packaging

S5-300007-XXX Coffee Table

QTY.	PART NUMBER	DESCRIPTION
1	54-861009-xxx	Package - Coffee Table Top
1	54-861011-xxx	Package - Coffee Table Legs
.125	54-861010-000	Package - Floor Mounting Hardware
1	54-861056-000	Package - Coffee Table Hardware
*1	54-861416-000	Package - Concrete Expanding Anchor Setting Tool
*1	54-900223-000	Striking Line Furniture Installation Manual
*1	54-900131-000	Striking line Furniture Service Manual

* = One Per Center

54-861010-000 Coffee Table, Floor Mounting Hardware

QTY.	PART NUMBER	DESCRIPTION
16	11-111560-000	3/8-16 x 1-9/16" Hilti Concrete Anchor
16	11-001362-001	3/8-16 x 4-1/2" Hex Head Cap Screw
16	11-191014-001	3/8 Flat Washer

54-861056-000 Coffee Table, Hardware

QTY.	PART NUMBER	DESCRIPTION
6	11-053784-001	M6 x 1.0 mm x 40 mm Pan Head Phillips Screw
6	11-052023-001	M6 Flat Washer
6	54-200031-000	Glides

S5-300031-xxx Narrow Coffee Table

QTY.	PART NUMBER	DESCRIPTION
1	54-861093-000	Package - Narrow Coffee Table Legs & Glides
1	54-861094-xxx	Package - Narrow Coffee Table Top and Shelf
1	54-861095-000	Package - Narrow Coffee Table Hardware
.167	54-861010-000	Package - Floor Mounting Hardware
*1	54-861416-000	Package - Concrete Expanding Anchor Setting Tool
*1	54-900223-000	Striking Line Furniture Installation Manual
*1	54-900131-000	Striking line Furniture Service Manual

* = One Per Center

54-861093-000 Narrow Coffee Table Legs & Glides

QTY.	PART NUMBER	DESCRIPTION
4	54-200061-000	Leg Assembly
2	54-200032-000	Oval Glide
2	54-200062-000	Round Glide
4	11-051706-001	M12 Hex Nut

54-861094-xxx Narrow Coffee Table Top & Shelf

QTY.	PART NUMBER	DESCRIPTION
1	54-200059-xxx	Table Top
1	54-200060-xxx	Shelf

54-861095-000 Narrow Coffee Table Hardware

QTY.	PART NUMBER	DESCRIPTION
4	11-054801-009	M8 x 1.25 mm x 20 mm Button Head Cap Screw
4	11-054812-009	M8 x 1.25 mm x 25 mm Button Head Cap Screw

S5-300008-xxx Sofa Table

QTY.	PART NUMBER	DESCRIPTION
1	54-861013-xxx	Package - Sofa Table Top
1	54-861014-xxx	Package - Sofa Table Legs
1	54-861015-xxx	Package - Sofa Table Leg Brace
1.25	54-861016-000	Package - Floor Mounting Hardware
1	54-861057-000	Package - Sofa Seat, Hardware
*1	54-861416-000	Package - Concrete Expanding Anchor Setting Tool
*1	54-900223-000	Striking Line Furniture Installation Manual
*1	54-900131-000	Striking line Furniture Service Manual

* = One Per Center

54-861057-000 Sofa Table, Hardware

QTY.	PART NUMBER	DESCRIPTION
10	11-054803-004	M6 x 1.0 mm x 10 mm Button Head Cap Screw
12	11-054806-004	M6 x 1.0 mm x 25 mm Button Head Cap Screw
4	11-054807-004	M6 x 1.0 mm x 40 mm Button Head Cap Screw
16	11-055526-004	M6 x 1.0 mm Acorn Nut
3	11-051706-001	M12 x 1.75 mm Hex Nut
3	54-200032-000	Glides

54-861016-000 Sofa Table, Floor Mounting Hardware

QTY.	PART NUMBER	DESCRIPTION
16	11-111560-000	3/8-16 x 1-9/16" Hilti Concrete Anchor
16	53-400301-002	3/8-16 x 1" Button Head Socket Cap Screw
16	11-191014-009	3/8 Flat Washer

54-861014-000 Sofa Table, Legs

QTY.	PART NUMBER	DESCRIPTION
1	54-8610019-xxx	Sofa Table Leg, R.H.
1	54-8610020-xxx	Sofa Table Leg, L.H.
1	54-8610021-xxx	Sofa Table Leg, Center

54-861016-000 Sofa Table Leg, Braces

QTY.	PART NUMBER	DESCRIPTION
2	54-8610017-xxx	Sofa Table Leg Brace, Short
1	54-8610018-xxx	Sofa Table Leg Brace, Long

54-861002-000 Sofa Floor Mounting, Hardware

QTY.	PART NUMBER	DESCRIPTION
16	11-111560-000	3/8-16 x 1-9/16" Hilti Concrete Anchor
16	11-006346-009	3/8-16 x 1-1/4" Button Head Socket Cap Screw
32	11-191014-001	3/8 Flat Washer

S5-300001-xxx Sofa Arm Assembly, R.H.

QTY.	PART NUMBER	DESCRIPTION
1	54-861001-xxx	Armrest Assembly, R.H.
1.25	54-861002-000	Floor Mounting Hardware
*1	54-861416-000	Package - Concrete Expanding Anchor Setting Tool

* = One Per Center

S5-300002-xxx Sofa Arm, Assembly, L.H.

QTY.	PART NUMBER	DESCRIPTION
1	54-861003-xxx	Armrest Assembly, L.H.

S5-300003-xxx Sofa Back Rest, Assembly

QTY.	PART NUMBER	DESCRIPTION
1	54-861004-xxx	Back Rest Assembly

S5-300004-xxx Sofa Seat, Assembly

QTY.	PART NUMBER	DESCRIPTION
1	54-861005-xxx	Seat Assembly
1	54-861055-000	Package - Seat Hardware

54-861055-000 Sofa Seat, Hardware

QTY.	PART NUMBER	DESCRIPTION
24	11-051891-000	M4 x 17 mm Pan Head Phillips Screw
4	11-051509-009	M6 x 1.0 mm x 12 mm Socket Head Cap Screw
12	11-051566-009	M6 x 1.0 mm x 40 mm Socket Head Cap Screw
6	11-051567-009	M8 x 1.25 mm x 70 mm Socket Head Cap Screw
2	11-051576-000	M8 x 1.25 mm x 90 mm Socket Head Cap Screw
4	11-053786-009	M6 x 1.0 mm x 12 mm Pan Head Phillips Screw
16	11-052023-001	M6 Flat Washer
8	11-052003-001	M8 Flat Washer
8	54-200010-000	Glides

S5-300009-xxx Modwall

QTY.	PART NUMBER	DESCRIPTION
1	54-861022-xxx	Package - Table Top
2	54-861074-000	Package - Ball Rack
1	54-861024-xxx	Package - Vertical Panels
1	54-861068-xxx	Package - Feet
1.25	54-861026-000	Package - Floor Mounting Hardware
*1	54-861416-000	Package - Concrete Expanding Anchor Setting Tool
*1	54-900223-000	Striking Line Furniture Installation Manual
1	54-861058-000	Package - Modwall Hardware
1	54-861069-000	Package - Modwall Bumbers
1	54-861070-000	Package - Modwall Coat Hooks and Screws
1	54-861073-000	Package - Modwall Foot Rest Brackets & Hardware
*1	54-900131-000	Striking Line Furniture Service Manual
1	54-861090-000	Package - Modwall Foot Rest Rail

* = One Per Center

54-861026-000 Modwall, Floor Mounting Hardware

QTY.	PART NUMBER	DESCRIPTION
16	11-111560-000	3/8-16 x 1-9/16" Hilti Concrete Anchor
16	53-400301-002	3/8-16 x 1" Button Head Socket Screw - Special
32	11-191014-001	3/8 Flat Washer

54-861058-000 Modwall, Hardware

QTY.	PART NUMBER	DESCRIPTION
5	11-054807-004	M6 x 40 mm Button Head Cap Screw
5	11-055526-004	M6 Acorn Nut
19	11-054809-004	M8 x 30 mm Button Head Cap Screw
25	11-054810-004	M8 x 55 mm Button Head Cap Screw
7	11-052553-001	M8 x 30 mm Flat Head Phillips Screw

54-861070-000 Modwall Coat Hook & Mounting Hardware

QTY.	PART NUMBER	DESCRIPTION
16	54-200033-000	Coat Hook
34	11-053785-004	M4 x 10 mm Pan Head Machine Screw

54-861073-000 Modwall Foot Rest Brackets and Mounting Hardware

2	54-200014-000	Foot Rest Bracket
4	11-055526-004	M6 Acorn Nut
4	11-054808-004	M6 x 45 mm Button Head Cap Screw
2	11-052812-009	M8 x 10 mm Set Screw

S5-3000021-xxx Modwall with Attached Seating (Wood Seats)

QTY.	PART NUMBER	DESCRIPTION
1	54-861049-001	Package - Swing/Swivle Modwall Assembly
1	54-861040-xxx	Package - Bar Stool - Bucket Only - Florence Style

S5-3000023-xxx Modwall with Attached Seating (Wood Seats)

QTY.	PART NUMBER	DESCRIPTION
1	54-861049-001	Package - Swing/Swivle Modwall Assembly
1	54-861042-xxx	Package - Bar Stool - Bucket Only - Contessa Style

S5-3000025-xxx Modwall with Attached Seating (Wood Seats)

QTY.	PART NUMBER	DESCRIPTION
1	54-861049-001	Package - Swing/Swivle Modwall Assembly
1	54-861044-xxx	Package - Bar Stool - Bucket Only - Catalina Style

S5-3000027-xxx Modwall with Attached Seating (Wood Seats)

QTY.	PART NUMBER	DESCRIPTION
1	54-861049-001	Package - Swing/Swivle Modwall Assembly
1	54-861046-xxx	Package - Bar Stool - Bucket Only - Voltaire 830B Style

S5-3000029-xxx Modwall with Attached Seating (Wood Seats)

QTY.	PART NUMBER	DESCRIPTION
1	54-861049-001	Package - Swing/Swivle Modwall Assembly
1	54-861048-xxx	Package - Bar Stool - Bucket Only - Voltaire 830D Style

54-861049-xxx Modwall, Swing/Swivel Assembly

QTY.	PART NUMBER	DESCRIPTION
1	54-200002-xxx	Lower T-Post, Swing/Swivel Assembly
1	53-400445-xxx	Upper T-Post, Swing/Swivle Assembly
2	53-400301-002	3/8-16 x 1" Button Head Socket Screw (for use on floor)
2	11-006345-000	3/8-16 x 1" Button Head Socket Screw (for use with Table Top)
2	11-095014-000	3/8-16 x .984" Hex Drive Insert
2	11-111560-000	Anchor - Expanding Concrete
2	11-191012-001	5/16 Plain Washer (for shimming if necessary)

S5-300011-xxx Bar Height Chair (Wood Seat)

QTY.	PART NUMBER	DESCRIPTION
1	54-861030-xxx	Package - Bar Stool - Florence Style (complete Stool)

S5-300013-xxx Bar Height Chair (Wood Seat)

QTY.	PART NUMBER	DESCRIPTION
1	54-861032-xxx	Package - Bar Stool - Contessa Style (complete Stool)

S5-300015-xxx Bar Height Chair (Wood Seat)

QTY.	PART NUMBER	DESCRIPTION
1	54-861034-xxx	Package - Bar Stool - Catalina Style (complete Stool)

S5-300017-xxx Bar Height Chair (Wood Seat)

QTY.	PART NUMBER	DESCRIPTION
1	54-861036-xxx	Package - Bar Stool - Voltaire 830B Style (complete Stool)

S5-300019-xxx Bar Height Chair (Wood Seat)

QTY.	PART NUMBER	DESCRIPTION
1	54-861038-xxx	Package - Bar Stool - Voltaire 830D Style (complete Stool)

Locating and Installing Furniture Floor Fasteners

All bowler area and concourse furniture is located (in most cases) off of the center line of the division capping.

Concrete Floors

1. Place the furniture in the desired positions as shown on the layout chosen for the center. Mark the location of the attaching holes for the leg assembly on the floor. Move the furniture to obtain access to the marked fastener holes.



NOTE:

*If the area where the furniture is to be installed is carpeted, it will be necessary to remove a 3/4" (19 mm) diameter patch of carpet where the 1/2" (13 mm) faster hole will be drilled. **Be careful when drilling the hole, not to catch and rip the carpet with the drill bit.***

2. Drill a 1/2" (13 mm) hole, 1-5/8" (41 mm) deep, at the attaching hole locations marked on the floor.
Figure 1.

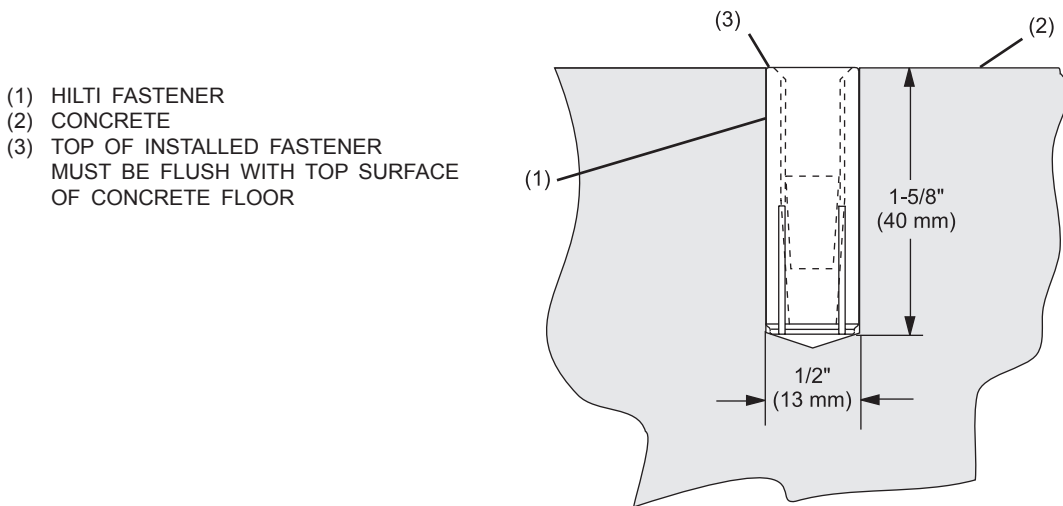

Figure 1

3. Adjust depth gauge so anchor will be flush with the base material surface. Refer to Figure 2-A.

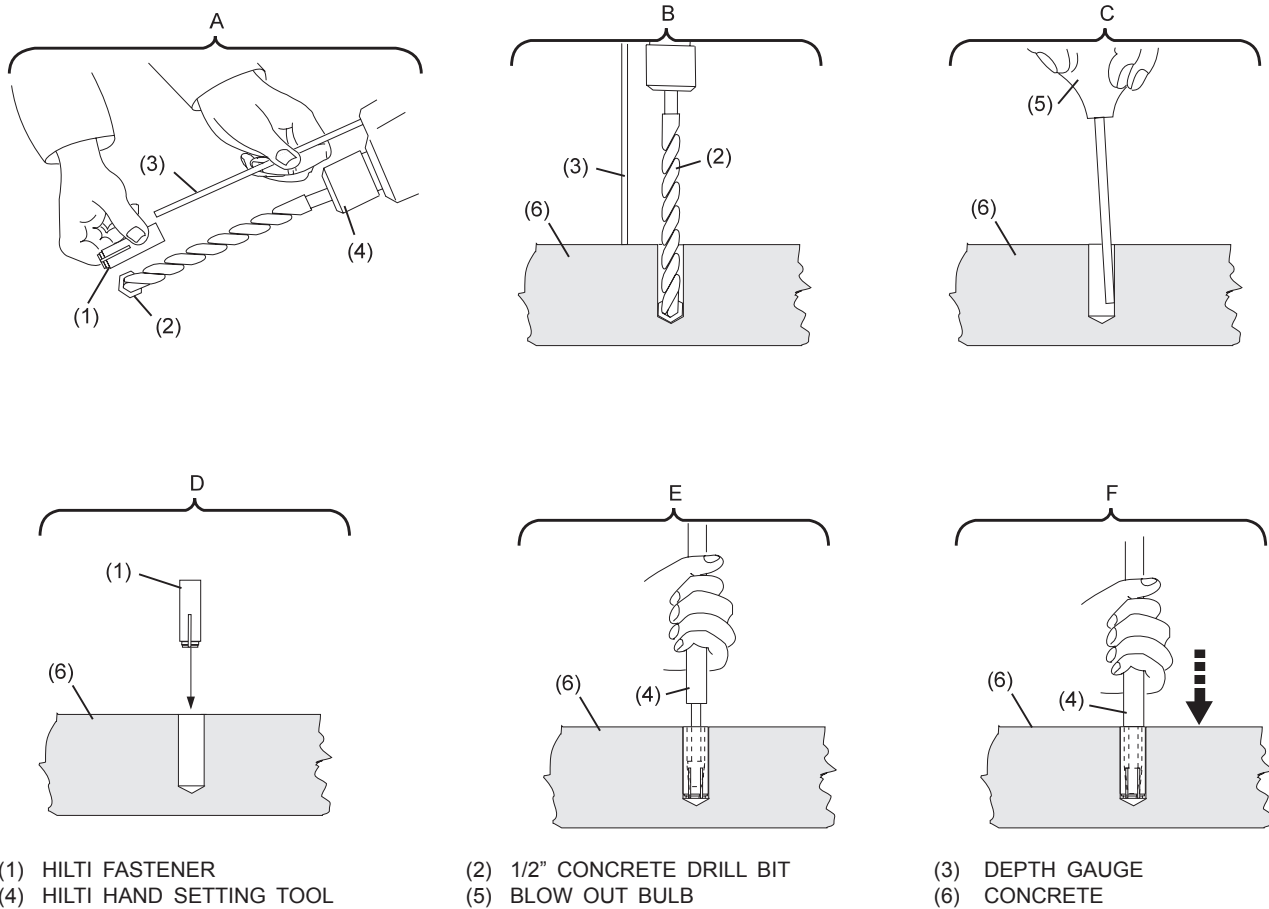

Figure 2

4. Hammer drill the hole. *Figure 2-B.*

5. Clean hole with blowout bulb. *Figure 2-C.*

6. Place fastener in hole with threaded end up until flush with concrete. *Figure 2-D.*

7. Install anchor using Hilti hand setting tool, package number 57-861416-000, which was included in your shipment. Setting tool to be driven into anchor until setting tool shoulder meets top of anchor. *Figures 2-E and 2-F.*

Wood Floors

1. Place the furniture in the desired positions as shown on the layout chosen for the center. Mark the locations of the attaching holes for the leg assembly, on the floor.
2. Drill $5/8''$ (16 mm) holes, $1-5/16''$ (33 mm) deep at the marked locations. The hole must be slightly deeper than the length of the fastener. *Figure 4.*

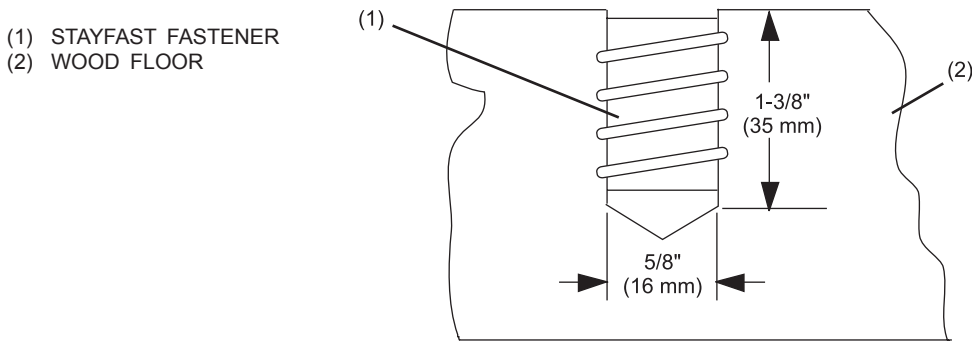

Figure 4



NOTE:

*If the area where the furniture is to be installed is carpeted, it will be necessary to remove a $3/4''$ (19 mm) diameter patch of carpet where the $1/2''$ (13 mm) faster hole will be drilled. **Be careful when drilling the hole, not to catch and rip the carpet with the drill bit.***

3. Align the fastener with the drilled hole and using a 10 mm hex drive wrench, screw the fastener into the wood floor until its top surface is slightly below the top surface of the floor. *Figure 4.*

Coffee Table

Coffee Table Components

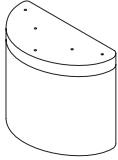
ITEM	PART NUMBER	DESCRIPTION	QTY	ILLUSTRATION
C1	54-861009-XXX	TOP	1	
C2	54-861010-XXX	LEG	2	

Coffee Table Hardware

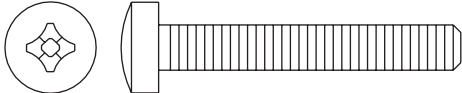
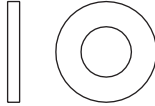
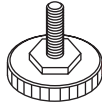
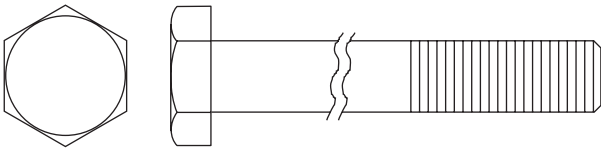
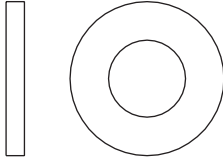
ITEM	PART NUMBER	DESCRIPTION	QTY	ILLUSTRATION
H1	11-053784-001	M6 x 1.0 40mm LG PAN HEAD PHILLIPS SCREW	6	
H2	11-052023-001	M6 FLAT WASHER	6	
H3	54-200031-000	FLAT GLIDE W/ M8X27mm, BLACK	6	
H4	11-001362-001	HEX HD SCREW 3/8-16 X 4-1/2 LG	2	
H5	11-191014-001	3/8 FLAT WASHER	2	

Torque Specifications

ITEM	TORQUE SPEC
T75	75 INCH POUNDS (8.5 NEWTON METRES)
T100	100 INCH POUNDS (11.3 NEWTON METRES)



CAUTION!

Over-tightening fasteners can result in product damage.

Coffee Table Assembly



WARNING!

All Brunswick furniture must be secured properly to the floor before being put into service. Unsecured furniture can tip causing injury!

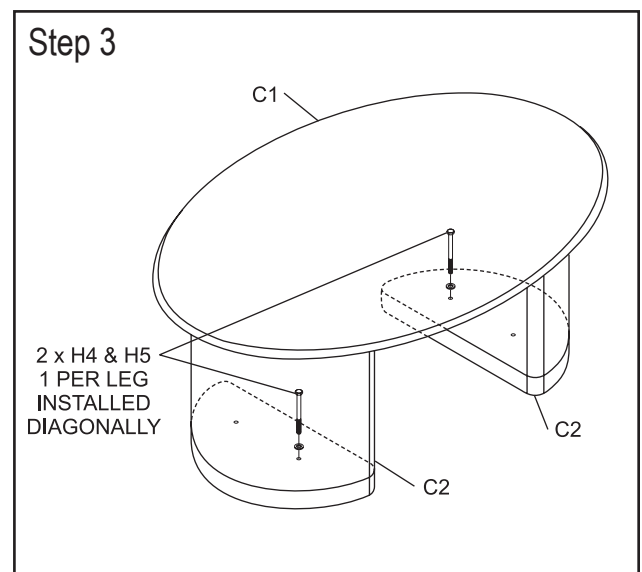
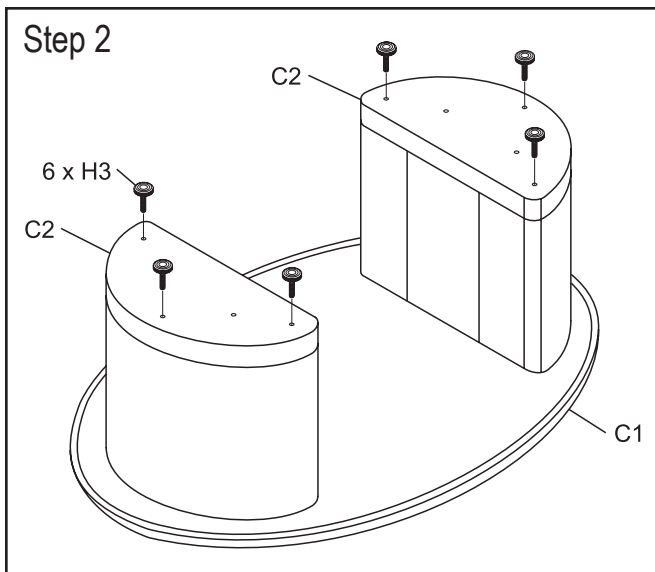
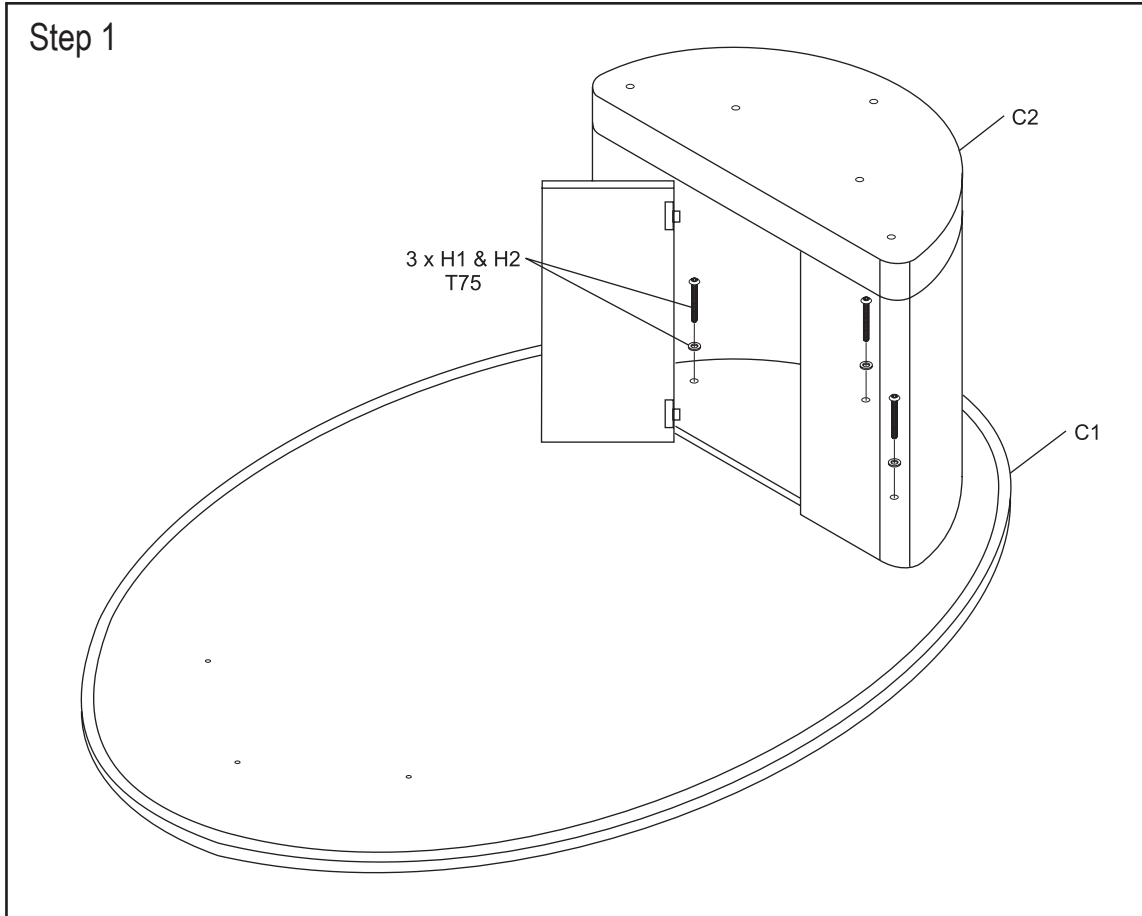

Narrow Coffee Table

Narrow Coffee Table Components

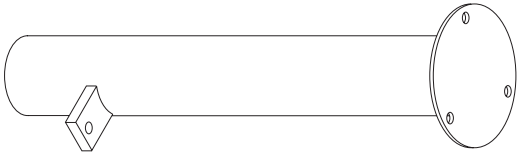
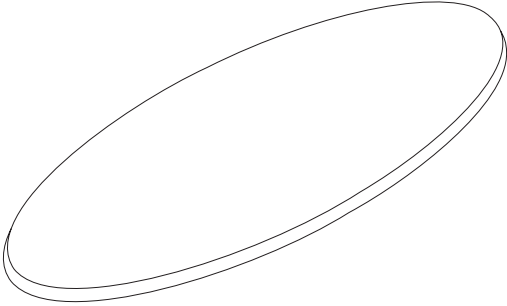
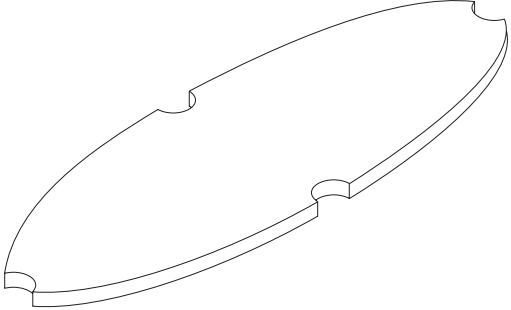
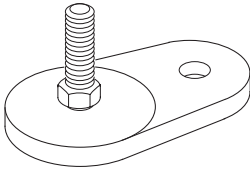
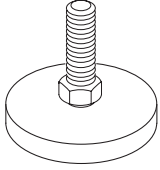
ITEM	PART NUMBER	DESCRIPTION	QTY	ILLUSTRATION
C1	54-200061-000	LEG	4	
C2	54-200059-XXX	TABLE TOP	1	
C3	54-200060-XXX	LOWER SHELF	1	
C4	54-200032-000	OVAL GLIDE	2	
C5	54-200062-000	ROUND GLIDE	2	

Narrow Coffee Table Hardware

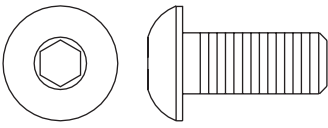
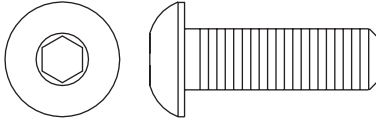
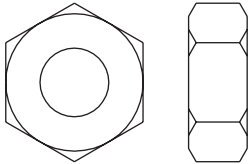
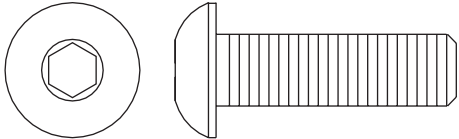
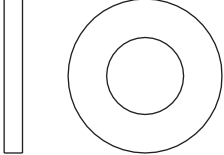
ITEM	PART NUMBER	DESCRIPTION	QTY	ILLUSTRATION
H1	11-054801-009	M8 x 1.25 x 20mm LG BTN HEAD CAP SCREW	12	
H2	11-054812-009	M8 x 1.25 x 25mm LG BTN HEAD CAP SCREW	4	
H3	11-051706-001	M12 x 1.75 HEX NUT	4	
H4	11-006354-009	3/8-16 x 1-1/4 LG BTN HEAD CAP SCREW	2	
H5	11-191014-009	3/8 FLAT WASHER	2	

Torque Specifications

ITEM	TORQUE SPEC
T75	75 INCH POUNDS (8.5 NEWTON METRES)
T100	100 INCH POUNDS (11.3 NEWTON METRES)



CAUTION!

Over-tightening fasteners can result in product damage.

Narrow Coffee Table Assembly



WARNING!

All Brunswick furniture must be secured properly to the floor before being put into service. Unsecured furniture can tip causing injury!

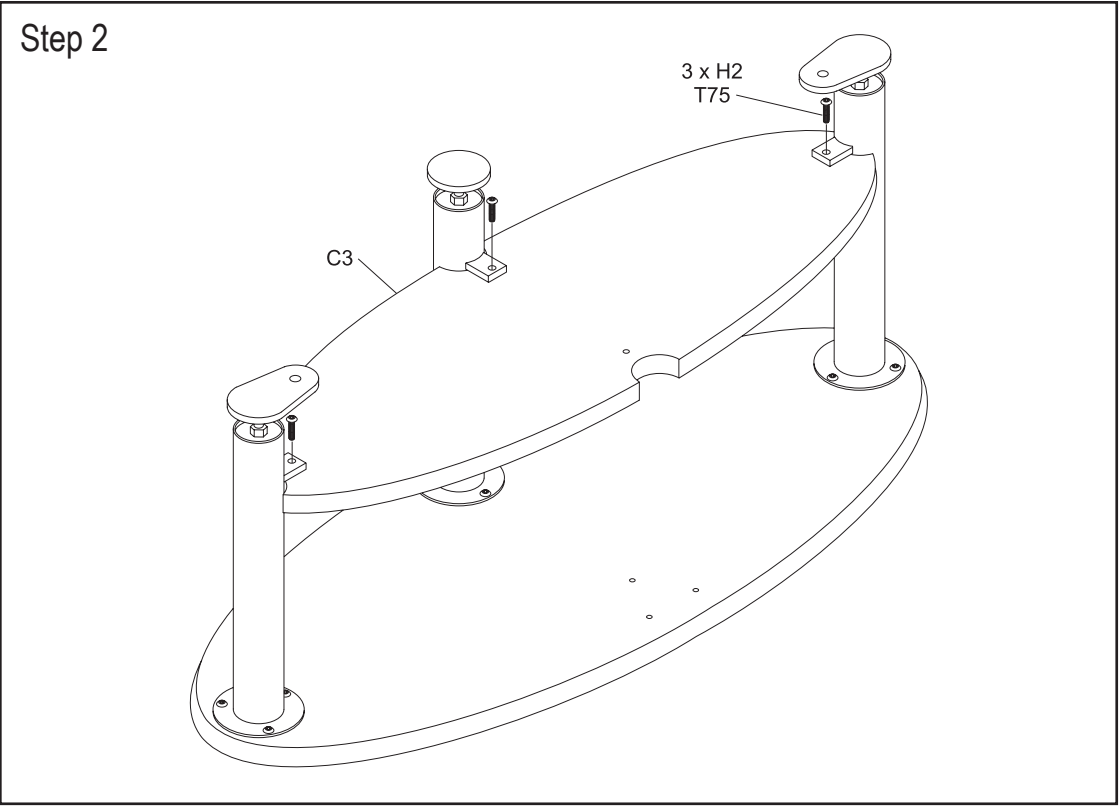
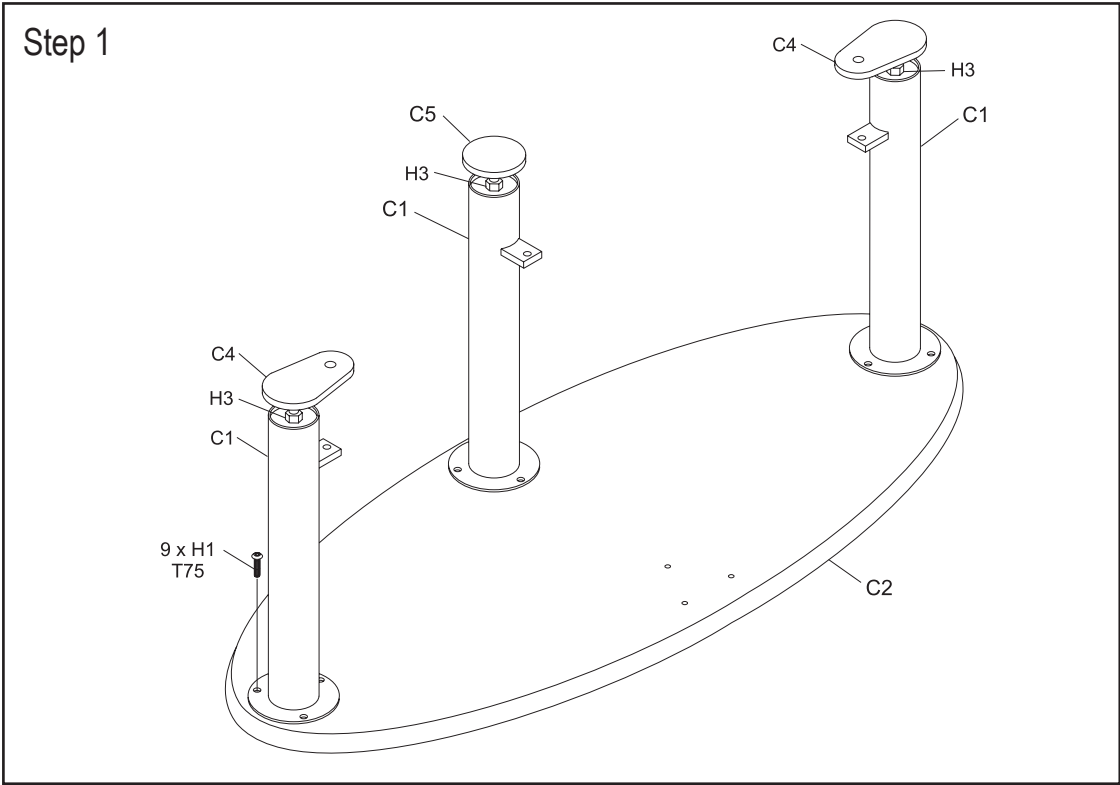

Step 3

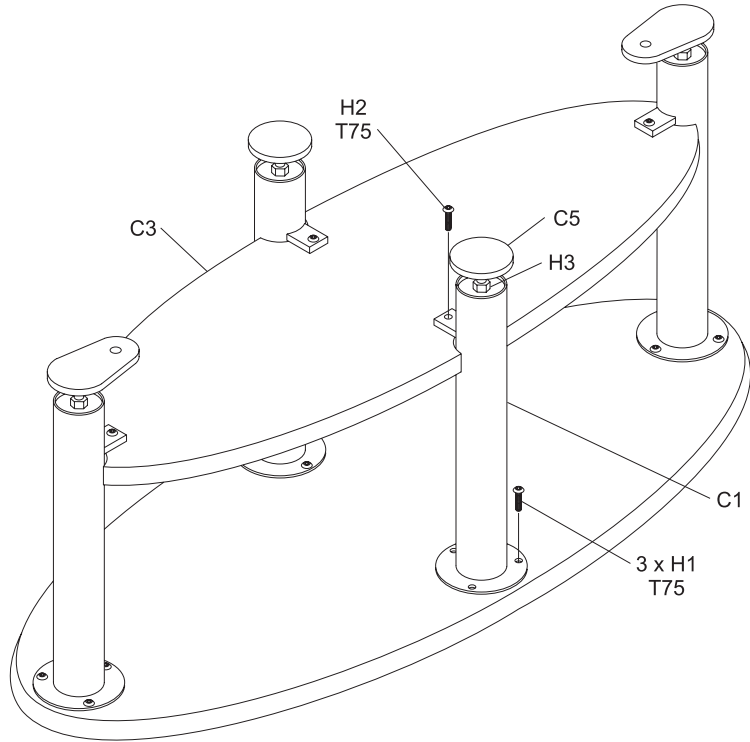

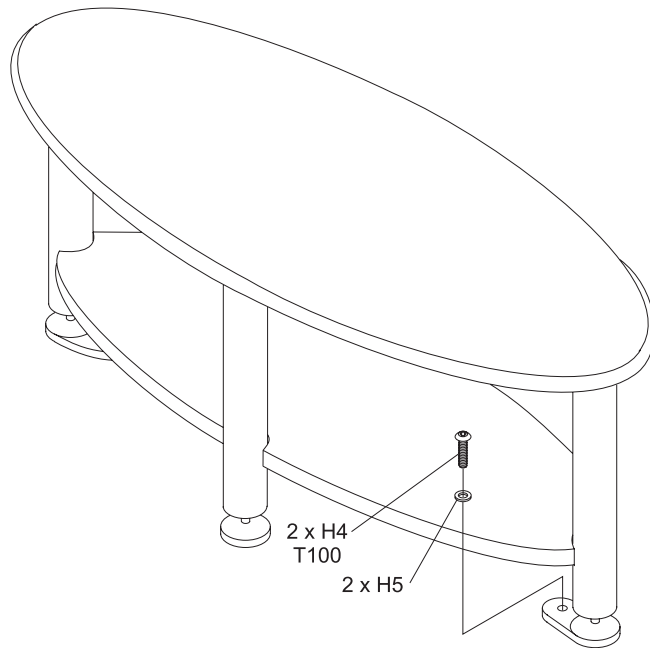

Step 4

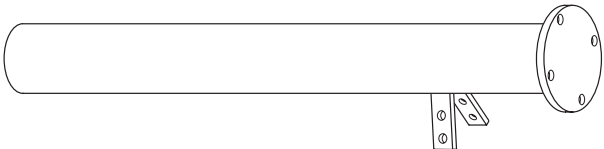
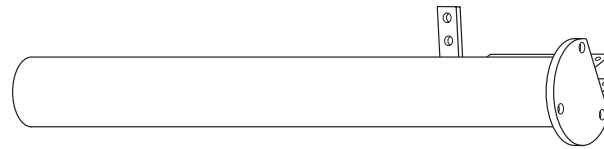
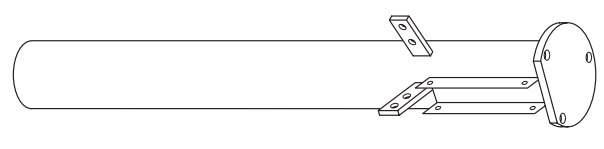

Sofa Table

Sofa Table Components

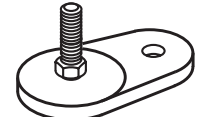
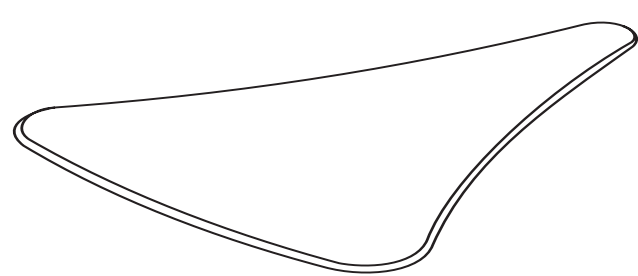
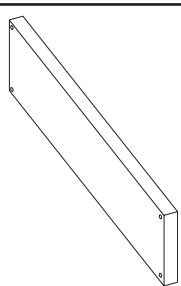
ITEM	PART NUMBER	DESCRIPTION	QTY	ILLUSTRATION
C1	54-861021-XXX	BACK LEG	1	
C2	54-861020-XXX	FRONT LEFT LEG	1	
C3	54-861019-XXX	FRONT RIGHT LEG	1	
C4	54-861017-XXX	LEG BRACE	2	
C5	54-861018-XXX	SHORT LEG BRACE	1	
C6	54-200032-000	FLAT GLIDE	3	
C7	54-861013-XXX	TABLE TOP	1	
C8	54-861055-XXX	FRONT DECORATIVE BOARD	1	

Sofa Table Hardware

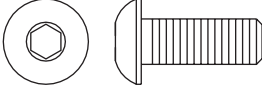
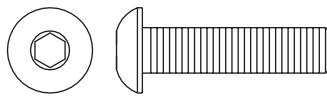
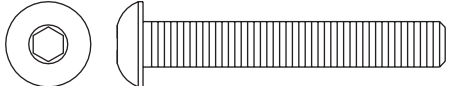
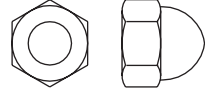
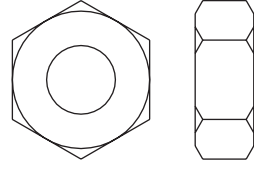
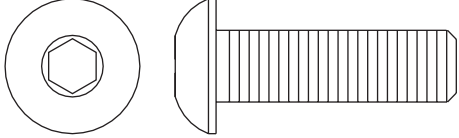
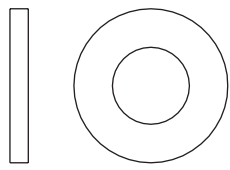
ITEM	PART NUMBER	DESCRIPTION	QTY	ILLUSTRATION
H1	11-054803-004	M6 x 1.0 16mm LG BTN HEAD CAP SCREW	10	
H2	11-054806-004	M6 x 1.0 25mm LG BTN HEAD CAP SCREW	12	
H3	11-054807-004	M6 x 1.0 40mm LG BTN HEAD CAP SCREW	4	
H4	11-055526-004	M6 x 1.0 ACORN NUT	16	
H5	11-051706-001	M12 x 1.75 HEX NUT	3	
H6	11-006354-009	3/8-16 x 1-1/4 LG BTN HEAD CAP SCREW	3	
H7	11-191014-009	3/8 FLAT WASHER	3	

Torque Specifications

ITEM	TORQUE SPEC
T75	75 INCH POUNDS (8.5 NEWTON METRES)
T100	100 INCH POUNDS (11.3 NEWTON METRES)



CAUTION!

Over-tightening fasteners can result in product damage.

Sofa Table Assembly



WARNING!

All Brunswick furniture must be secured properly to the floor before being put into service. Unsecured furniture can tip causing injury!

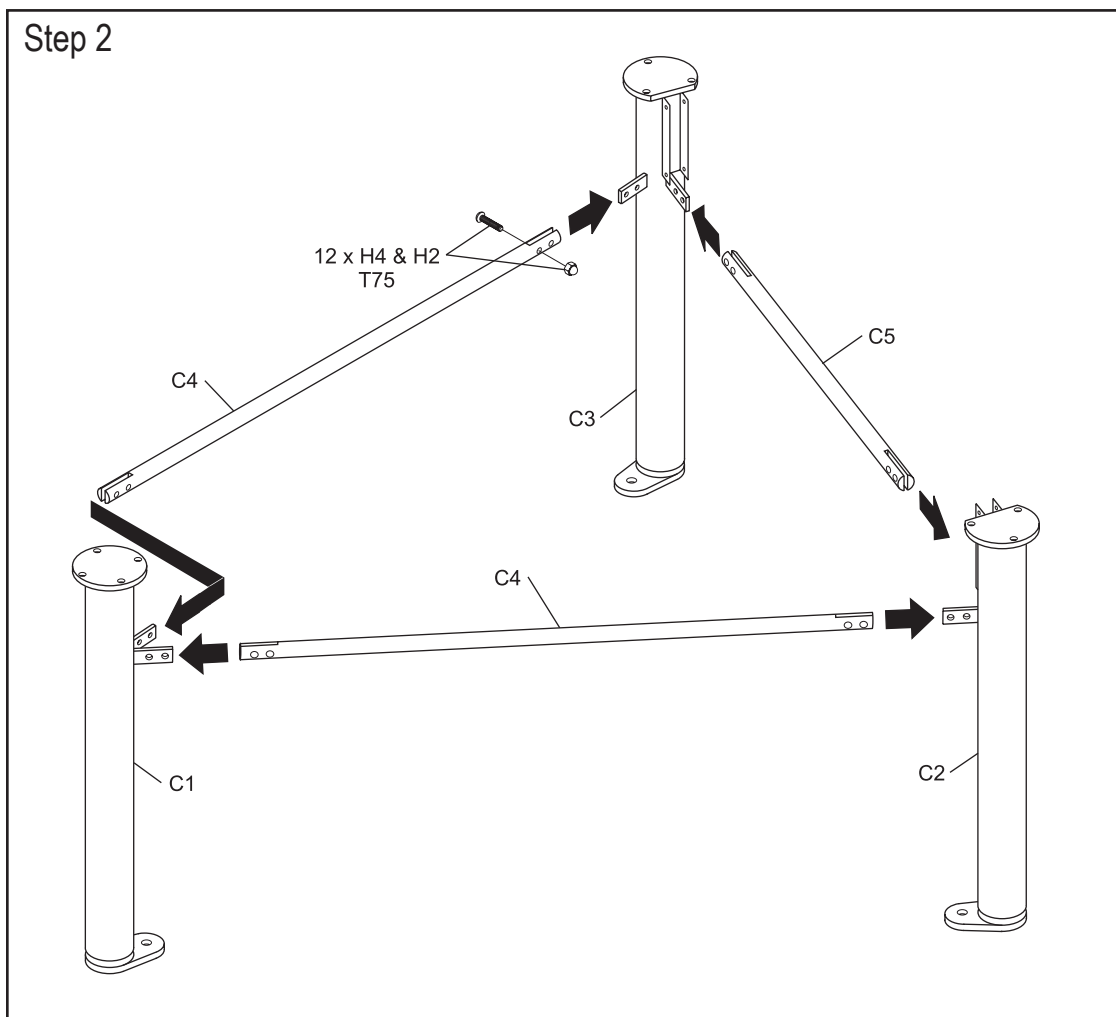
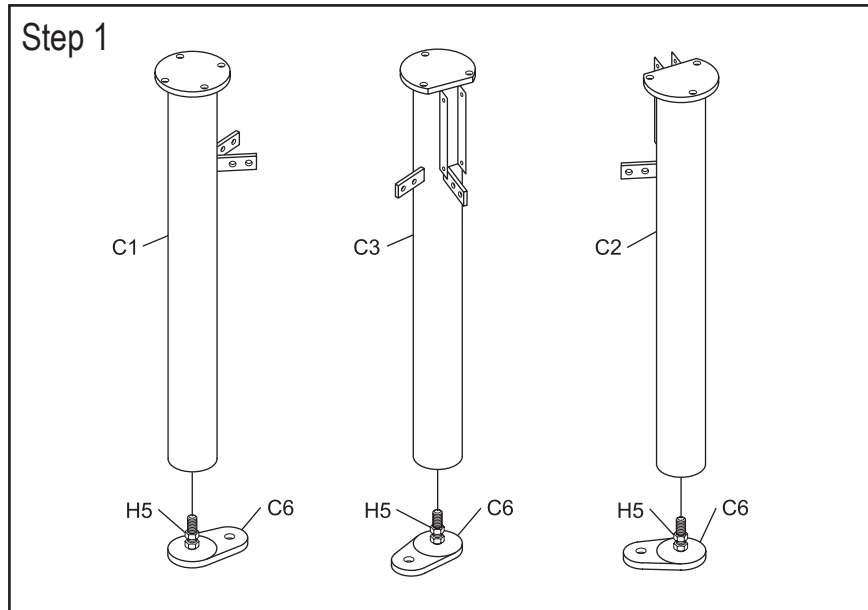

Step 3

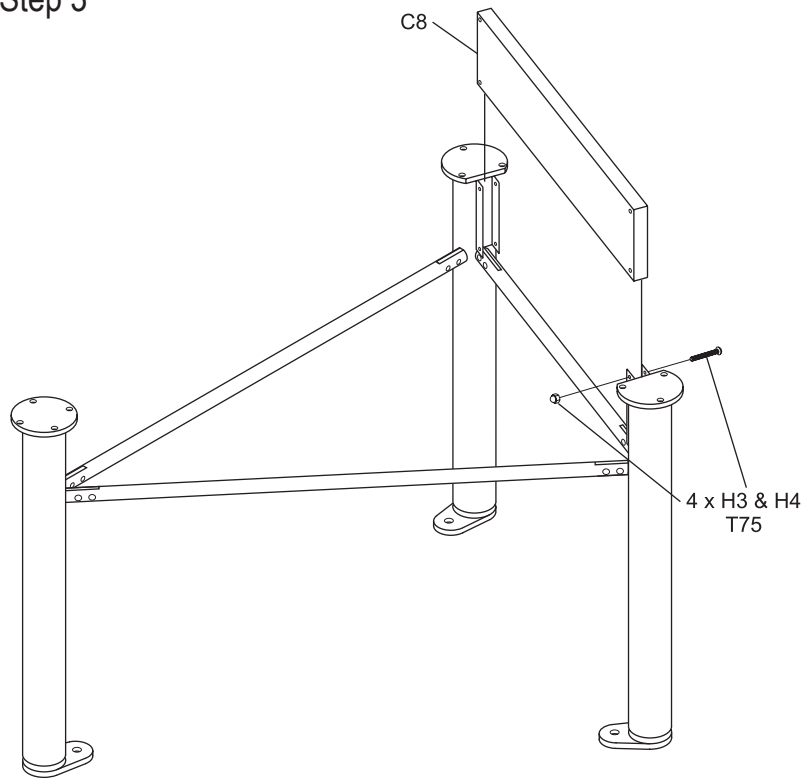

Step 4

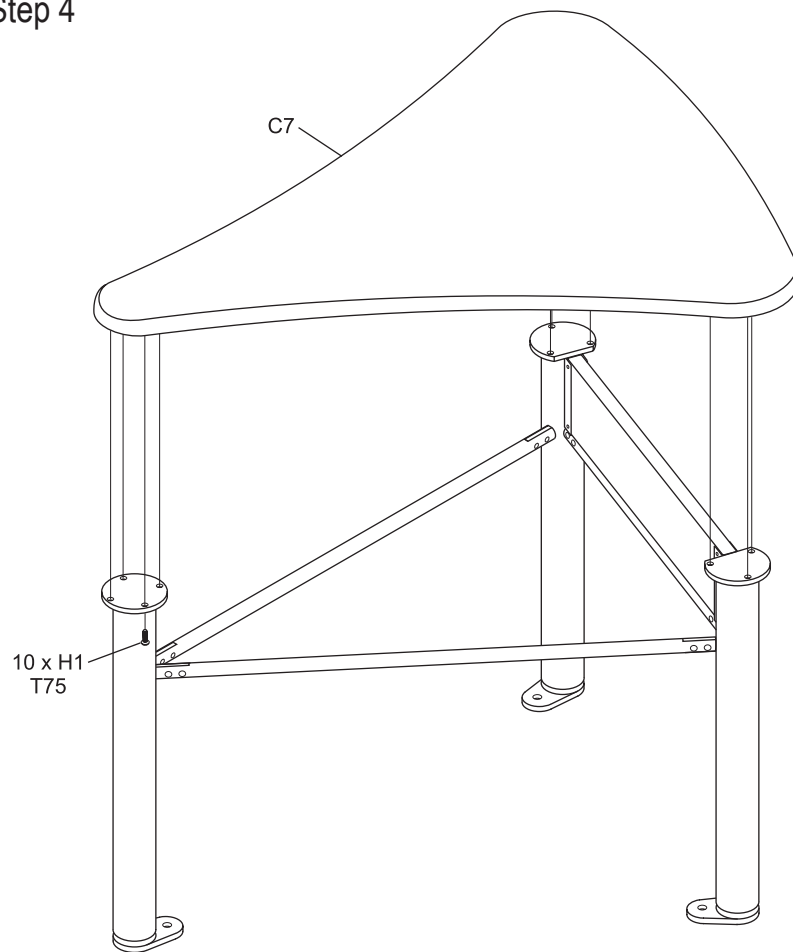

Step 5

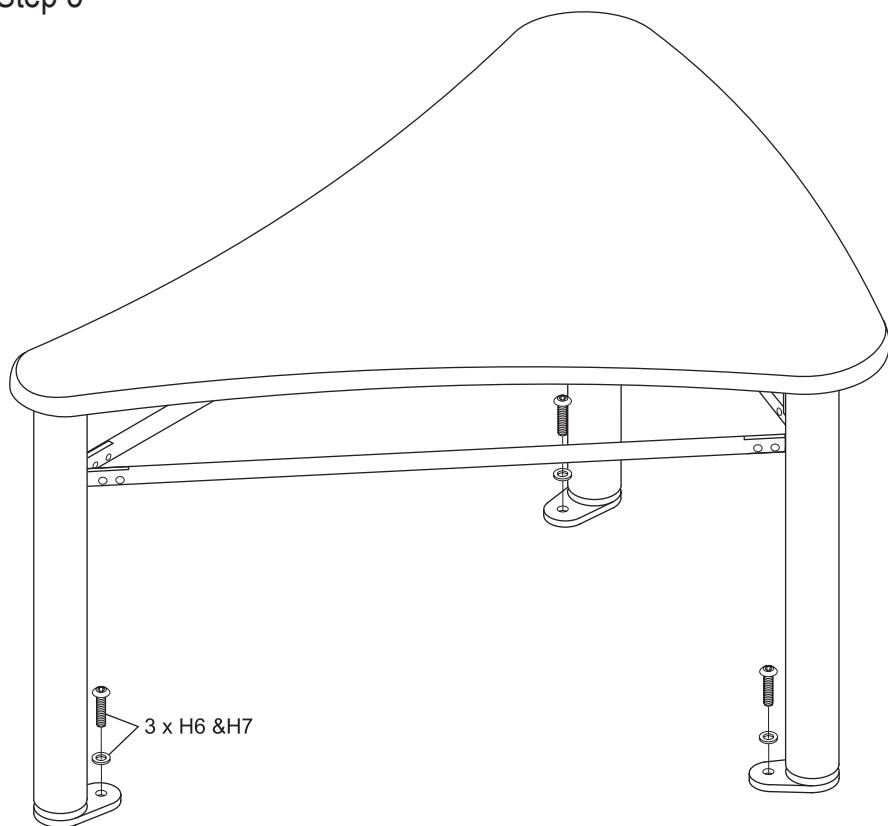

Sofa

Sofa Components

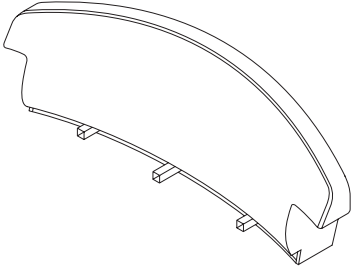
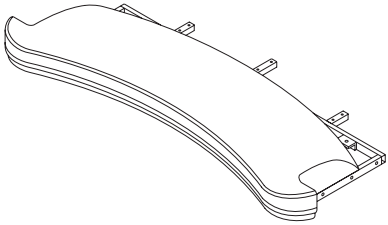
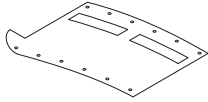
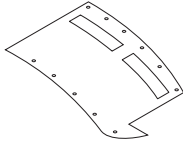
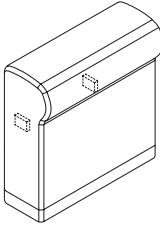
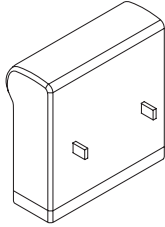
ITEM	PART NUMBER	DESCRIPTION	QTY	ILLUSTRATION
C1	54-861004-XXX	BACK REST	1	
C2	54-861005-XXX	SEAT	1	
C3	54-200008-XXX	LEFT BOTTOM PANEL	1	
C4	54-200009-XXX	RIGHT BOTTOM PANEL	1	
C5	54-861001-XXX	RIGHT ARM REST	1	
C6	54-861003-XXX	LEFT ARM REST	1	

Torque Specifications







ITEM	TORQUE SPEC
T75	75 INCH POUNDS (8.5 NEWTON METRES)
21100	100 INCH POUNDS (11.3 NEWTON METRES)

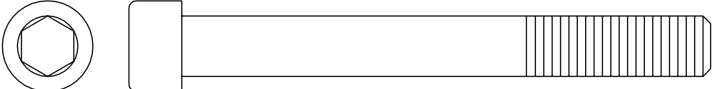
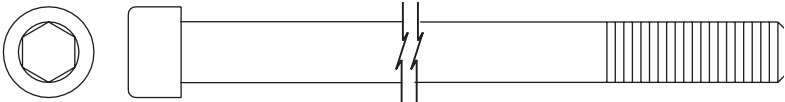

CAUTION!

Over-tightening fasteners can result in product damage.

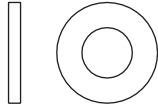
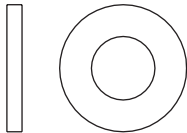
Sofa Hardware

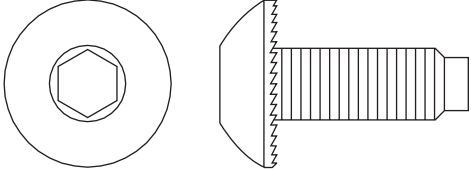
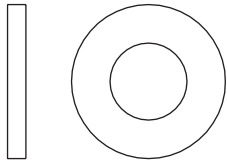
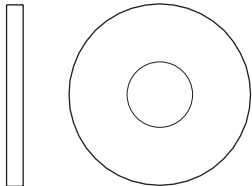
ITEM	PART NUMBER	DESCRIPTION	QTY	ILLUSTRATION
H1	11-051891-000	M4 x 17mm LG FLAT HEAD C.R. WOOD SCREW	24	
H2	11-051509-009	M6 x 1.0 12mm LG SKT HEAD CAP SCREW	4	
H3	11-051566-009	M6 x 1.0 40mm LG SKT HEAD CAP SCREW	12	
H4	11-051567-009	M8 x 1.25 70mm LG SKT HEAD CAP SCREW	6	
H5	11-051576-009	M8 x 1.25 90mm LG SKT HEAD CAP SCREW	2	
H6	11-053786-009	M6 x 1.0 12mm LG PAN HEAD C.R. SCREW	4	
H7	11-052023-001	M6 FLAT WASHER	16	
H8	11-052003-001	M8 FLAT WASHER	8	
H9	54-200010-000	GLIDE	8	
H10	53-400301-002	3/8-16 x 1 LG BTN HEAD SKT CAP SCREW (SPECIAL)	2	
H11	11-191014-009	3/8 FLAT WASHER	2	
H12	11-052019-001	M8 OVERSIZED FLAT WASHER	2	

Sofa Assembly



WARNING!

All Brunswick furniture must be secured properly to the floor before being put into service. Unsecured furniture can tip causing injury!

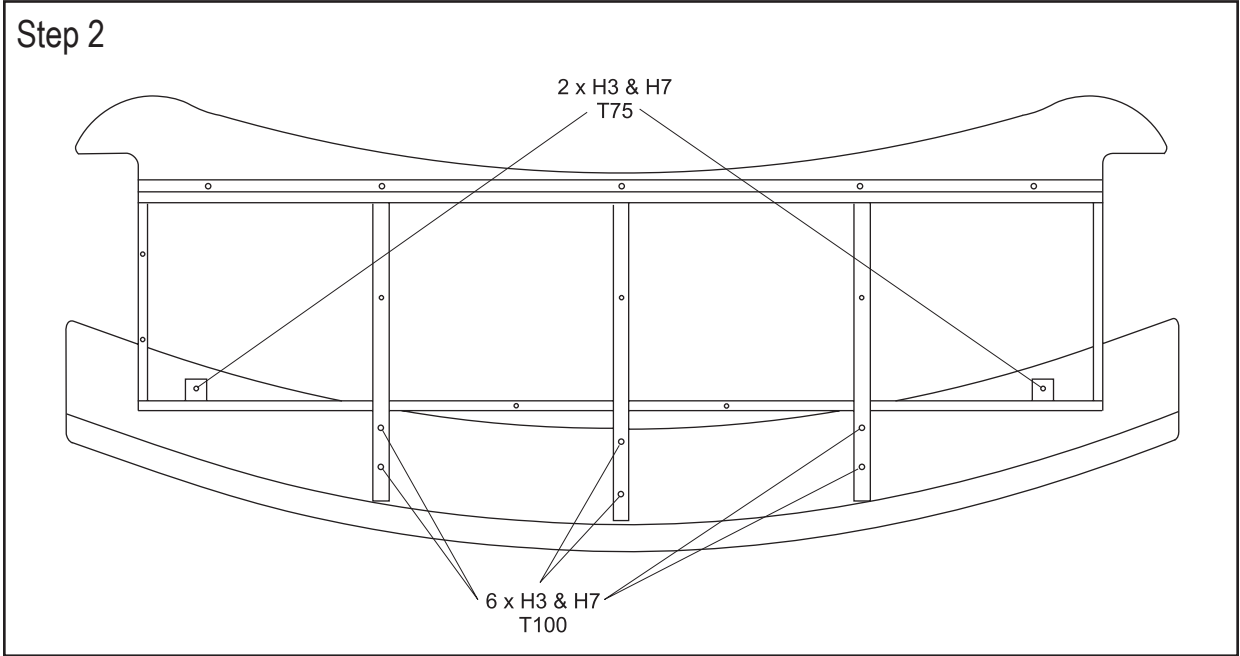
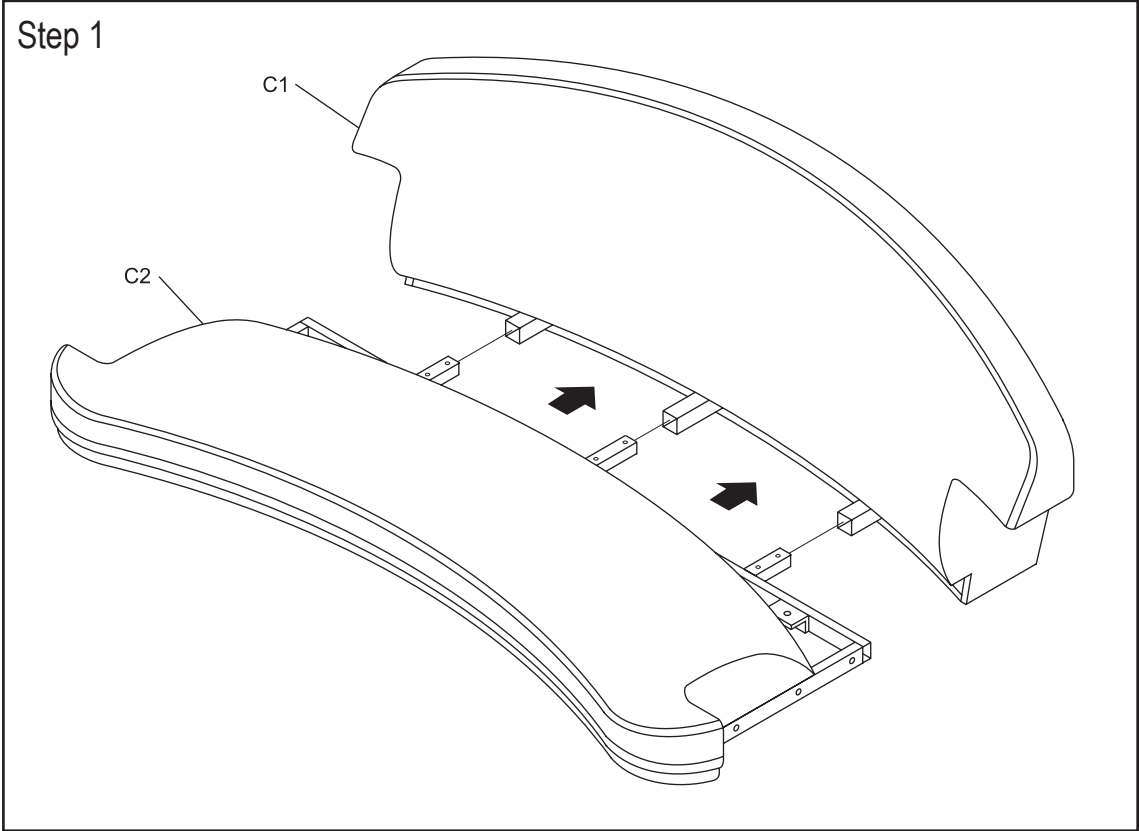

Step 3

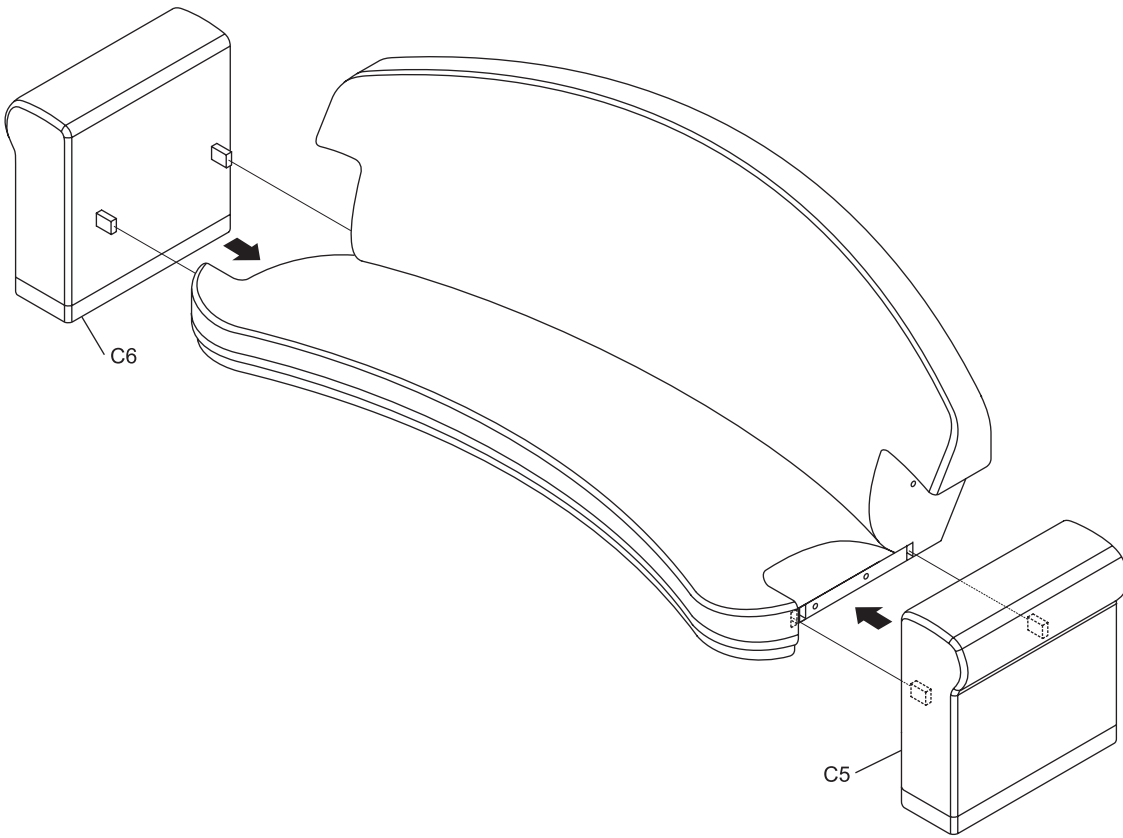

Step 4

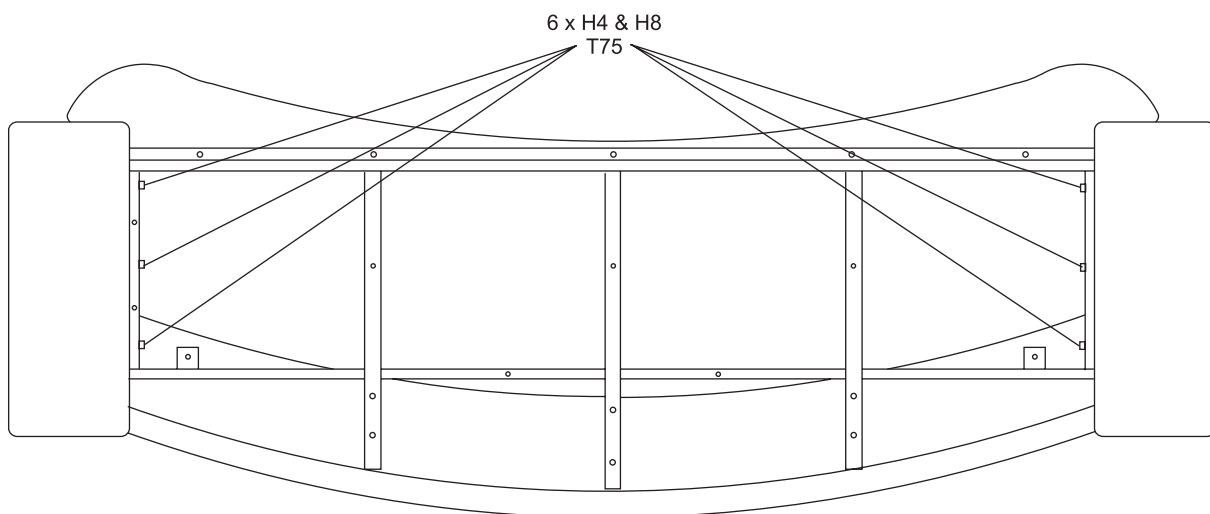

Step 5

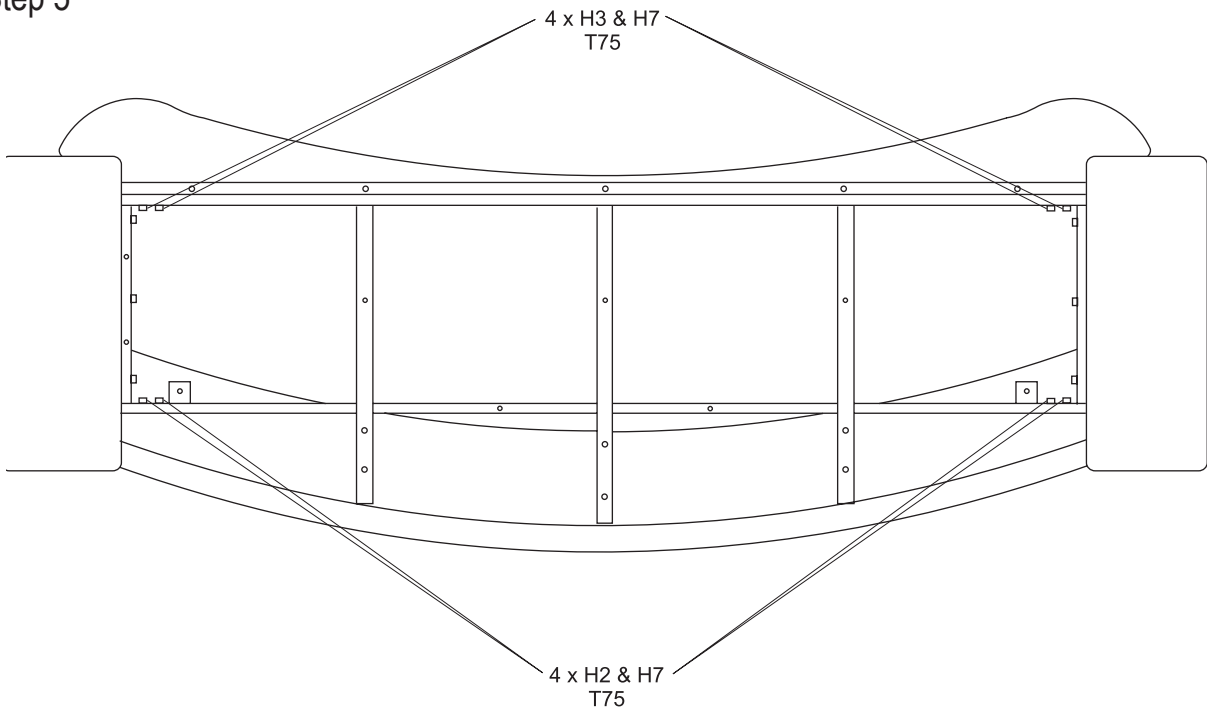

Step 6

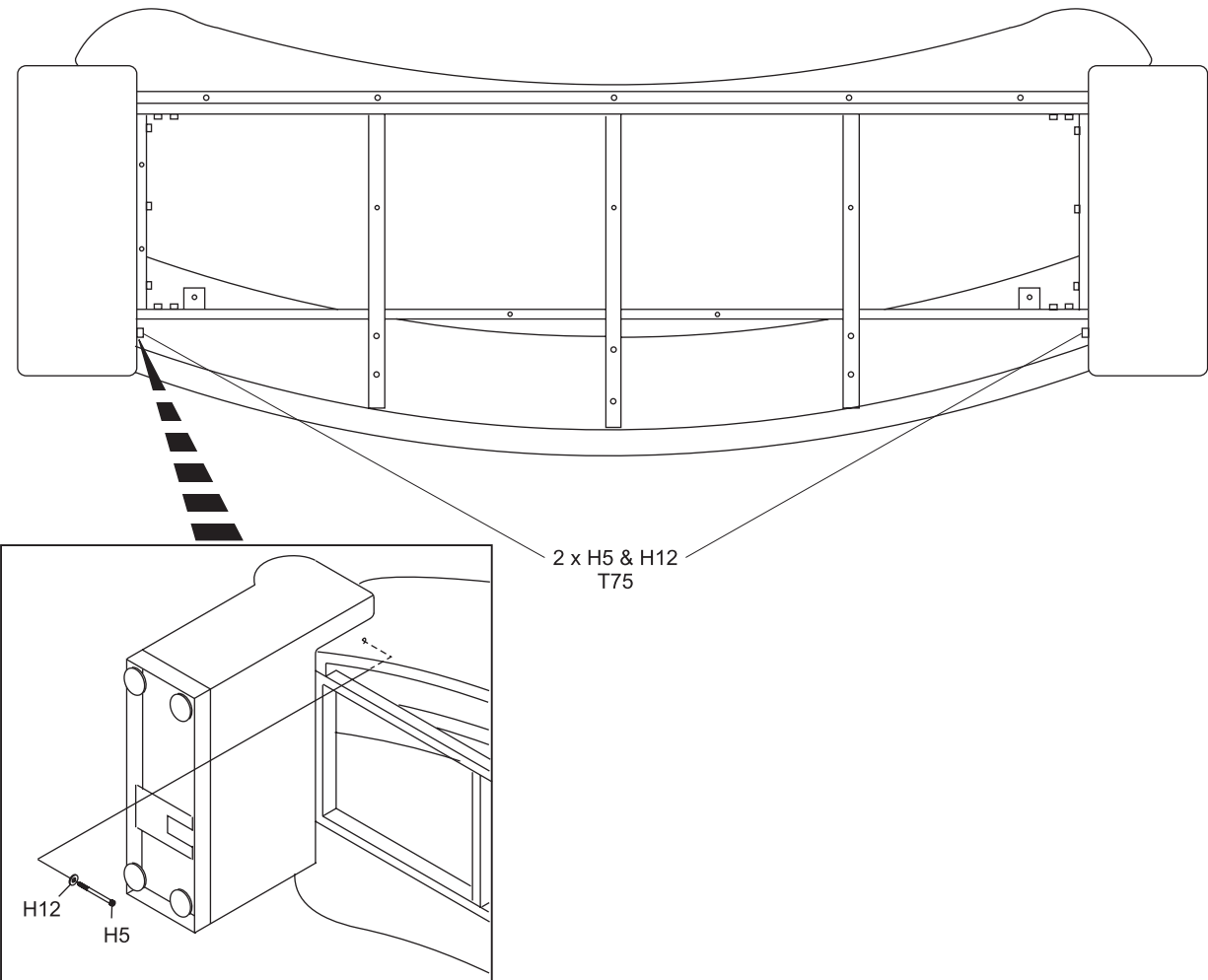

Step 7

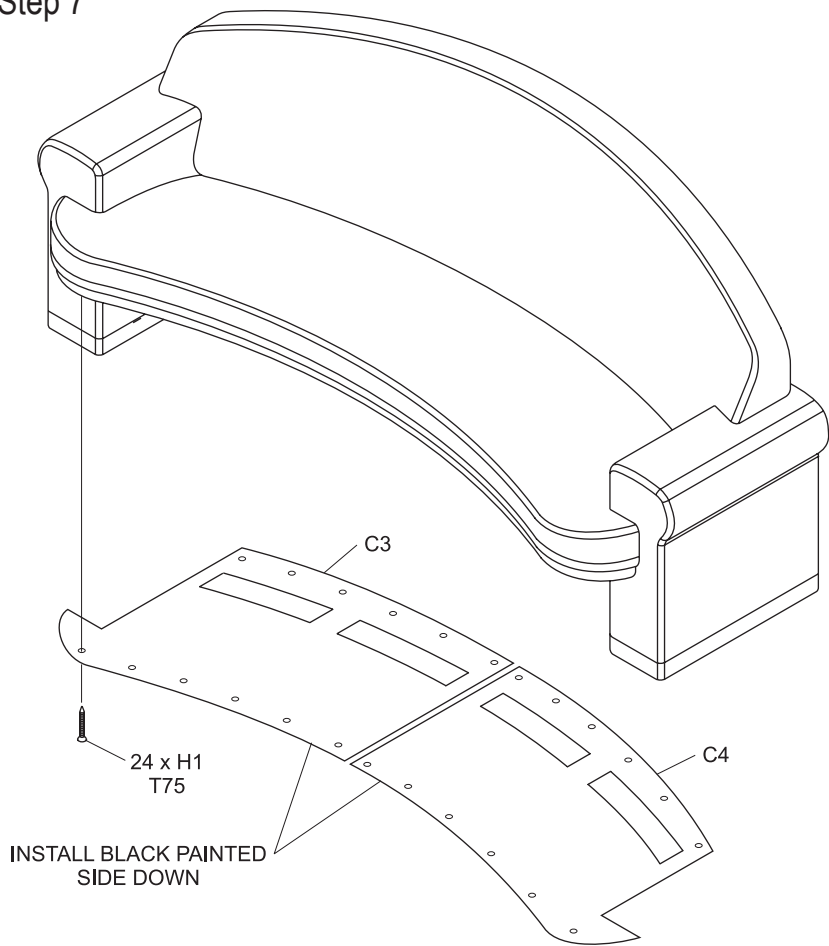



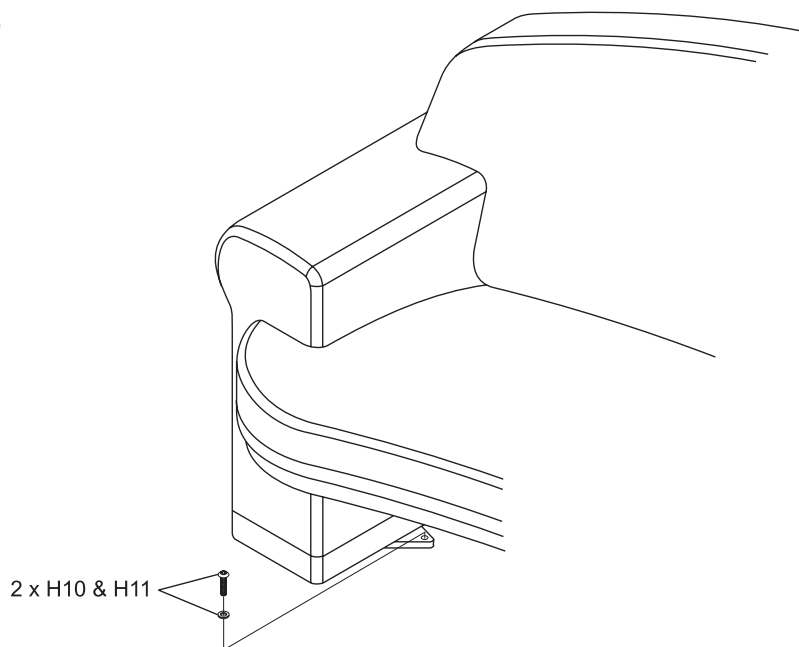

Step 8

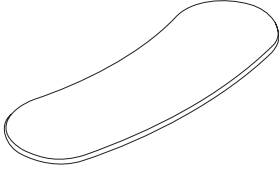
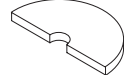

Modwall

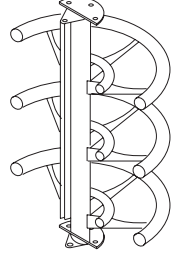
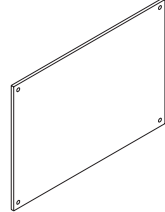
Modwall Components

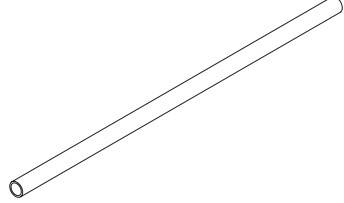
ITEM	PART NUMBER	DESCRIPTION	QTY	ILLUSTRATION
C1	54-861022-XXX	TABLE TOP	1	
C2	54-861025-XXX	FOOT	2	
C3	54-861028-XXX	END VERTICAL PANEL	4	
C4	11-053033-000	COAT HOOK	16	
C5	54-861023-XXX	BALL RACK	2	
C6	54-861027-XXX	CENTER VERTICAL PANEL	1	
C7	54-200034-000	BALL BUMPER	12	
C8	54-200014-000	FOOT REST BRACKET	2	
C9	54-200036-000	FOOT REST RAIL	1	

Modwall Hardware

ITEM	PART NUMBER	DESCRIPTION	QTY	ILLUSTRATION
H1	11-052553-001	M8 x 1.25 30 mm LG FLAT C.R. SCREW	6	
H2	11-054807-004	M6 x 1.0 40mm LG BTN HEAD CAP SCREW	4	
H3	11-055526-004	M6 x 1.0 ACORN NUT	8	
H4	11-054808-004	M6 x 1.0 45mm LG BTN HEAD CAP SCREW	4	
H5	11-054809-004	M8 x 1.25 30 mm LG BTN HEAD CAP SCREW	18	
H6	11-053785-004	M4 x 0.7 10mm LG PAN HEAD C.R. SCREW	32	
H7	11-054810-004	M8 x 1.25 55mm LG PAN HEAD SCREW	24	
H8	53-400301-002	3/8-16 x 1 LG PAN HEAD CAP SCREW	2	
H9	11-191013-001	3/8 FLAT WASHER	2	
H10	11-052812-009	M8 x 10mm SET SCREW	2	

Torque Specifications

ITEM	TORQUE SPEC
T75	75 INCH POUNDS (8.5 NEWTON METRES)
T100	100 INCH POUNDS (11.3 NEWTON METRES)



CAUTION!

Over-tightening fasteners can result in product damage.

Modwall Assembly



WARNING!

All Brunswick furniture must be secured properly to the floor before being put into service. Unsecured furniture can tip causing injury!

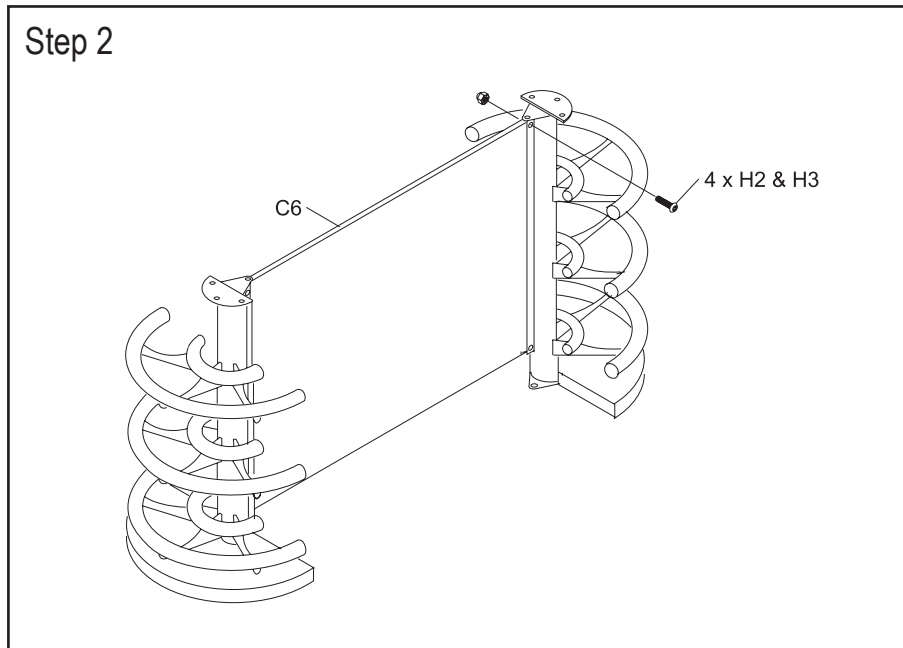
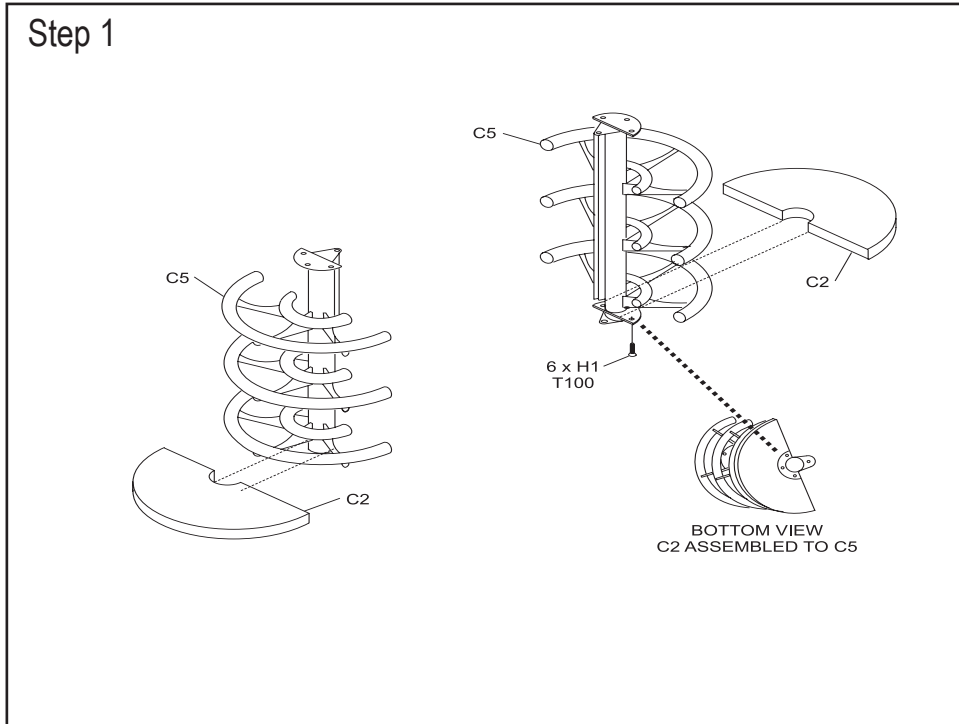

Step 3

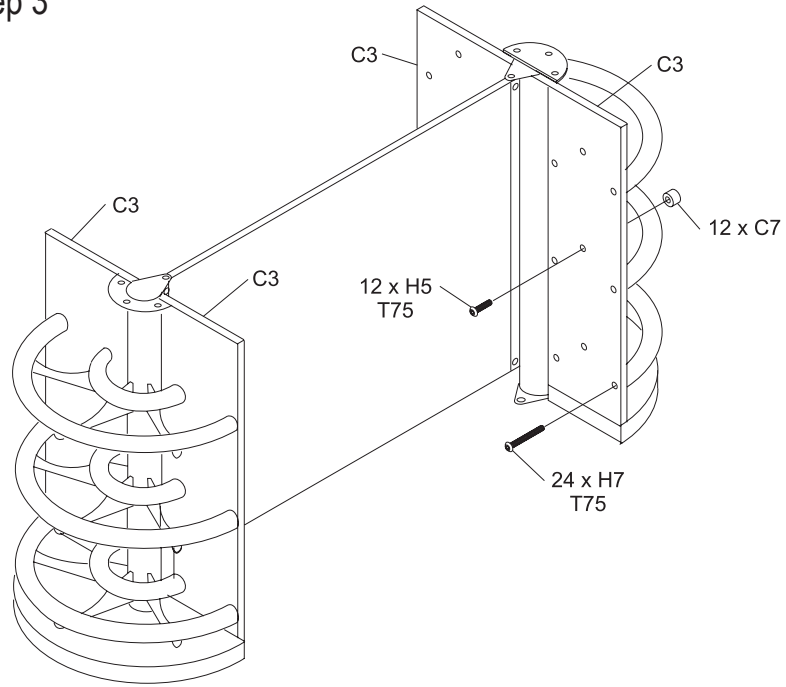

Step 4

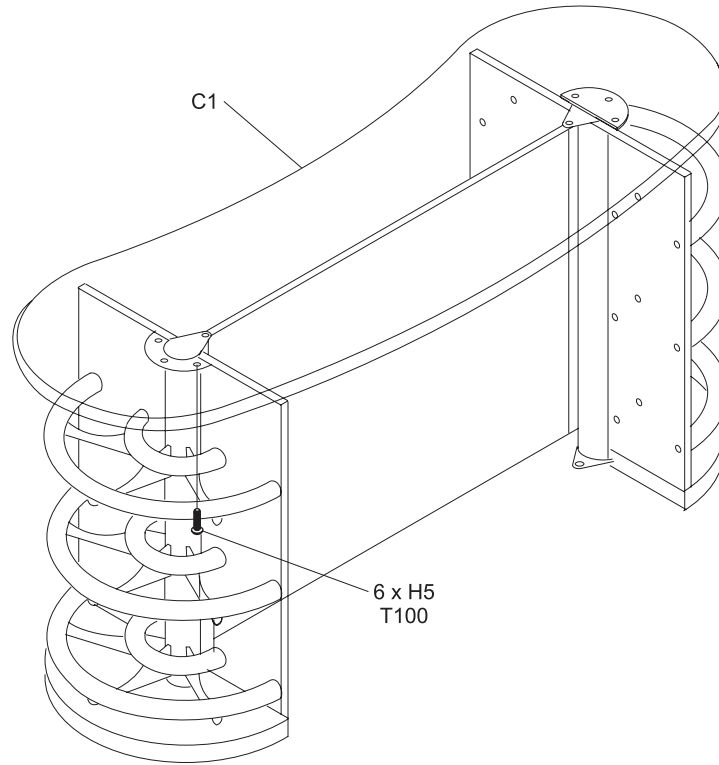

Step 5

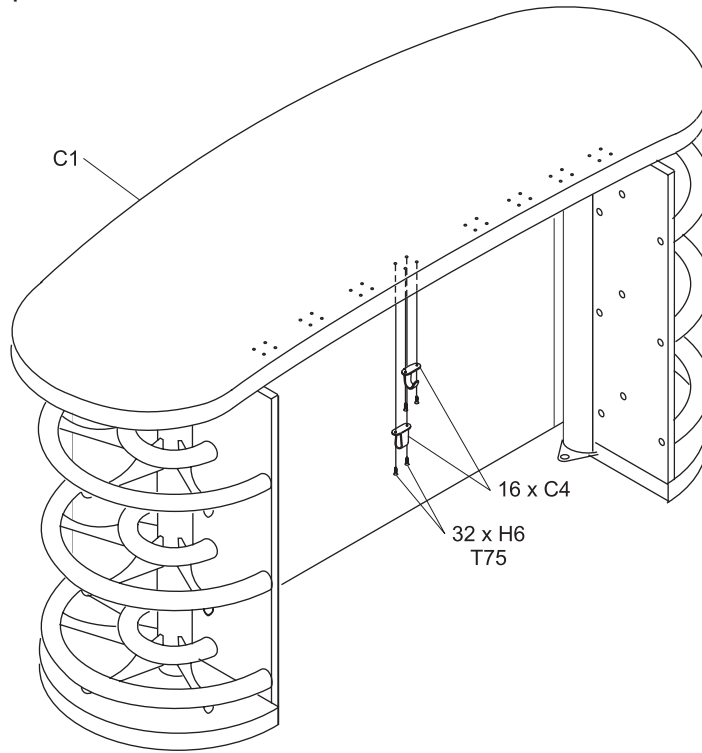

Step 6

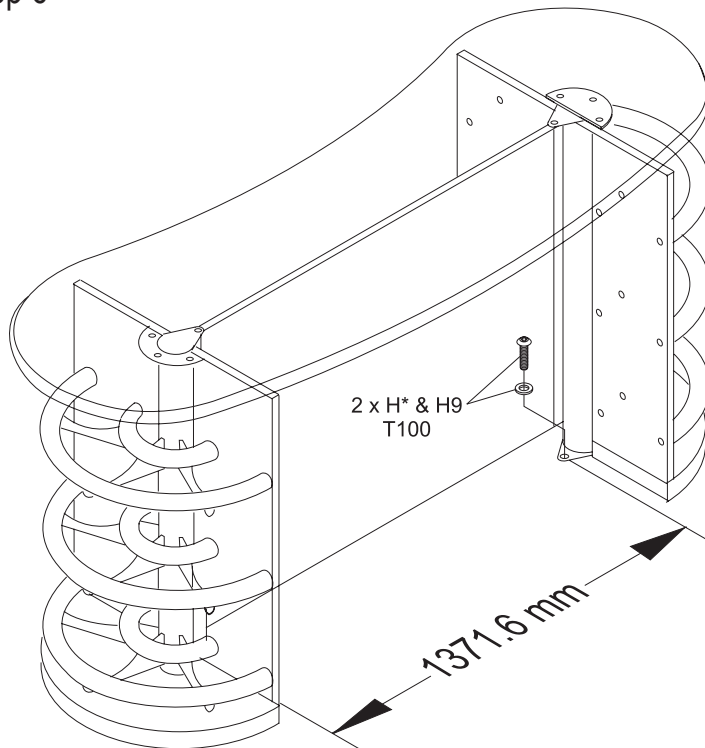

Step 7

i Note: If the Center Vertical Panel is not pre-drilled for the Foot Rest mounting holes, it will be necessary to drill these per the following illustration.

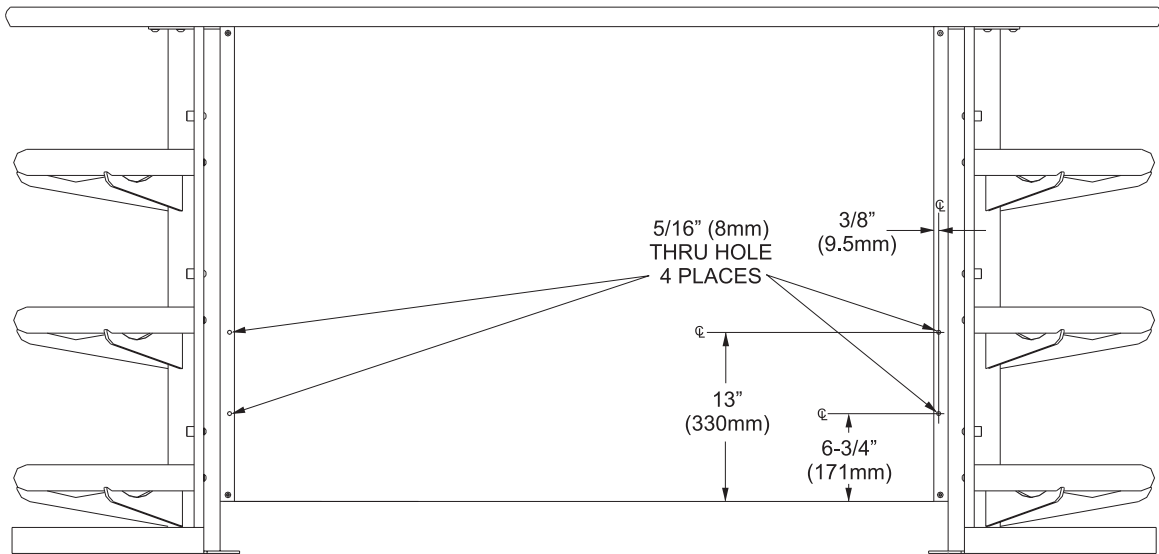

Step 8

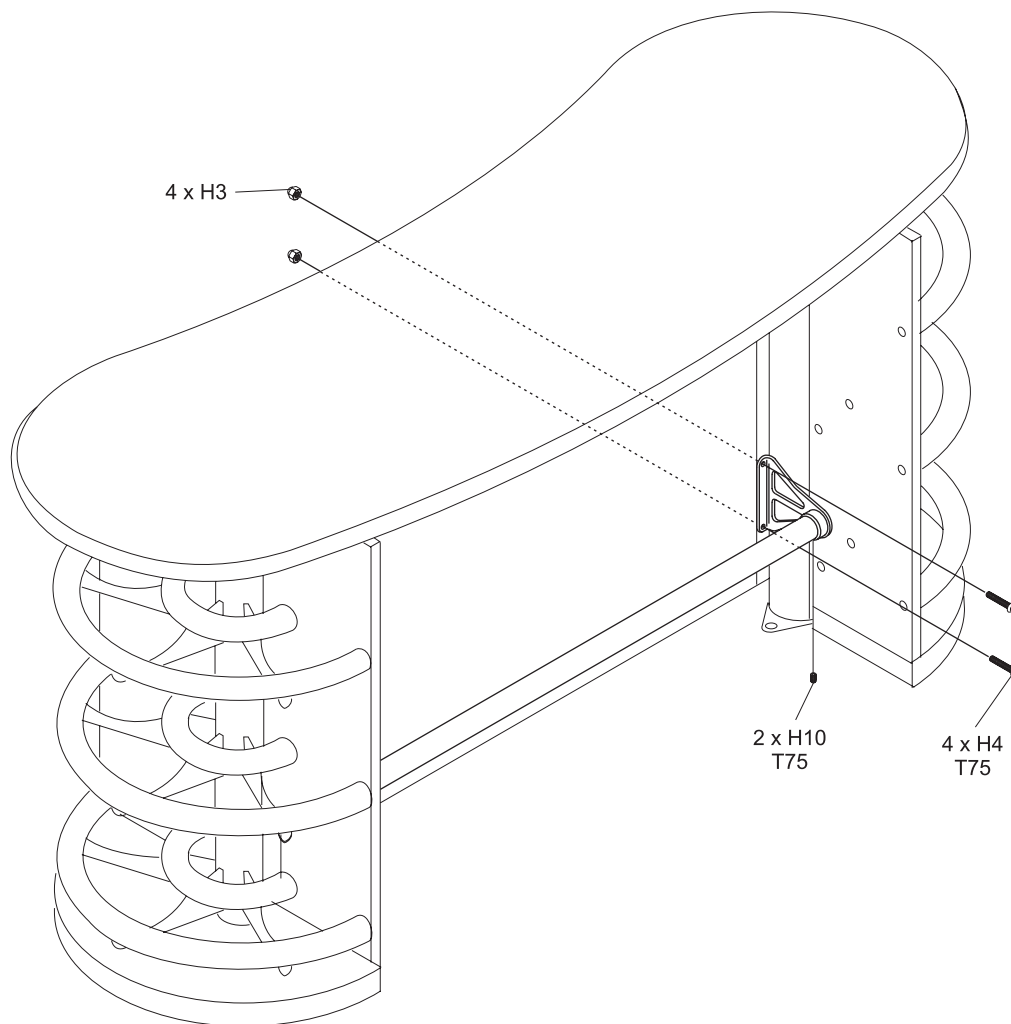

Optional Modwall Swing/Swivel Seats

Swing/Swivel Seat Components

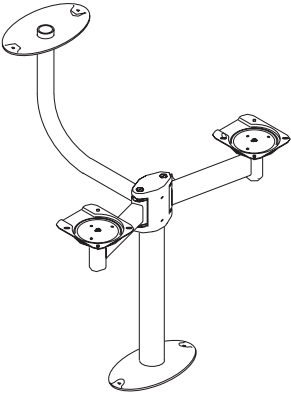
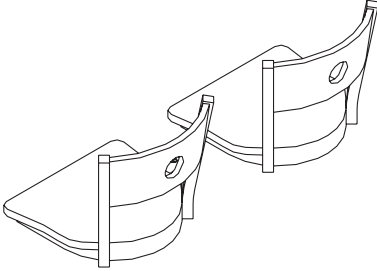
ITEM	PART NUMBER	DESCRIPTION	QTY	ILLUSTRATION
C1	54-861049-001	SWING SWIVEL ASSEMBLY	1	
C2	54-861040-XXX OR 54-861042-XXX OR 54-861044-XXX OR 54-861046-XXX OR 54-861048-XXX	BAR STOOL - FLORENCE BUCKET ONLY (2 EACH) BAR STOOL - CONTESSA BUCKET ONLY (2 EACH) BAR STOOL - CATALINA BUCKET ONLY (2 EACH) BAR STOOL - VOLTAIRE 830B BUCKET ONLY (2 EACH) BAR STOOL - VOLTAIRE 330D BUCKET ONLY (2 EACH)	1	

Swing/Swivel Seat Hardware

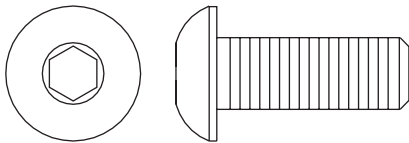
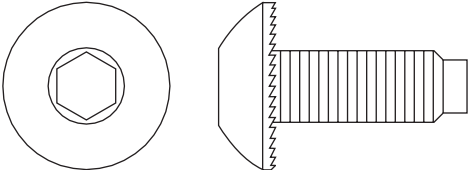
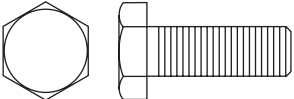
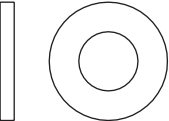
ITEM	PART NUMBER	DESCRIPTION	QTY	ILLUSTRATION
H1	11-006345-000	3/8-16 x 1 LG BTN HEAD CAP SCREW	2	
H2	54-400301-002	3/8-16 x 1 LG BTN HEAD CAP SCREW (SPECIAL)	2	
H3	11-002002-013	1/4-20 x 3/4 LG HEX HEAD CAP SCREW W/ LOCKTITE	8	
H4	11-191010-001	1/4 PLAIN WASHER	8	

Torque Specifications

ITEM	TORQUE SPEC
T75	75 INCH POUNDS (8.5 NEWTON METRES)
T100	100 INCH POUNDS (11.3 NEWTON METRES)



CAUTION!

Over-tightening fasteners can result in product damage.

Swing/Swivel Seat Assembly



WARNING!

All Brunswick furniture must be secured properly to the floor before being put into service. Unsecured furniture can tip causing injury!

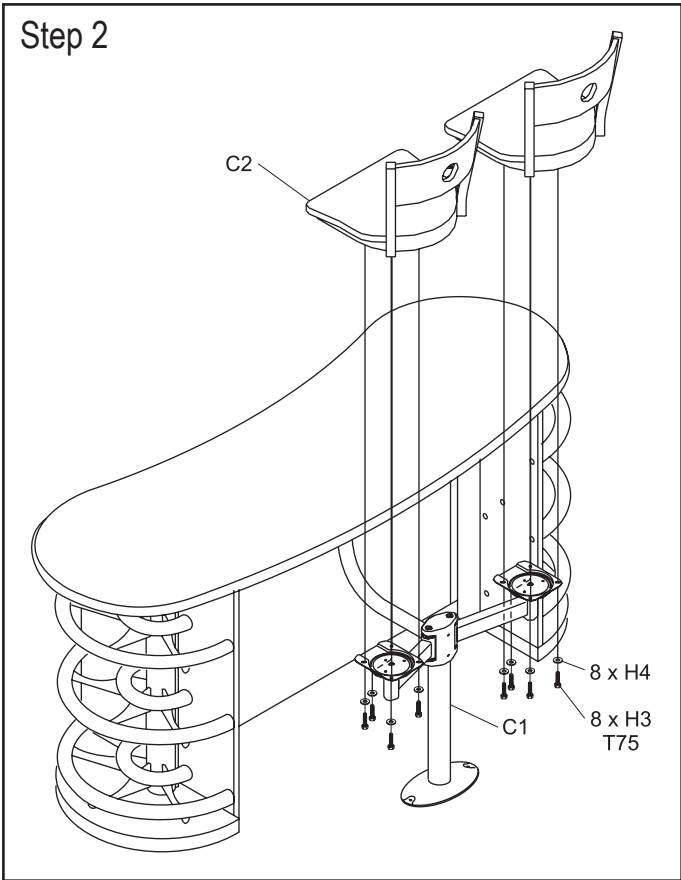
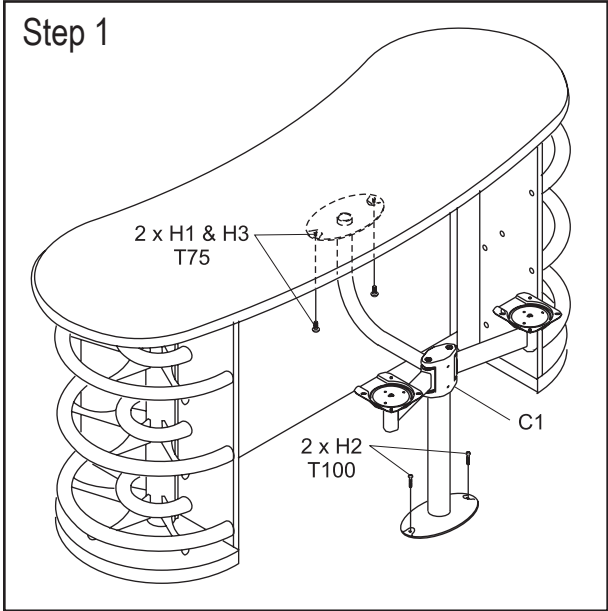

Specifications

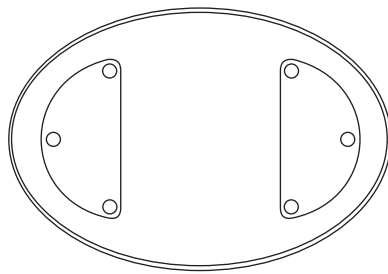
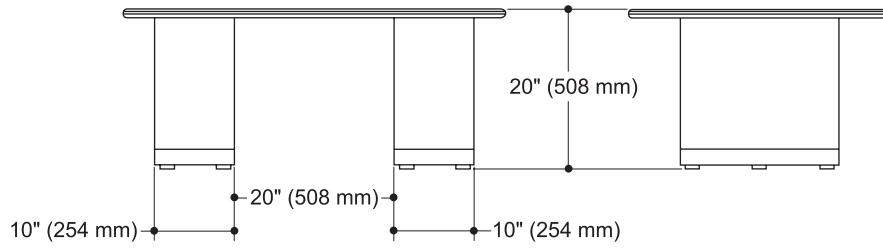
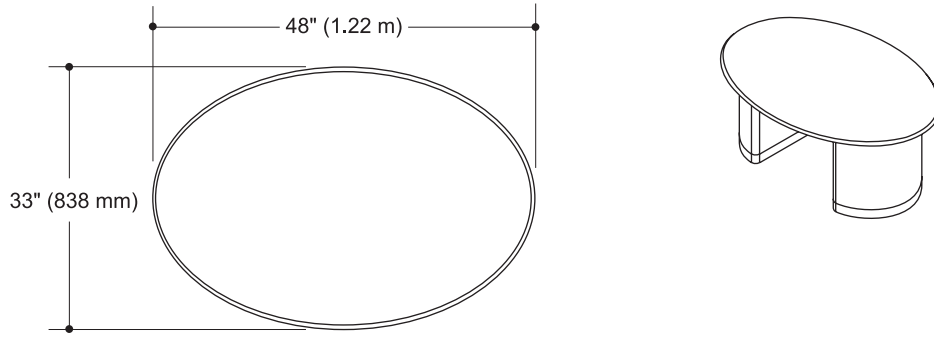

COFFEE TABLE
Weight: 75 lb. (34.0 kg)

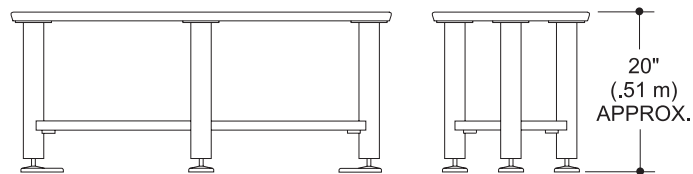
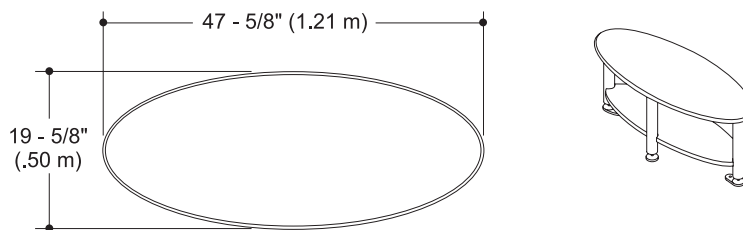

NARROW COFFEE TABLE
Weight: 75 lb. (34 kg)

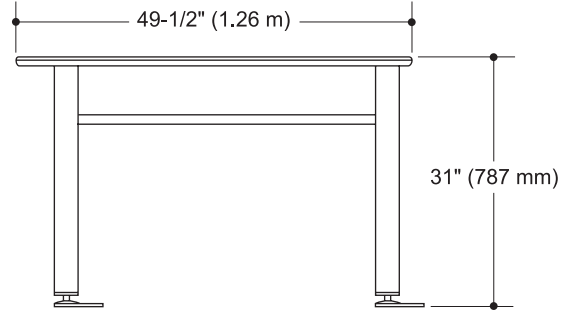
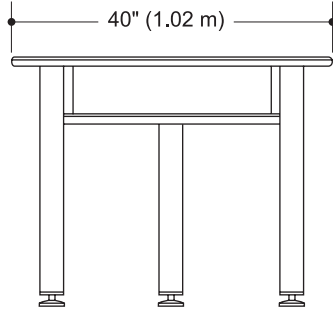
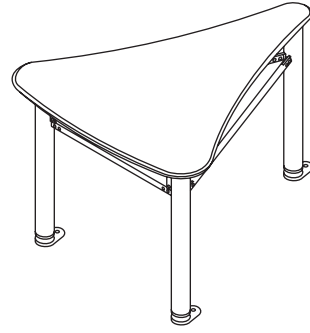
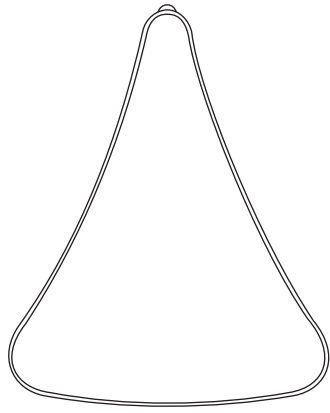

SOFA TABLE
Weight: 95 lb. (43.1 kg)

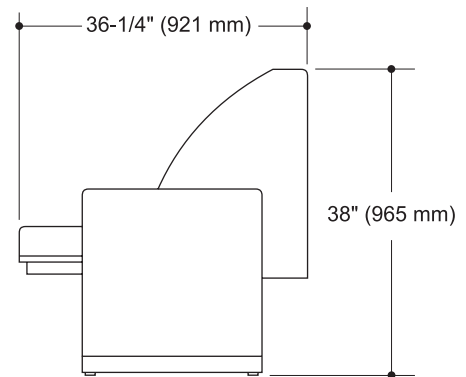
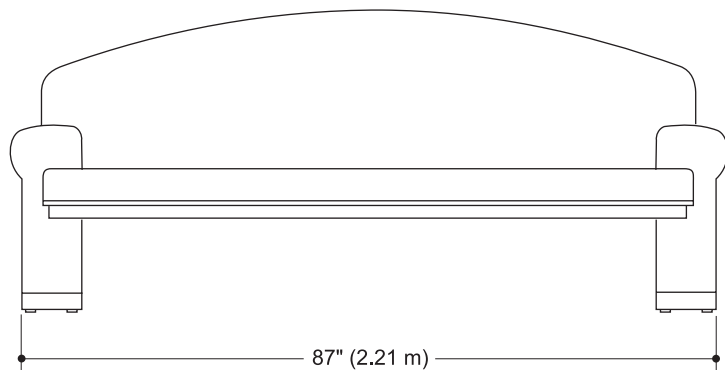
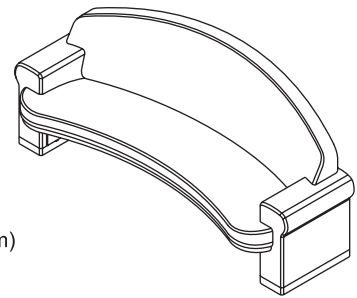
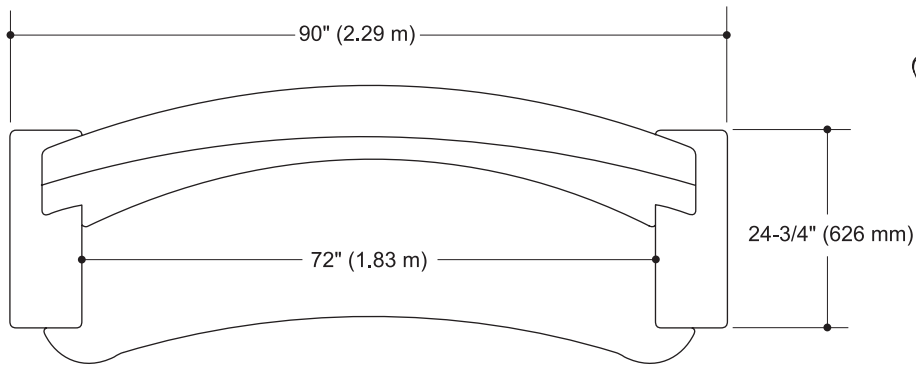

SOFA
Weight: 335 lb. (152.0 kg)

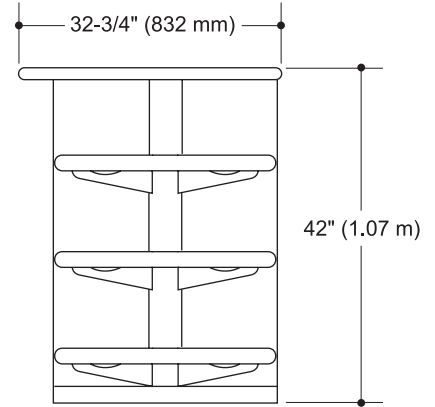
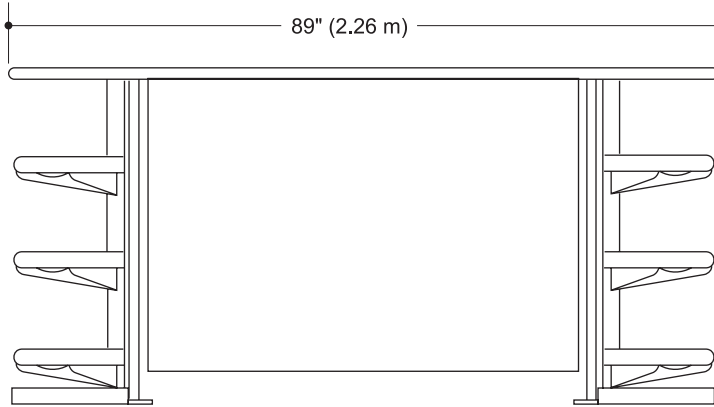
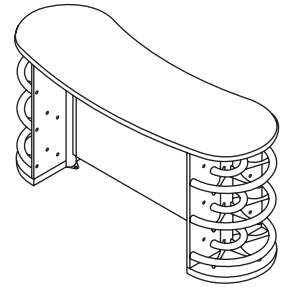
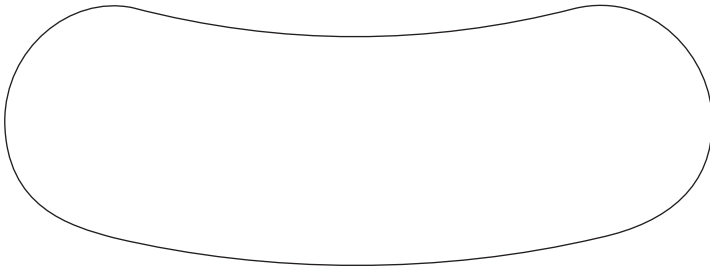

MODWALL
Weight: 400 lb. (181.4 kg)

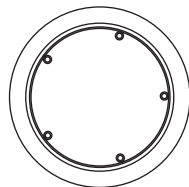
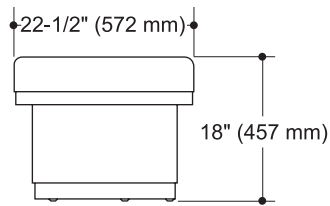

OTTOMAN
Weight: 30 lb. (13.6 kg)

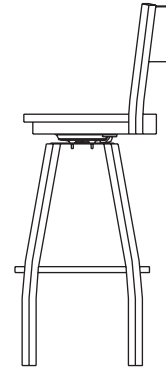
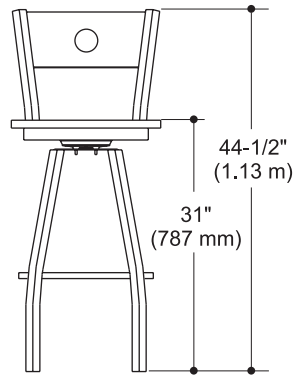
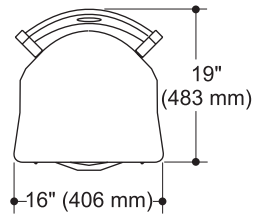

FREE STANDING BAR HEIGHT CHAIR
Weight: 15 lb. (6.8 kg)