

## Poly-Tite Compression Fitting

### Packaging

- 1 ea. 14-860034-000 Compression Fitting Kit
- 1 ea. 11-655079-091 Fitting with Teflon Tape
- 1 ea. 14-900055-000 Instruction Sheet

### Tools Required

- Wrench - 11/16"
- Wrench - 7/16"

### Installation Procedure

1. Remove the old inlet fitting from the conditioner filter assembly (14-100481-000).
2. Clean any old thread sealant from the threads of the conditioner filter inlet if necessary.
3. The new Poly-Tite compression fitting comes pre-assembled with thread sealing tape (11-900080-000). Verify that this thread sealing tape does not extend over the first thread.
4. Install the 3/8" NPT into the conditioner filter inlet until it is hand tight.
5. Using an 11/16" wrench, tighten the fitting 2 -1/4 +/- 1/4 turns.
6. Remove the 7/16" compression nut.
7. Make sure that the tubing is cut squarely within a maximum of 15 degrees. It is recommended that old tube be replaced with new.
8. Thread the tube through the black plastic seal and onto the brass nipple until it bottoms out. Refer to Figure 1.
9. Assemble the 7/16" compression nut onto the fitting and hand tighten.
10. Using a 7/16" wrench, tighten the compression nut one full turn.

**i** **NOTE:** Poly-Tite compression fittings can be assembled and disassembled repeatedly.

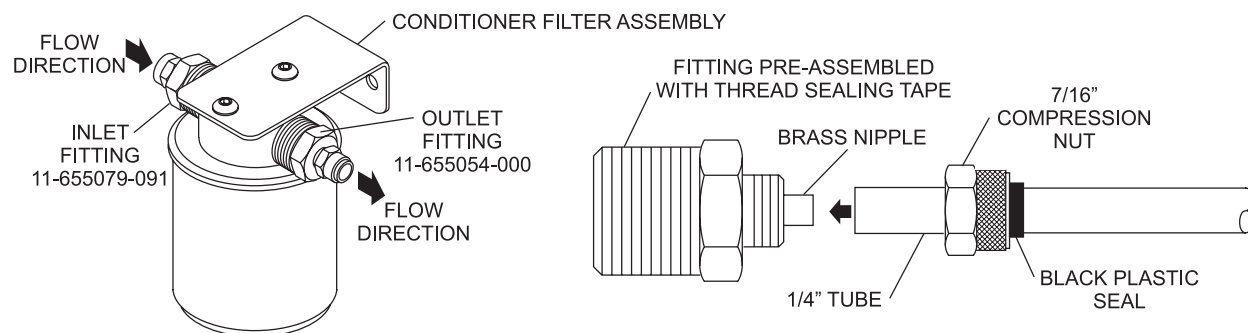

Figure 1