

A-2 Japanese Electrical Box Cover

12-862948-000

Packaging

- (1) 12-862948-000 A-2 Japanese Electrical Box Cover Package
 - (1) 12-750872-000 A-2 Japanese Electrical Box Cover Assembly
 - (1) Japanese Electrical Box Cover
 - (4) #10-32 x 3/8" Phillip Screws
 - (4) Hex Nuts
 - (1) Safety Decal
 - (1) 12-902076-000 Instruction Sheet

Installation Instructions

1. Cycle the pinsetter to 270 degrees.



WARNING! Remove power to the pinsetter by turning off the circuit breaker and unplugging the main power cord to the electrical box.

2. To improve the ease of installation it is suggested that all fastening hardware mounting the Electrical Box Assembly to the pinsetter frame be loosened. On the Channel Support Assembly, loosen mounting bolt (P/N 11-001263-001) to allow for slight movement of the channel.



NOTE: Do not completely remove the hardware securing the Channel Support Assembly.

3. On the Electrical Box Assembly, loosen mounting bolt (P/N 11-001260-001) on the bottom of the box, and U-bolt (P/N 12-750007-000) on the back of the box.



NOTE: Do not completely remove the hardware securing the Electrical Box Assembly.

4. Open the new Japanese Electrical Box Cover package (P/N 12-862948-000) and unhinge the access panel by sliding it to the left. Set the access panel aside for now. Refer to *Figure 1*.

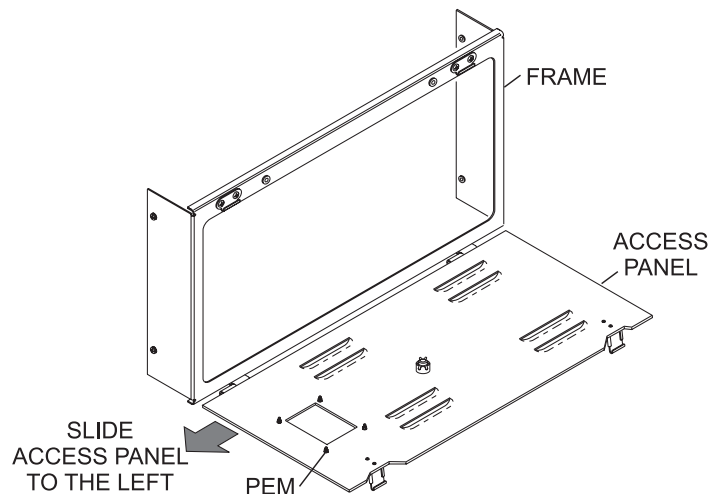

Figure 1

5. Mount the frame over the open Electrical Box Assembly. Position the sides of the frame inside of the Electrical Box Assembly, aligning the threaded inserts to match the existing mounting holes for the original cover. The upper and lower lip of the frame will cover the top and bottom edge of the Electrical Box.

i **NOTE:** Electrical box assemblies may be bent or damaged. Make sure the existing box provides enough clearance for secure frame installation.

6. Once the frame is in place, secure it with the hardware provided.
7. On the front of the access panel, adhere the provided safety decal between the main circuit breaker opening and motor overload relay opening. Refer to *Figure 2*.

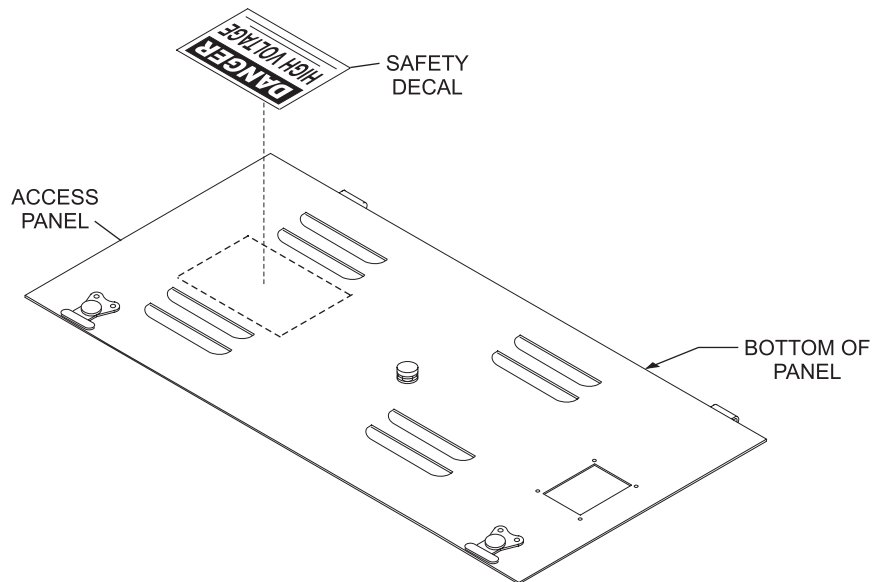

Figure 2

8. For electrical boxes with circuit breaker, 12-860627-000, and the filler plate, remove the plate from the existing electrical cover. Using the Pem® fasteners on the inside of the access panel and the provided nuts, fasten the plate to the access panel. For boxes without the filler plate, secure the provided nuts to cover the Pem® fasteners.
9. Slide the access panel back into the hinges. Carefully close and latch at the top of the panel making sure not to pinch wires. The Electrical Box is now completely covered.
10. Depending upon what the circuit breaker, motor contactor and thermal overload combinations are in the Electrical Box, further work may be needed to the access panel to provide proper clearance for these parts.
11. Re-tighten the bolts on the Channel Support Assembly and Electrical Box Assembly.
12. Before power is restored to the Electrical Box carefully double check that there are no wires in a position to be pinched by the new Electrical Box Cover. Reconnect power to the pinsetter.