

## Spinning Ball Eliminator II 12-862250-000

The Brunswick Spinning Ball Eliminator II is a device designed to fit over the arm assembly of the original Spinning Ball Eliminators currently installed on A/A2 Automatic Pinsetters. Its purpose is to guide a ball into the ball wheel and stop a ball from spinning as it attempts to enter the ball lift rod assembly in a more positive manor then the original Spinning Ball Eliminator. Unlike the rubber arm cover, the urethane wheels rotate as the ball enters onto the ball wheel reducing wear and the subsequent compensating height adjustments of the arm.

### Installation



**WARNING! Disconnect the input power connector to the electrical box.**

1. Remove the rubber cover from the arm of the original Spinning Ball Eliminator installed on the pinsetter. Remove any rubber residue and glue on the arm. Also verify the original spinning ball eliminator is mounted in correct location on the elevator frame. Refer to *Figure 1*.

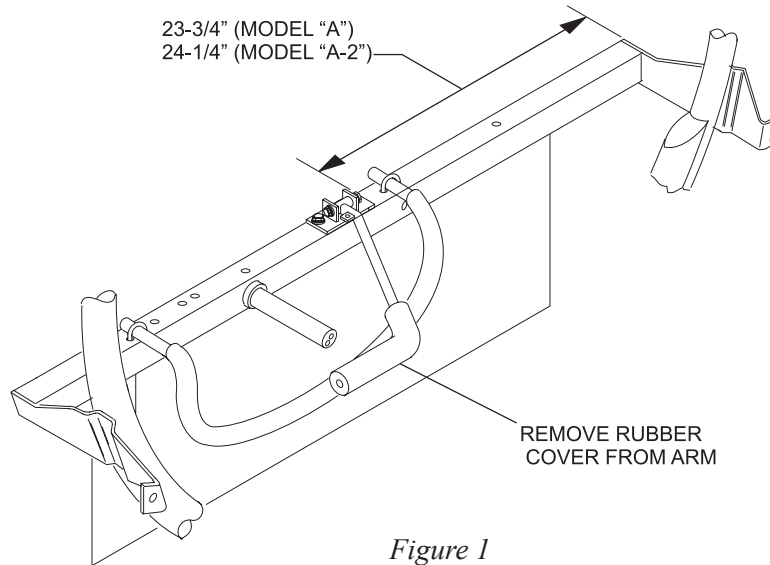

*Figure 1*

2. Check the original Spinning Ball Eliminator for any excessive play in the arm. If there is excessive play, it may be necessary to replace the pivot spacer (12-860583-002). Refer to *Figure 2*

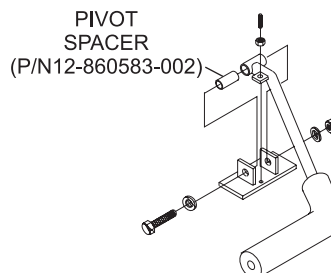

*Figure 2*

3. Slip the SBE II over the end of the arm until it bottoms at the 90 degree bend. Using a 5/32" Allen wrench, tighten the setscrew in the collar closest to the 90 degree bend. Tighten the outer collar leaving a slight gap between the 2 flanged bronze bushings. This will allow the wheels to act independent of one another. Refer to *Figure 3*.

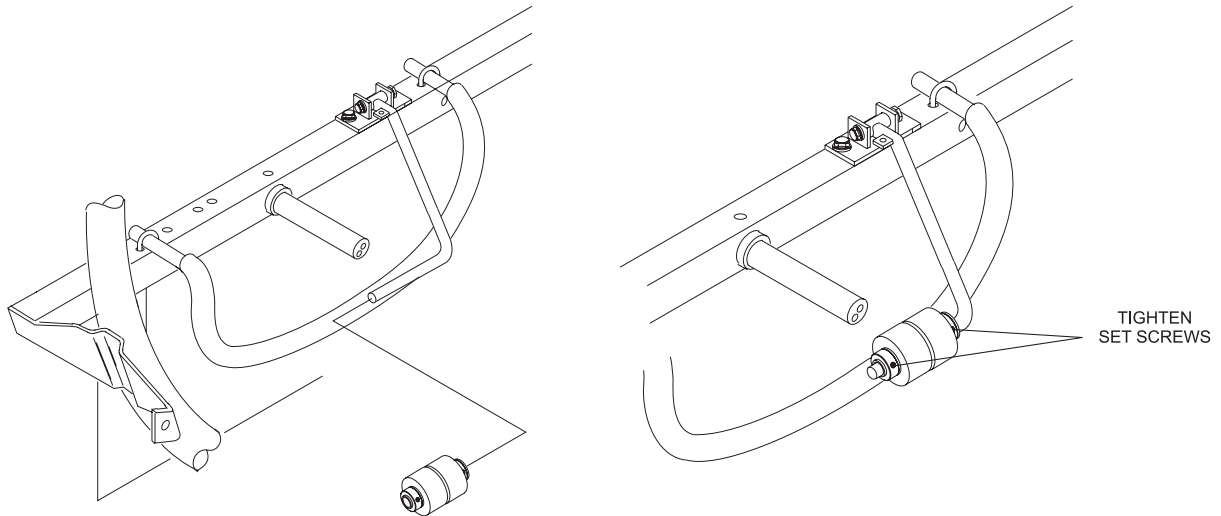

*Figure 3*

## Adjustment

The SBE II should be adjusted so that the minimum contact necessary stops the spin of a ball entering the ball lift rod assembly. If the arm is adjusted too low, it will not function to its optimum capacity. When the arm is in the proper position to stop the spin of the ball, there will only be a slight movement of the arm (no excessive bouncing) when it contacts the spinning ball.

1. Place a standard size bowling ball in the approximate position that ball spinning occurs on your particular pinsetter.
2. On the arm assembly, loosen the jam nut on the 5/16"-18X1 1/2" adjustment screw. Adjust the arm up or down by turning the adjustment screw clockwise or counter-clockwise until minimum contact occurs between the ball and the urethane rollers on the arm assembly.
3. Loosen the hardware mounting the Spinning Ball Eliminator to the elevator frame and position the assembly so the arm assembly and urethane rollers are parallel to the ball wheel.
4. Tighten the jam nut on the adjustment screw and secure the mounting hardware.

**i** **NOTE:** Lubricate the flanged bronze bushing with a drop of oil annually or as required.