

GS Accelerator Protective Cover 47-862787-000

Packaging

- 1 ea. 47-862787-000 Package Protective Cover (4 Pieces)
- 4 ea. 47-034730-009 Plastic Tube

i **NOTE:** It is recommended that plastic tube be installed using compressed air (90 PSI maximum).



CAUTION! Do not over inflate plastic tube as it could burst causing injury.



CAUTION! Always wear safety glasses during this procedure.

Tools Required

- Deluxe Rod Cover Installation Tool, part number 38-4049
- Safety Glasses
- Utility Knife
- Standard Screw Driver

Installation

1. Remove ball rods from accelerator frame and secure in vice. Refer to *Figure 1*.

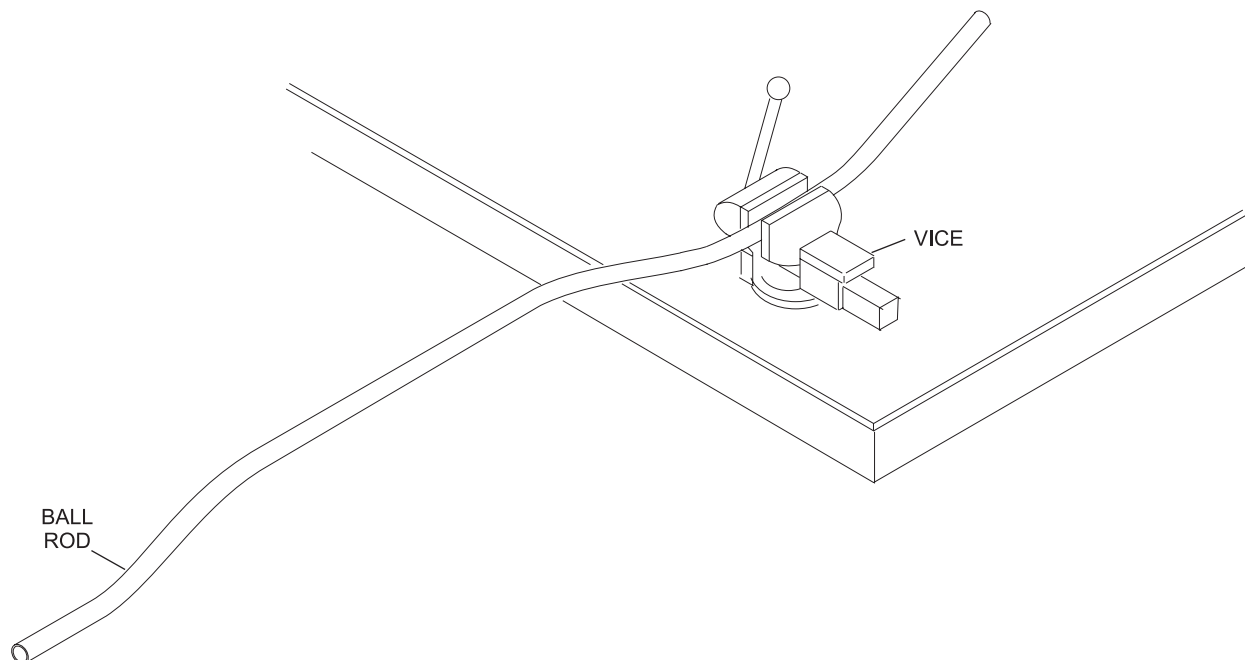

Figure 1

- Slide hose clamp onto plastic tubing and insert rod cover installation tool nozzle into plastic tube. Refer to *Figure 2*.

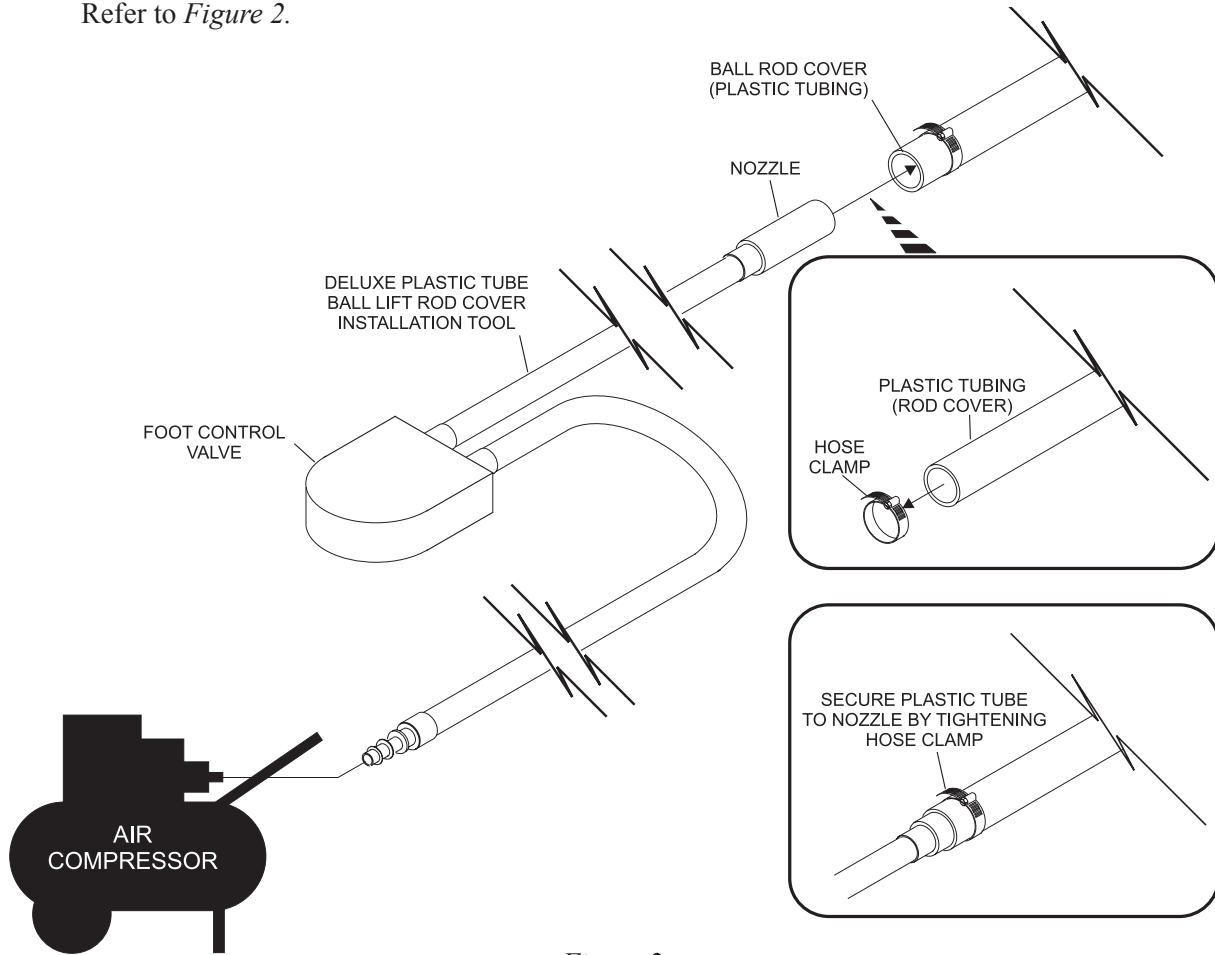

Figure 2

- Secure plastic tube to nozzle using a hose clamp. Refer to *Figure 2*.
- Connect rod cover installation tool to air compressor. Refer to *Figure 2*.
- Use foot control valve of rod installation tool to increase the air pressure in tube.
- Use both hands to slide the plastic tube over ball rod. Refer to *Figure 3*.

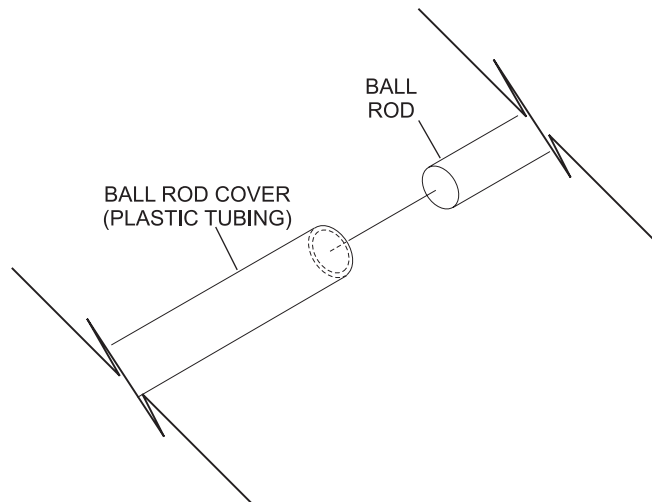

Figure 3

7. Use foot control valve to relieve the air pressure in tube.
8. Loosen hose clamp and remove air nozzle.
9. Trim excess plastic tube from ball rod. Refer to *Figure 4*.

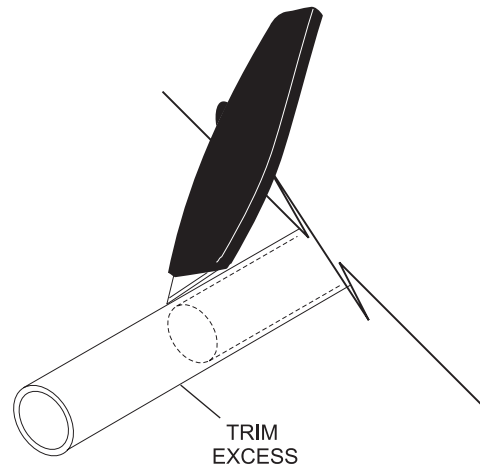

Figure 4