

47-860001-000 Distributor Belt Welding Tool

NOTE: When installing new belts refer to Chart A below for new belt lengths.

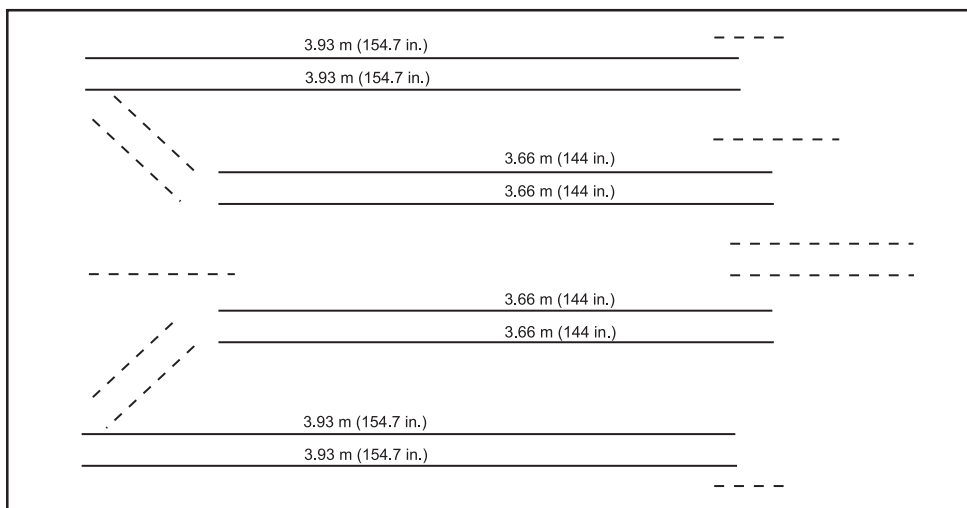
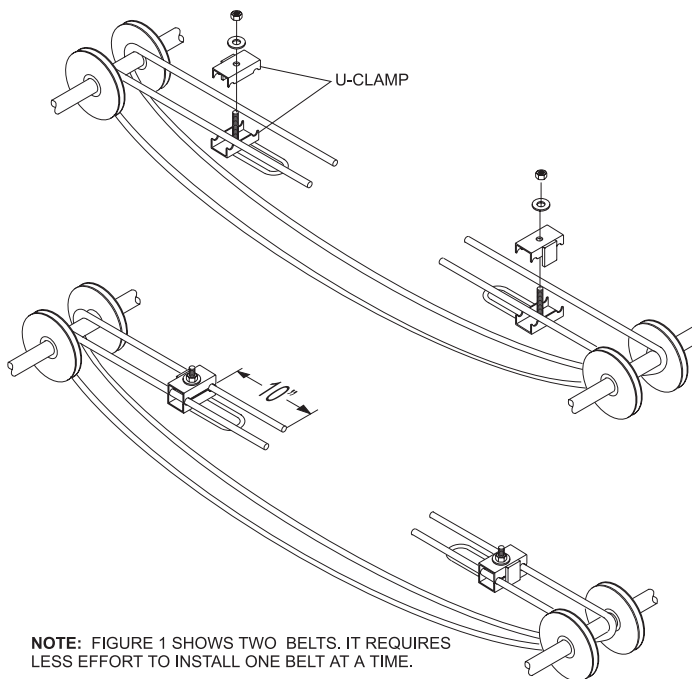

CHART A

1. Install U-Clamps on the new distributor belts as shown in *Figure 1* leaving approximately 10" of belting extending out beyond the end of the U-clamps .



NOTE: FIGURE 1 SHOWS TWO BELTS. IT REQUIRES LESS EFFORT TO INSTALL ONE BELT AT A TIME.

FIGURE 1

NOTE: One end of the belts may be installed over the pulleys, either front or rear.

2. Attach the lever hooks to the U-clamps, with the levers fully open as shown in *Figure 2*.

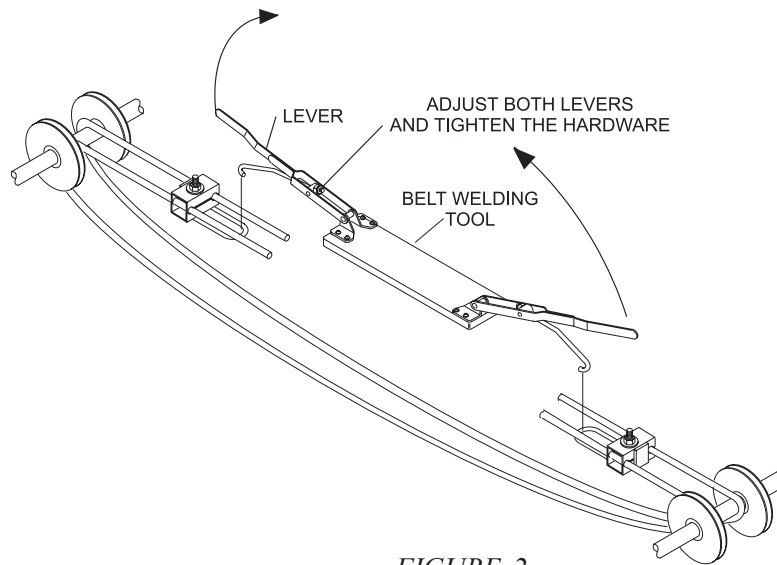

FIGURE 2

3. Close both levers bringing the belts to a workable welding position. Refer to *Figure 3*.

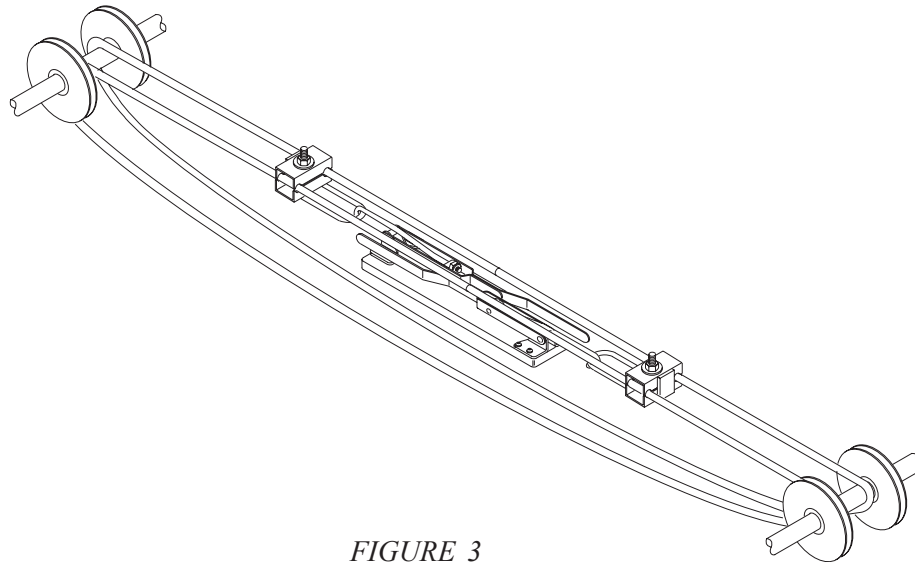

FIGURE 3

NOTE: Be sure to secure the clamp locking mechanism in place by inserting pin through handles.

4. Install the belt welding device and weld belts. Refer to *Figure 4*.

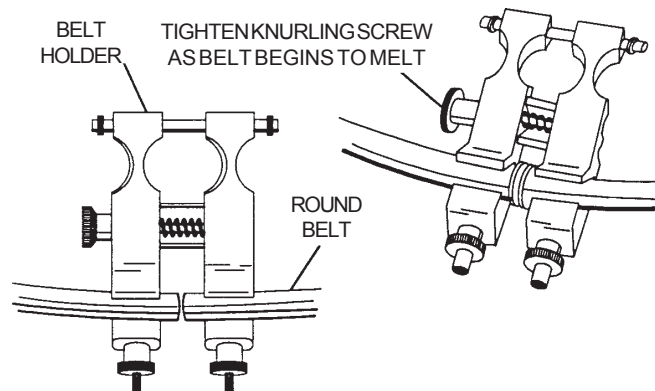

FIGURE 4