

GS-X v.III Guarding Safety Controller Division Interlock

Packaging

1 ea. P1-040051-000



2 ea.	11-696008-000	Interlock - Magnetic Switch, DPST, PILZ
1 ea.	47-142880-000	Interlock Cable Assembly (short)
1 ea.	47-142881-000	Interlock Cable Assembly (long)
2 ea.	47-142884-000	Division Interlock "Y" Cable Assembly
1 ea.	47-086337-000	Spacer - Magnetic Interlock Switch
*1 ea.	47-902004-000	Installation Instructions - Version III Guarding Safety Controller Division Interlock
1 ea.	47-862941-000	Pkg. Double Division Door Magnetic Interlock Hardware
4 ea.	11-052039-001	Washer (5.3 mm)
8 ea.	11-053774-000	Screw - Pan Head C.R. (M4 x 16 mm)
4 ea.	11-054813-001	Screw - Button Head Cap (M5 x 16 mm)
2 ea.	47-086222-000	Bracket - Interlock, Send
2 ea.	47-086223-000	Bracket - Interlock, Receive
5 ea.	11-010819-001	Screw Hex Head Flang Self Drilling (#10-16 x 3/4")

* = PER CENTER

Tools Required

- Adhesive Tape
- Drill Bit 3/32" (2 mm)
- Drill Bit 7/32" (5 mm)
- 3/8" Drill Motor
- 5/16" Socket
- Cross Recess Bit
- Allen Bit (3 mm)

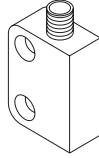
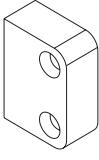
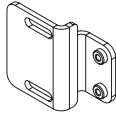
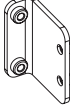
Components

INDEX NUMBER	PART NUMBER	DESCRIPTION	ILLUSTRATION
C1	11-696008-000	INTERLOCK MAGNETIC SWITCH - SEND	
C2	11-696008-000	INTERLOCK MAGNETIC SWITCH - RECEIVE	
C3	47-086222-000	BRACKET- INTERLOCK, SEND	
C4	47-086223-000	BRACKET, INTERLOCK, RECEIVE	
C5	47-086337-000	SPACER MAGNETIC INTERLOCK	

Hardware

INDEX NUMBER	PART NUMBER	DESCRIPTION	ILLUSTRATION
H1	11-052039-001	5.3mm PLAIN WASHER	
H2	11-054813-001	M5x16mm SOCKET BUTTON HEAD SCREW	
H3	11-053774-000	M4x16mm PAN HEAD BRASS SCREW	
H4	11-010819-015	#10-36x3/4" HEX HEAD SELF TAPPING. SCREW	

Division Interlock Electrical Cables

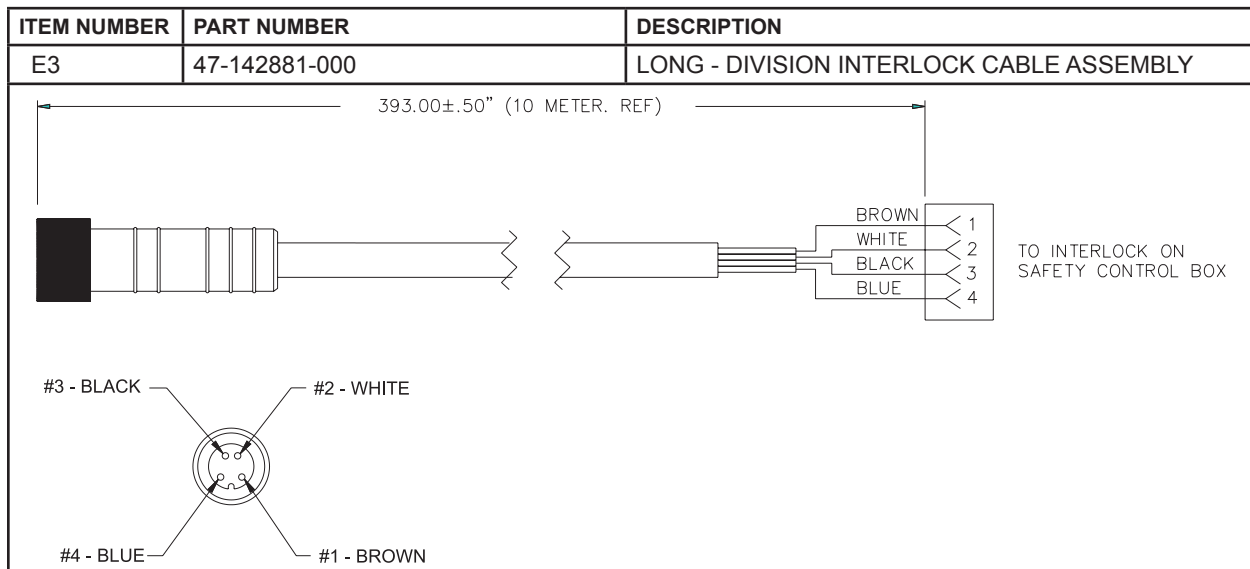
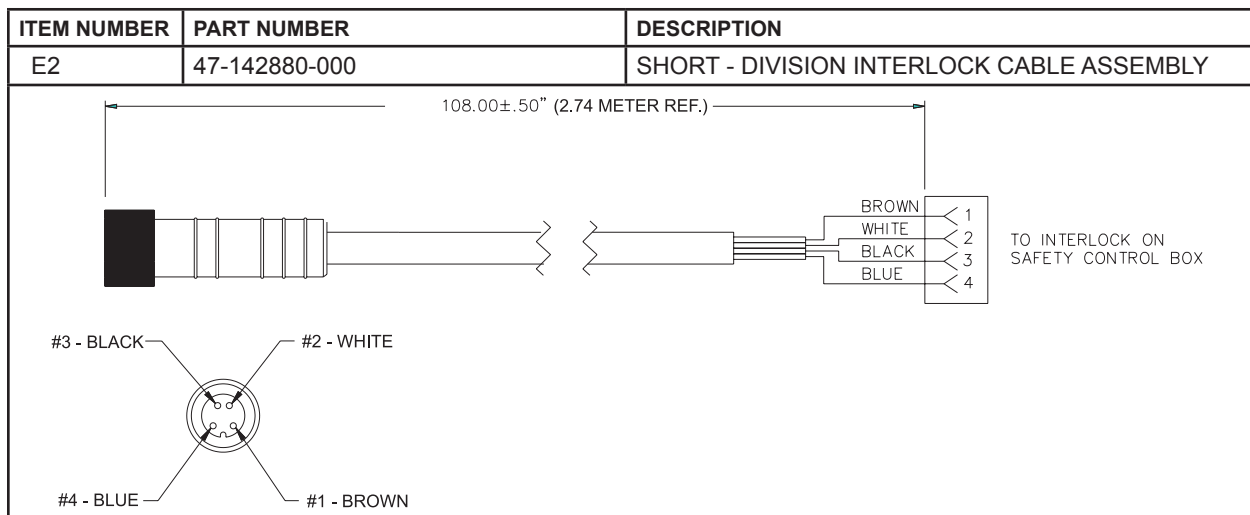
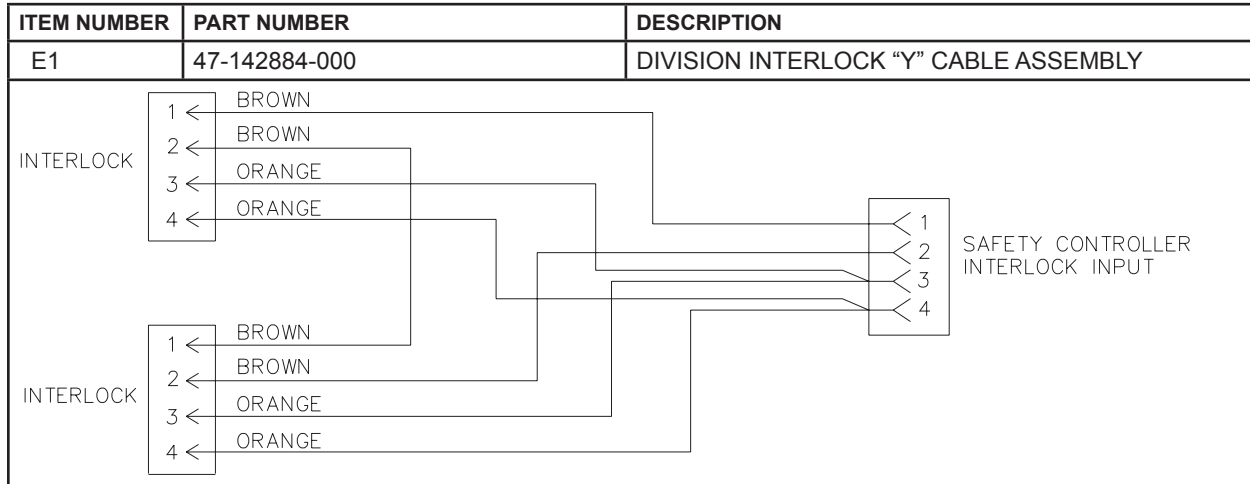

Installation

Safety Interlock - Send

1. Assemble Send Interlock to bracket.
2. Locate mounting hole on post and drill with 3/32" (2 mm) drill bit.
3. Secure Send Unit assembly to post (shim if necessary). Refer to *Figure 1*.

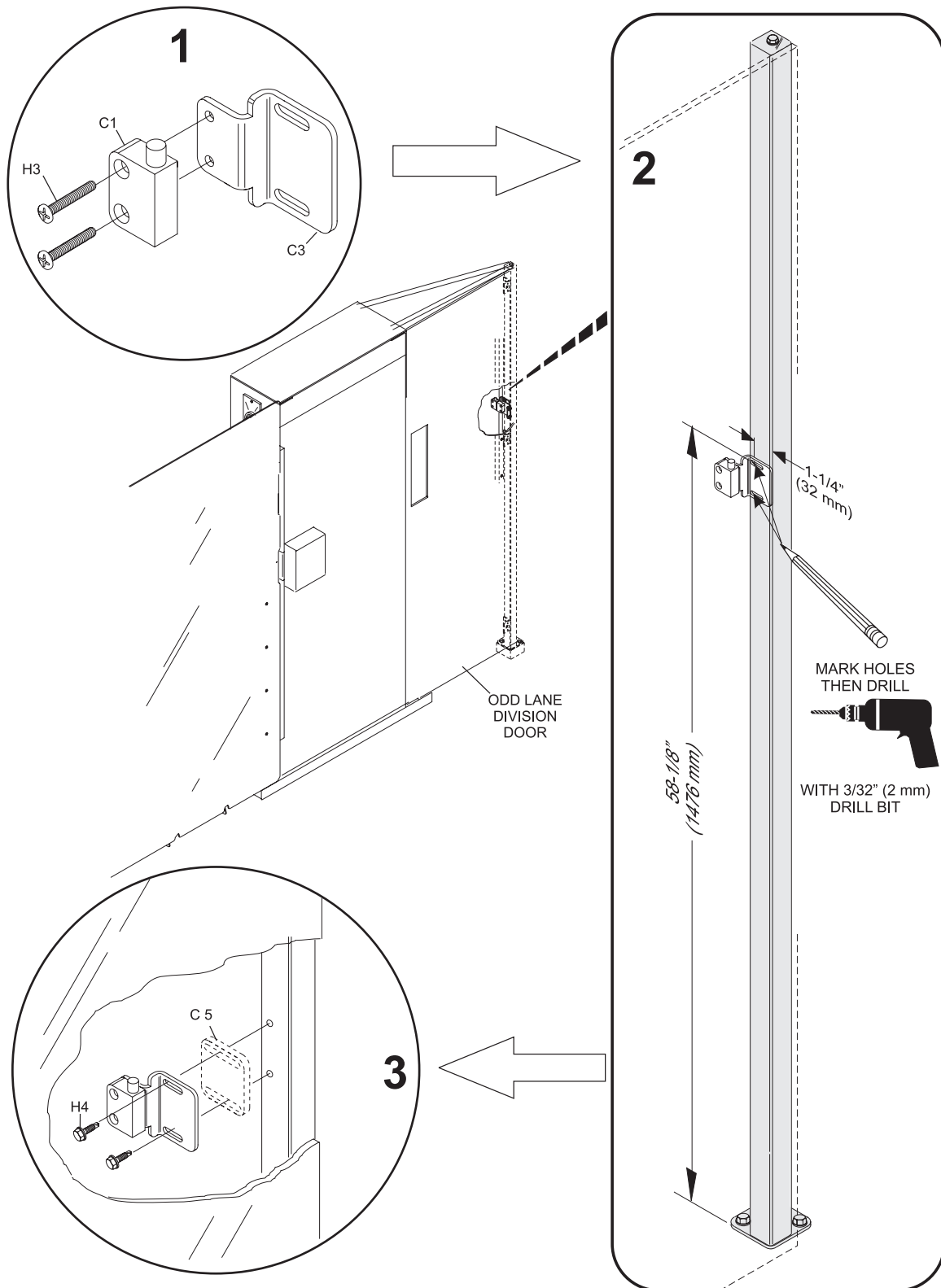

Figure 1
4

Safety Interlock - Receive

1. Assemble Receive Interlock to bracket. Refer to *Figure 2*.

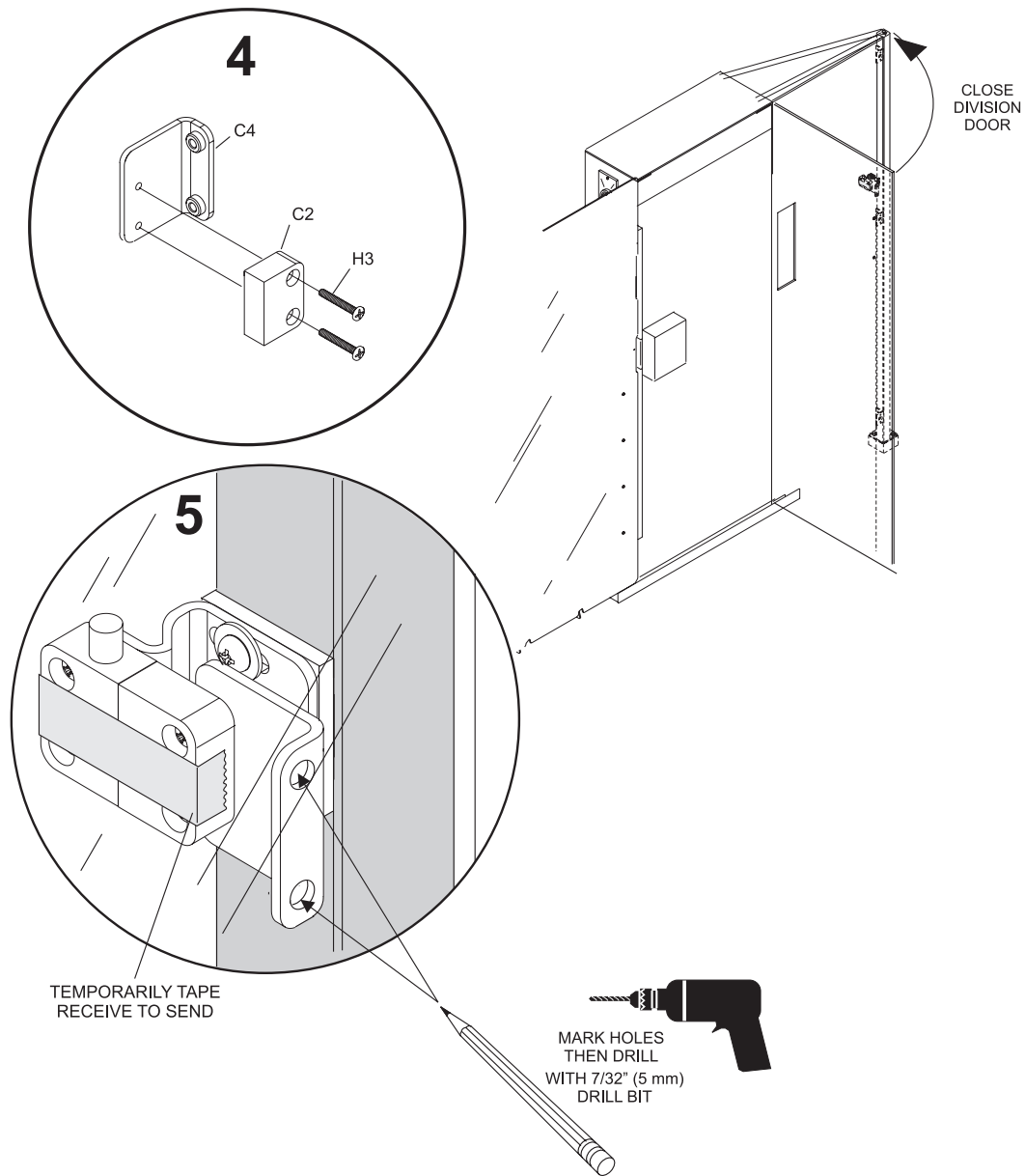

Figure 2

2. Tape Send Interlock to Receive Interlock and close division door.
3. Locate mounting holes on door and drill with 3/32" (5 mm) drill bit.

4. Secure interlock assembly to door. Refer to *Figure 3*.

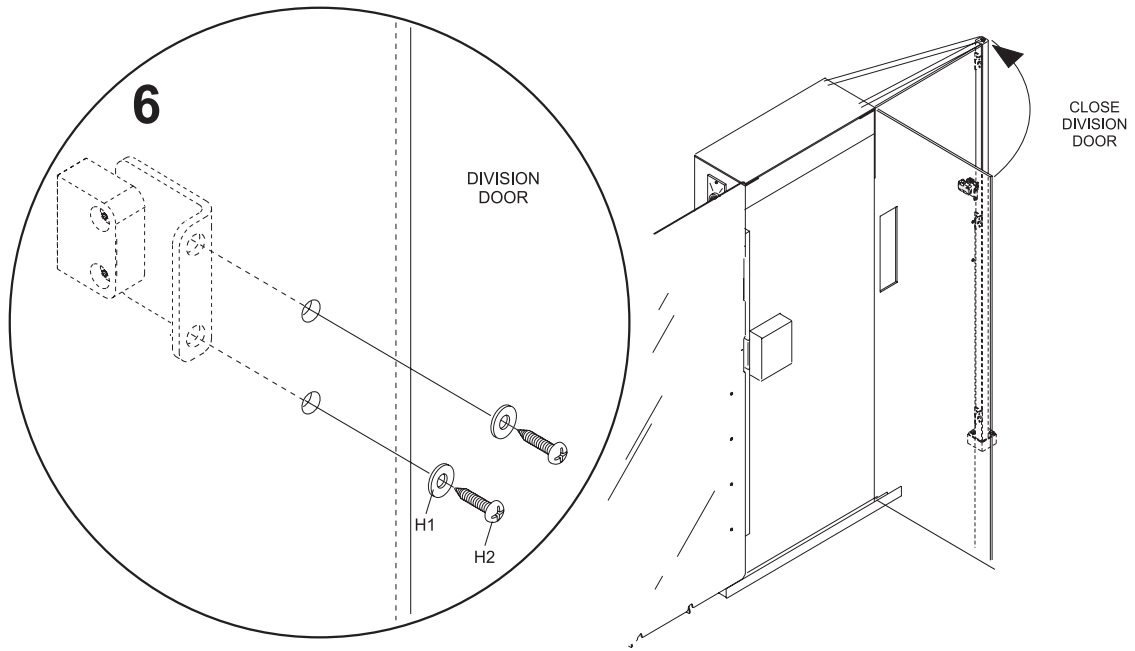

Figure 3

5. Adjust between 0-5 mm space. Refer to *Figure 4*.

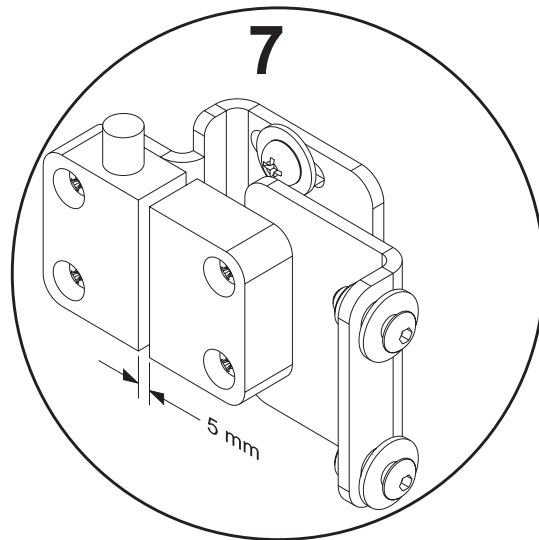

Figure 4

Cable Routing

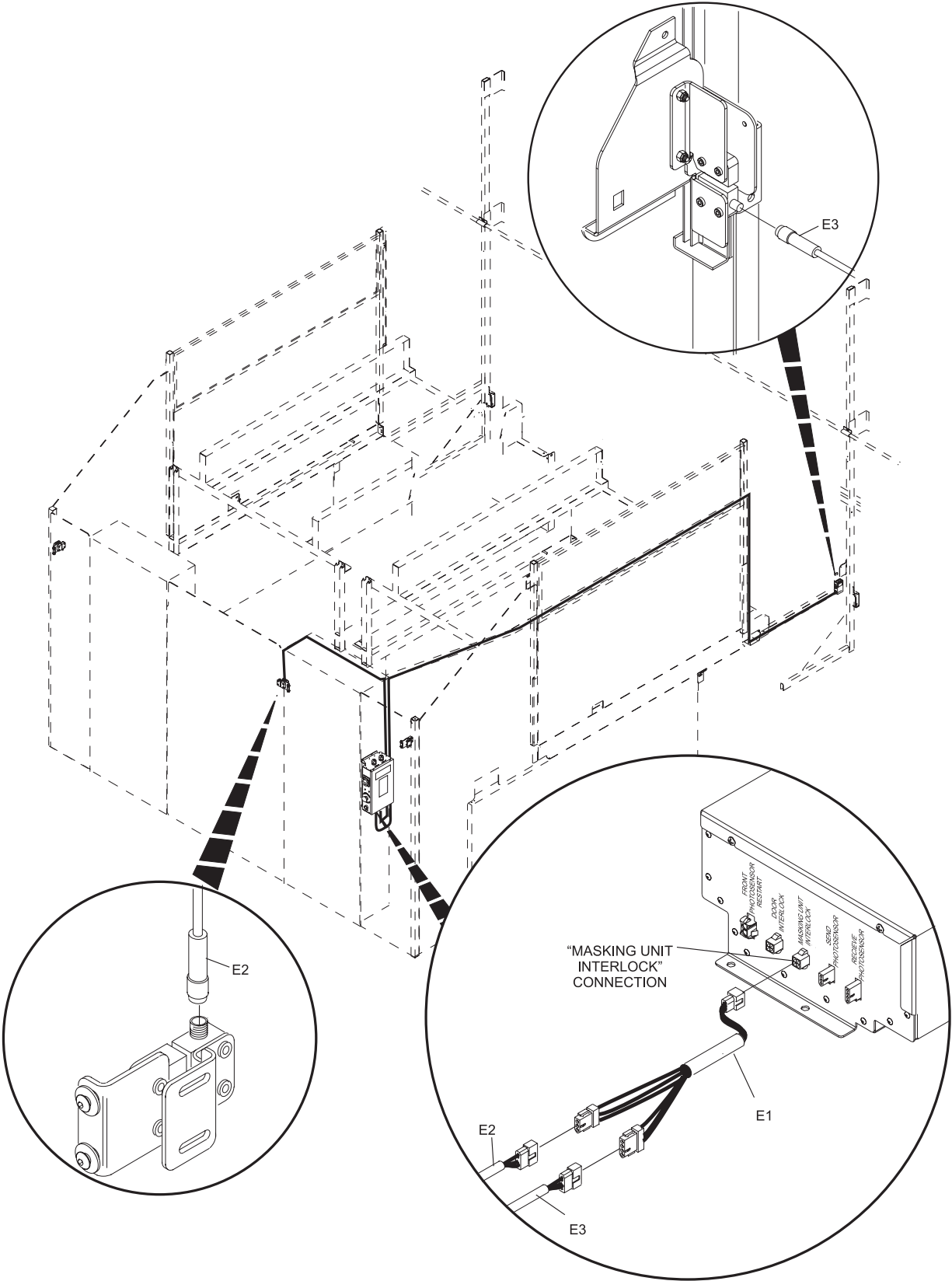

Figure 5

