

SERVICE BULLETIN

Subject: Pinsetter Sweep Switch

Date: 3/10/06

Distribution: Vector Scorer Customers with Brunswick A or A-2 Pinsetters or AMF Pinpotters

Bulletin No. SB06-2

It has come to our attention that some of the Sweep Switch assemblies, package number 57-863172-000, have been assembled incorrectly. The two screws that mount the switch plate are the incorrect size and the lock washers were incorrectly placed under the screw head and are the incorrect type to assemble the switch plate to the sweep switch assembly. Refer to *Figure 1, Incorrect Assembly*.

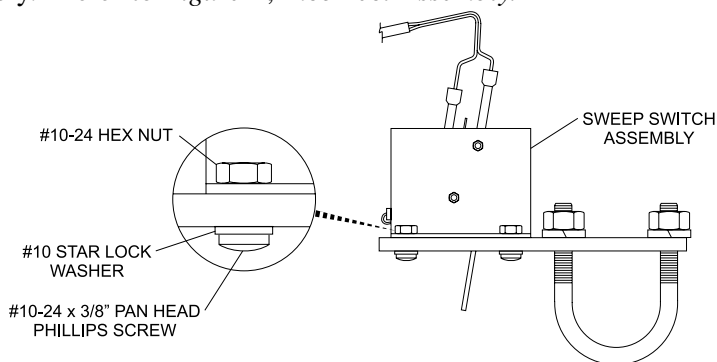

INCORRECT ASSEMBLY
Figure 1

The correct assembly is shown in *Figure 2*. Use a #10-24 x 1/2" pan head Philips screw, part number 11-012328-001, #10 spring lock washer, part number 11-195010-001, and #10-24 hex nut, part number 11-125004-001. These parts can be purchased from a local hardware store or can ship directly to the bowling center from Scott Anderson, 800-944-0325 (USA), 616-379-0325 (International), email – sanderson@northcc.com.

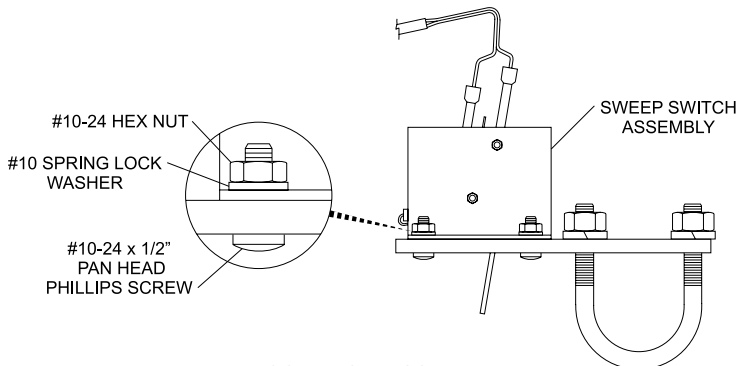

CORRECT ASSEMBLY
Figure 2

If you have questions regarding this or any other Service Bulletin, please contact the Brunswick Customer Response Center at 1-800-323-8141 or 231-725-4966, FAX 231-725-4667, or E-mail http://www.brunswickbowling.com/contact_us

Kord L. Daniels
Kord L. Daniels
Service Product Engineer

David E. Rice
David E. Rice
Director of Worldwide Service