

# SERVICE BULLETIN

**Subject: GS-X Setting Table Cable Assembly**

**Date: 8/18/10**

**Bulletin No. SB10-11**

We are pleased to announce the following changes/improvements for the GS-X Pinsetters.

To address concerns of wire breakage within the cable connecting the Nexgen electronic assembly to the GS-X setting table (part number 47-245420-004), we have changed the cable specification.

To improve flexibility and provide additional protection, the section of the cable with the stripped cable jacket and the flex tubing protecting that section, has been increased in length.

To reduce cable movement during table operation, we have also changed the way the cable attaches to the support bracket. It is suggested that you make the modification to the cable routing on any previously installed pinsetters.

1. At the table cable guide tower, cut and remove the white plastic cable tie located at the third hole from the top. Remove the cable from the 2 cable retaining clips and remove the top clip. Refer to *Figure 1*.

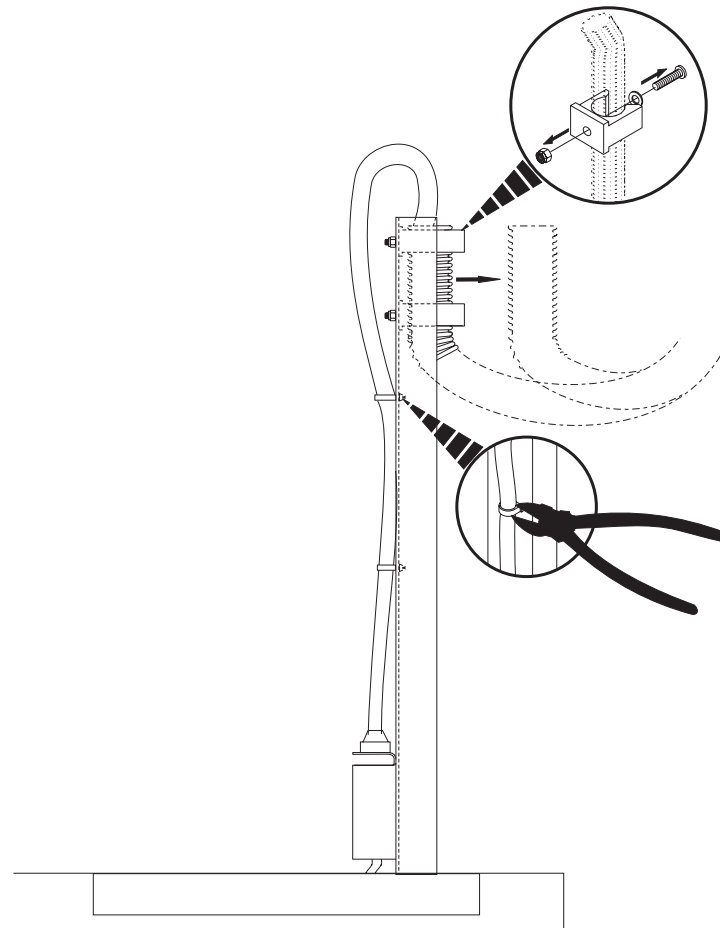

*Figure 1*

2. Install the retaining clip removed in step 1, in the hole previously occupied by the plastic cable tie. Refer to *Figure 2*

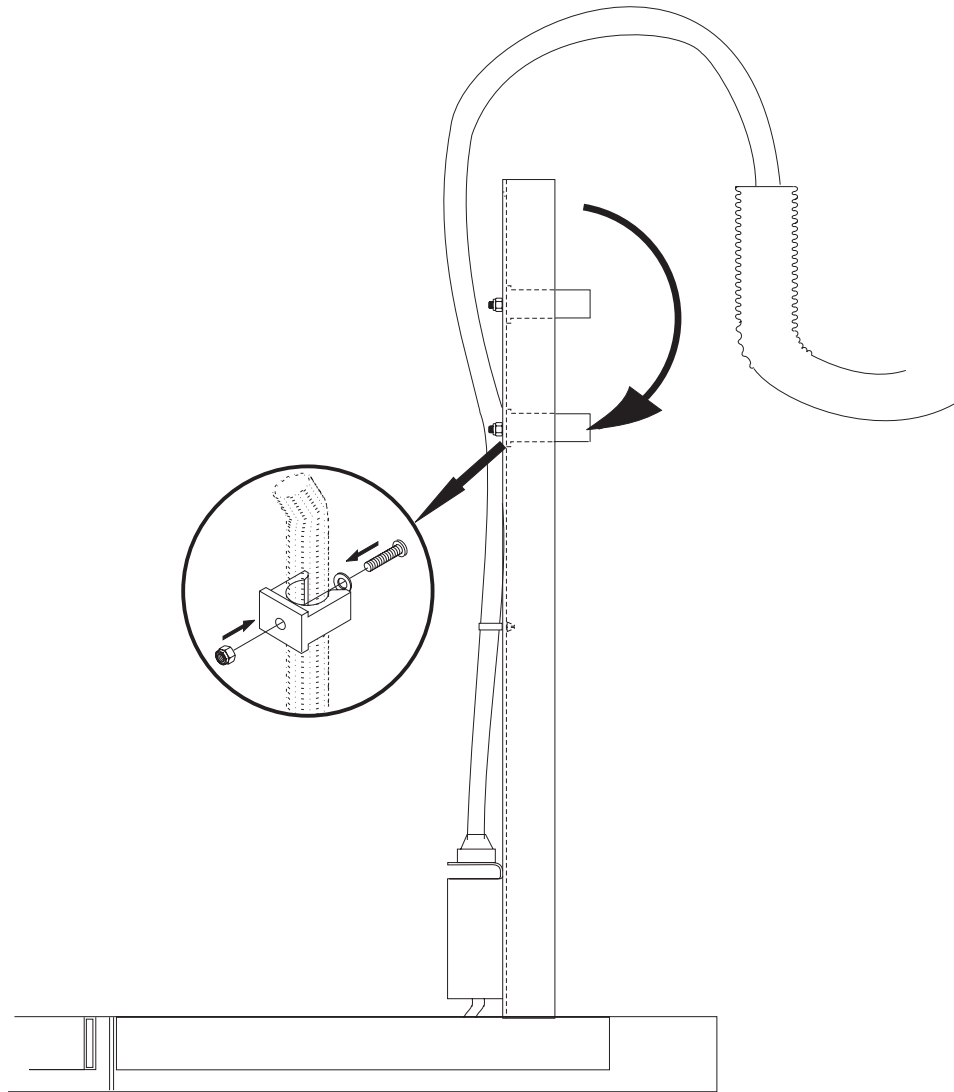

*Figure 2*

3. Reinstall the cable and flex tubing into the retaining clips and using the top hole and a cable tie, secure the table cable and protection conduit tight to the guide tower. Refer to *Figure 3*.

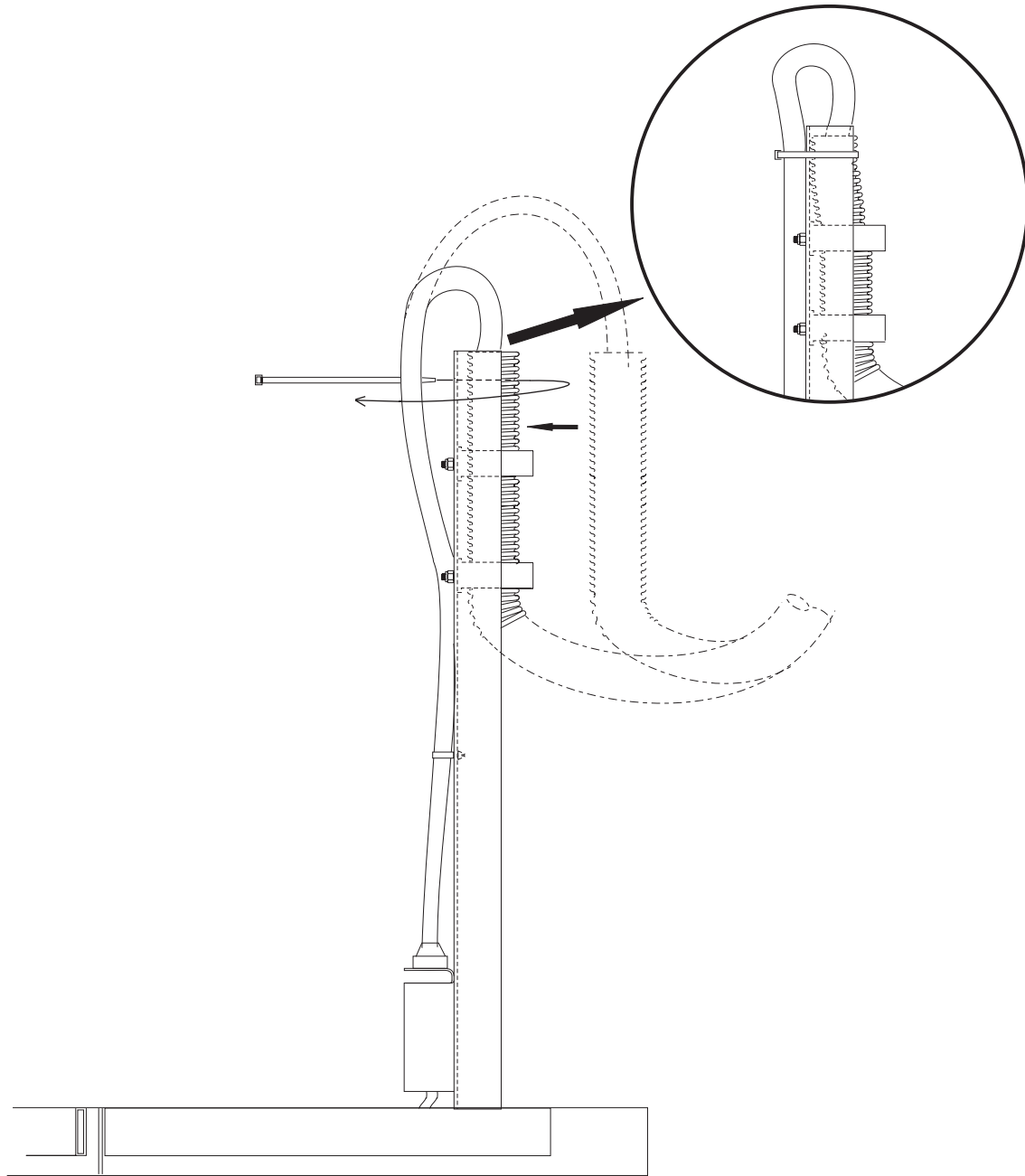

*Figure 3*

4. Verify the cable is pulled out of the cable raceway at the top of the pinsetter frame so that the cable does not bent sharply or is not pulled from the lower retaining clip when the table moves to the new pin setting height. Refer to *Figure 4*.

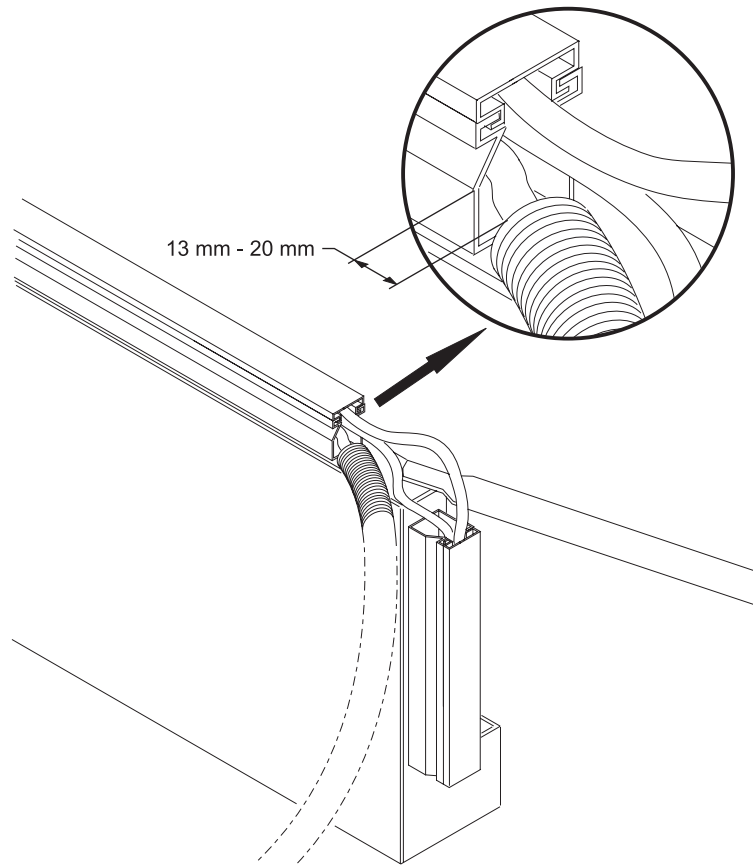

*Figure 4*

If you have questions regarding the information contained in this Service Bulletin, please contact Brunswick Technical Support at 1-800-937-2695 or 231-725-4966, FAX 231-725-4667, or Email [techsupport@brunbowl.com](mailto:techsupport@brunbowl.com) Visit <http://www.brunswickbowling.com/service-support/tech-support/> for electronic files of this and other Service Bulletins.

*William P. Jager*

William P. Jager  
Training & Publications Manager

*David E. Rice*

David E. Rice  
Director of World Wide Service