



Operation & Service Manual

Authority22 v.2.0
Lane Machine

November 2021 / 14-900081-000

Brunswick 

CUSTOMER SERVICE

A tradition in excellence.

Authority22 v.2.0 Operation & Service Manual

© November 2021, by the Brunswick Bowling and Billiards Corporation. All rights reserved.

Past Revisions: May 2009, April 2012

Authority22 is a registered trademark of the Brunswick Bowling and Billiards Corporation.

Reorder Part No. 14-900081-000

Notice: If available, updates to this manual can be found on-line at www.brunswickbowling.com.

Confidential proprietary information. All information contained in this document is subject to change without notice.

Protected by the following U.S. Patent: 7,014,714. Other patents pending.

Brunswick Bowling & Billiards Corporation
Brunswick Bowling Products
525 West Laketon Avenue
Muskegon, MI 49441-2601
U.S.A.

231.725.3300

Contents

Section 1: SAFETY!	7
Notes & Warnings	7
Safety Notice to Users of this Manual	8
General Safety Precautions	8
Grounding	10
Machine Decals.....	10
GUI Safety & Warning Screens	12
Section 2: Getting to Know the Authority22	13
Machine Specifications	14
Dimensions and Weights.....	14
Capacities	15
Machine Features	15
Basic Operations	16
The Cleaning System	17
The Conditioning System	20
The Buffing Operation	21
The Traction Drive System	23
Finding Your Way Around the Authority22	24
Operating Position	24
Transport Position	25
The Graphical User Interface (GUI).....	26
Handle Controls	27
Section 3: Operating the Machine	28
Before You Supply Power	28
Start-Up Procedure	29
Shutting Down	30
Storing the Machine	31
Section 4: Using the Graphical User Interface (GUI)	33
Introduction to the Graphical User Interface (GUI)	34
The Elements of Most Display Screens	34
How to Navigate	3
What Else You Should Know.....	3637
The Operator Screen	38
Changing the Start Lane	39
Changing the End Lane.....	39
Skipping or Repeating Lanes	39
The Pattern Screen	40
Pattern Override	41
Pattern Scheduler	42
Pattern Design	44
Pattern Number and Name.....	44
Mode	45
Forward Speed	45
Start Cleaner Spray	46
Start Squeegee.....	46
Start Oiling.....	47
Split Pattern.....	47
Last Update	48
Additional Pattern Design Screens	48
Pattern Download.....	53
Patterns and Memory	55
Backing Up and Importing Data	60

The System Screen	61
About the System Screen	61
System Center	62
System Machine	63
System Security	64
System Settings	67
Conditioner	70
The Maintenance Screen	71
About the Maintenance Screen	71
Maintenance Counters	72
Maintenance Diagnostics	73
Maintenance Logs	81
Section 5: Maintenance & Service.....	85
Before You Perform Any Maintenance	85
Daily Maintenance	85
Daily Maintenance in Operating Position	86
Daily Maintenance in Transport Position:	88
Weekly Maintenance	90
Weekly Maintenance in Operating Position	90
Weekly Maintenance in Transport Position	91
Annual Maintenance	92
Annual Maintenance in Operating Position	92
Annual Maintenance in Transport Position	94
GUI Maintenance Messages	96
Quick-list of Maintenance Counters	96
How to Replace, Adjust, or Lubricate Parts	97
The Cleaning System	97
The Conditioning System	114
The Buffing System	123
The Drive System	133
General Machine Maintenance	138
Section 6: Troubleshooting.....	141
Sequence of Operation	142
Preparing for Operation on Approach	142
Normal Clean and Condition Operation on Lane	143
The Cleaning System	144
The Conditioning System	148
The Buffing Operation	150
The Traction Drive System	151
Troubleshooting Using the GUI.....	153
Sensors	154
Cleaning	155
Conditioning	156
Drive	157
Tests	158
Error Messages	161
List of Error Messages	162
Error Messages that Appear During Preparation (on approach)	163
Error Messages that Appear During Operation (on the lane)	167
Warning Messages	175
Maintenance Messages	178
Quick-list of Maintenance Counters	178
Mechanical Failures	180
List Of Mechanical Failure Categories	180

Section 7: Pattern Design Theory	188
Pattern Development.....	188
Understanding a Conditioner Pattern	189
Design a Conditioner Pattern	192
Verifying the Conditioner Pattern	194
Adjusting the Conditioner Pattern	194
Authority22 Factory Preset Patterns	195
1. Pattern - House 1.....	197
2. Pattern - House 2.....	198
3. Pattern - Ladies - Seniors	199
4. Pattern - Open Play	200
5. Pattern - Competitive 1	201
6. Pattern - Competitive 2 - Strips	202
7. Pattern - Sport 3:1	203
8. Pattern - Sport 2.5:1	204
9. Pattern - Sport 2:1	205
10. Pattern - Sport Flat	206
Appendix.....	207
Pre-installation Packing List.....	207
Lane Machine Complete with Covers and GUI	207
Electrical Schematics & Diagrams	208

Intentionally Blank Page

Section 1: SAFETY!

Notes & Warnings

Throughout this publication, “Warnings”, and “Cautions” (accompanied by one of the International HAZARD Symbols) are used to alert the mechanic to special instructions concerning a particular service or operation that may be hazardous if performed incorrectly or carelessly. They are defined below. **OBSERVE AND READ THEM CAREFULLY!**

These “Safety Alerts” alone cannot eliminate the hazards that they signal. Strict compliance to these special instructions when performing the service, plus training and “Common Sense” operation are major accident prevention measures.



NOTE or IMPORTANT!:

Will designate significant informational notes.



WARNING!

Will designate a mechanical or nonelectrical alert which could potentially cause personal injury or death.



WARNING!

Will designate electrical alerts which could potentially cause personal injury or death.



CAUTION!

Will designate an alert which could potentially cause product damage.



Will designate grounding alerts.

Safety Notice to Users of this Manual

This manual has been written and published by the Service Department of Brunswick Bowling and Billiards to aid the reader when servicing or installing the products described.

It is assumed that these personnel are familiar with, and have been trained in, the servicing or installation procedures of these products, which includes the use of common mechanic's hand tools and any special Brunswick or recommended tools from other suppliers.

We could not possibly know of and advise the reader of all conceivable procedures by which a service might be performed and of the possible hazards and/or results of each method. We have not attempted any such wide evaluation. Therefore, anyone who uses a service procedure and/or tool, which is not recommended by Brunswick, must first completely satisfy himself that neither his nor the product's safety will be endangered by the service procedure selected.

All information, illustrations and specifications contained in this manual are based on the latest product information available at the time of publication.

It should be kept in mind, while working on the product, that the electrical system is capable of violent and damaging short circuits or severe electrical shocks. When performing any work where electrical terminals could possibly be grounded or touched by the mechanic, the power to the product should be disconnected prior to servicing and remain disconnected until servicing is complete.

General Safety Precautions

In addition to the cautions provided within the manual, you should understand and follow these general principles for safe machine operation.

1. This product is intended only for use in commercial bowling centers and by a trained operator.
2. Do not attempt to undertake any maintenance or service for which you are not qualified.
3. Contact your Brunswick Sales or Service Representative if you are interested in receiving training.
4. Always unplug the machine from the power source before servicing or lifting machine into transport position.
5. Never supply power to machine when it is in transport position.
6. Do not operate with an extension cord or power cord other than the one provided with this machine.
7. Get a partner to help in lifting and lowering to avoid back injury. Take care when lifting or lowering this machine into transport position. Use proper lifting and lowering techniques. Make sure to bend at the knees and use a back support, if needed.

8. Be sure the building's power supply provides properly grounded receptacles and the correct voltage and amps for this machine: 115V, 20A or 230V, 15A service.
9. Do not attempt to make any wiring modifications.
10. Replace fuses with those of the same specifications listed in the wiring diagram in the Appendix of this manual.
11. Use only cleaners and conditioners intended for use with this machine.
12. Always disconnect power before filling tanks.
13. Do not overfill tanks.
14. Do not allow fluid to enter the electrical enclosure or come in contact with electrical components.
15. Be sure all components are dry before supplying power to the machine.
16. Always undertake maintenance operations away from the approach to avoid spilling liquids on the approach and clean up any drips or spills immediately.
17. If you need assistance, please contact your authorized Distributor or the Brunswick Customer Response Center (CRC) in the United States at 1-800-YES-BOWL, or internationally at 231-725-4966. For non emergency support, e-mail crcsupport@brunbowl.com
18. This product should only be operated in 40°F to 105°F (5°C to 40°C) ambient air temperature, in relative humidity not exceeding 50%, and at altitudes up to 6560 feet (2000m) above mean sea level.
19. Transportation and storage temperatures should not exceed -10°F to 130°F (-25°C to +55°C) and should not exceed 160°F (70°C) for more than 24 hours.
20. This machine is designed and manufactured to provide many years of dependable service. Industry experience and common sense are important factors to ensure optimal reliability.
21. Manage the power cord so that it does not get trapped under the lane machine. Replace the protective sleeve and heat shrink tubing on the power cord if they become damaged.
22. Lane machine waste will generally be considered nonhazardous, consisting of lane oils, lane cleaners, and environmental dust/debris. It is understood that the machine owner, and their staff, bear complete responsibility to ensure lane machine waste is properly collected, and disposed of in compliance with local, state, and federal waste disposal laws. Brunswick recommends reaching out to your local waste management authority to coordinate consistent pickups of lane maintenance waste. It should NOT be dumped into a septic tank or sanitary sewer system.

Grounding

This Class I, Single-Phase lane cleaning/conditioning machine must be grounded while in use to protect the operator from electric shock. The machine is provided with a three-conductor cord and a three-contact grounding-type attachment plug to fit the proper grounding-type receptacle. The GREEN/YELLOW conductor in the cord is the grounding wire. Never connect this wire to any other terminal than the grounding pin of the attachment plug.

Machines rated at 115 Volts AC are for use on a nominal 120-Volt circuit and have a grounding plug as shown in Figure 1-1. Make sure that the machine is connected to an outlet having the same configuration as the plug.

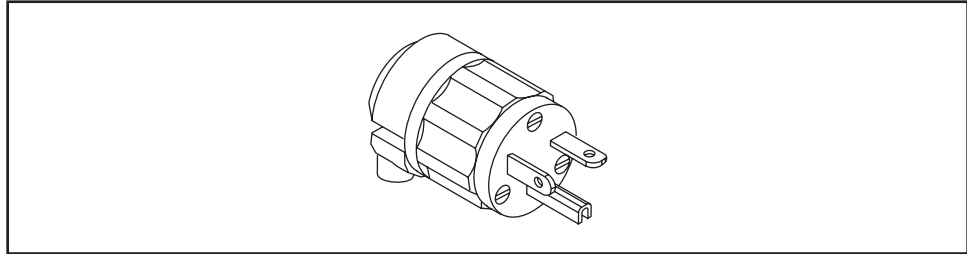

Figure 1-1. 20A Male Plug (125V)

Machines rated at 220-230 Volts AC are for use on a nominal 240-Volt circuit and have a grounding plug as illustrated in Figure 1-2.

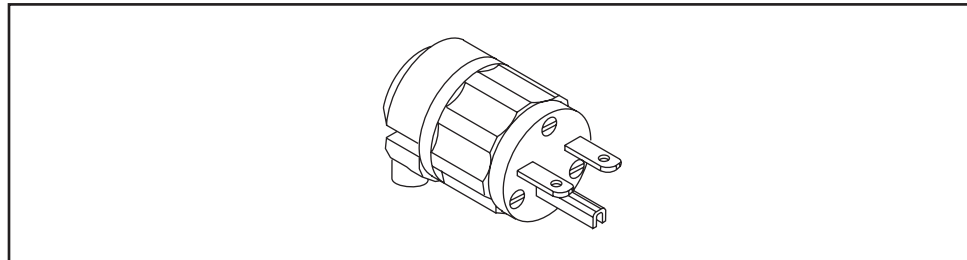

Figure 1-2. 15A Male Plug (230V)

Machine Decals

Daily Maintenance (reorder part number 14-100472-000), Serial Number, Cautions (reorder part number 14-100146-000) and CRC/Warranty Contact (reorder part number 14-100425-000) decals are located on the lane machine as shown in Figures 1-3 and 1-4. Please make sure that you understand and are familiar with the instructions on these decals before operating or servicing this lane machine. If you need assistance or replacement decals, please contact your authorized Distributor or the Brunswick Customer Response Center (CRC) in the United States at 1-800-YES-BOWL, or internationally at 231-725-4966. For non emergency support, e-mail crcsupport@brunbowl.com.

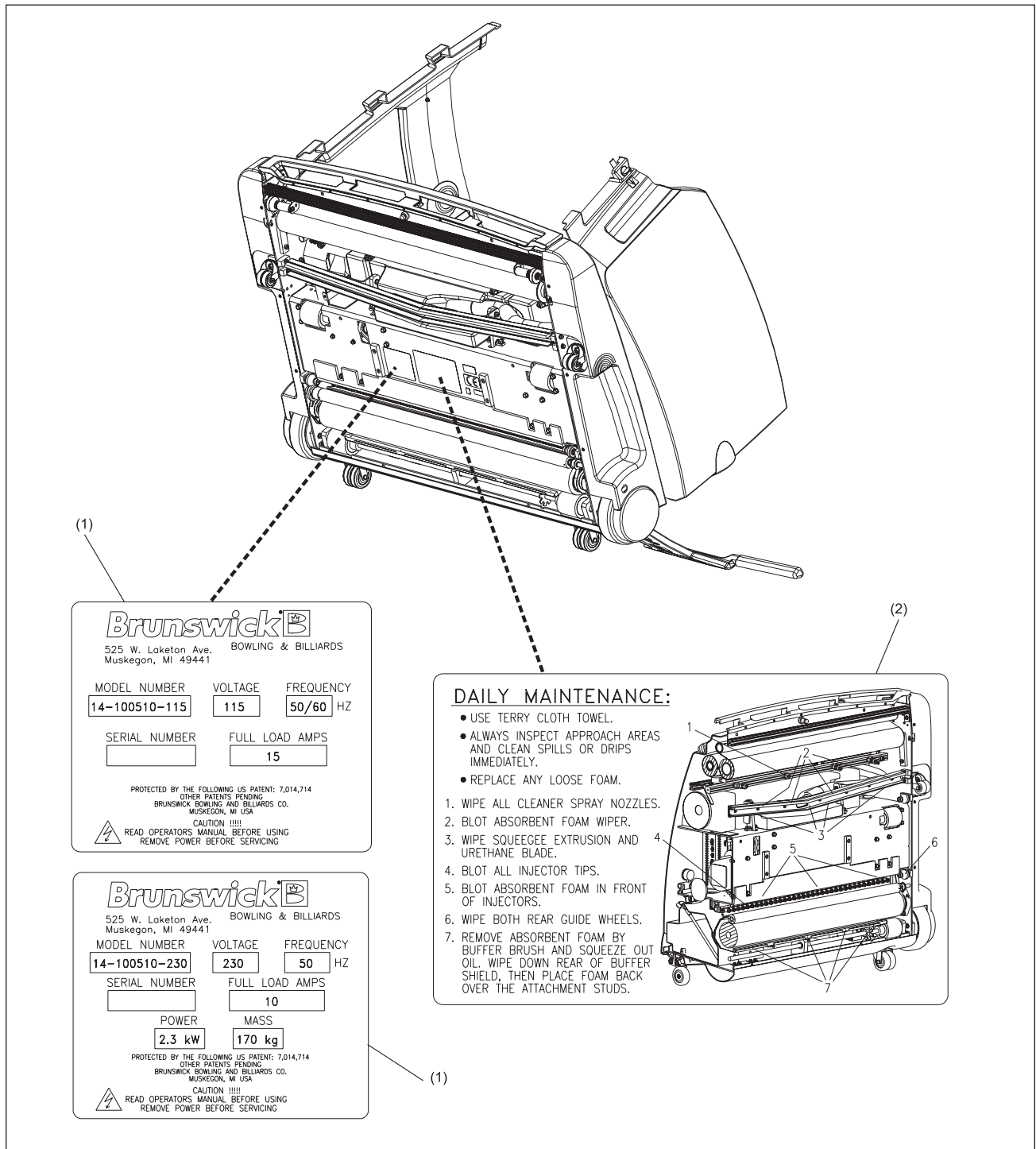

Figure 1-3. Serial Number and Daily Maintenance Decal Locations

(1) SERIAL # DECAL

(2) DAILY MAINTENANCE DECAL
(REORDER PART NUMBER 14-100472-000)

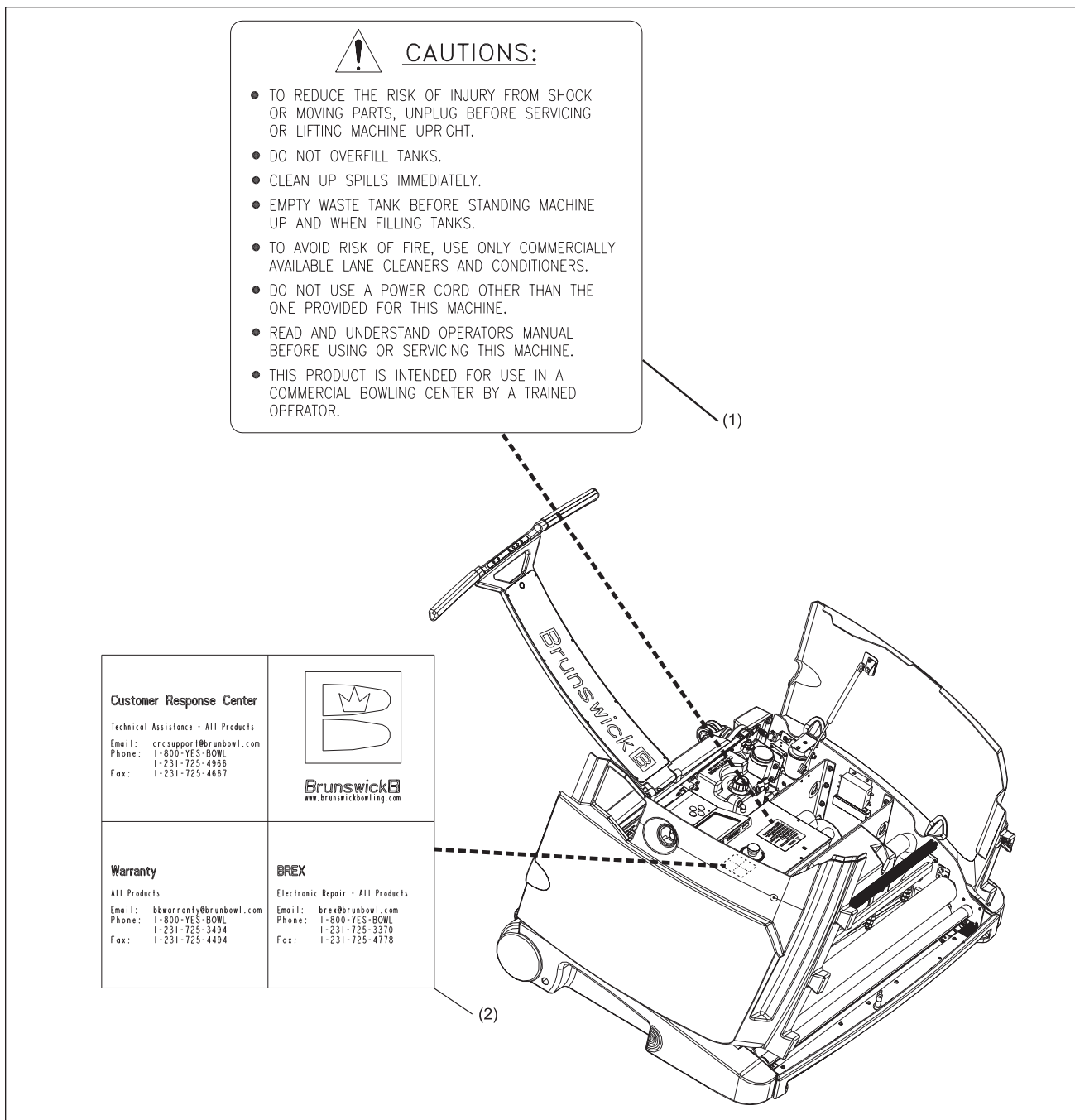

Figure 1-4. Cautions Decal Location

- (1) CAUTION DECAL (REORDER PART NUMBER 14-100146-000)
- (2) CRC/WARRANTY CONTACT DECAL (REORDER PART NUMBER 14-100425-000)

GUI Safety & Warning Screens

There are no user serviceable items inside the Graphical User Interface. If you need assistance, please contact your authorized Distributor or the Brunswick Customer Response Center (CRC) in the United States at 1-800-YES-BOWL, or internationally at 231-725-4966. For non emergency support, e-mail crcsupport@brunbowl.com

Section 2: Getting to Know the Authority22

Before you get started you should understand the basic parts and processes of the machine. This section gives you a general introduction to the machine, its design, and how it works. Illustrations identify important parts and systems and provide references to better understand the machine.

For purposes of orientation and reference, unless stated otherwise, when this manual refers to areas on the machine, it will be assumed the machine is in the operating position, as viewed by the operator at the foul line. Refer to Figure 2-1.

- (1) FRONT
- (2) 7 PIN OR LEFT SIDE
- (3) 10 PIN OR RIGHT SIDE
- (4) REAR
- (5) TOP
- (6) BOTTOM

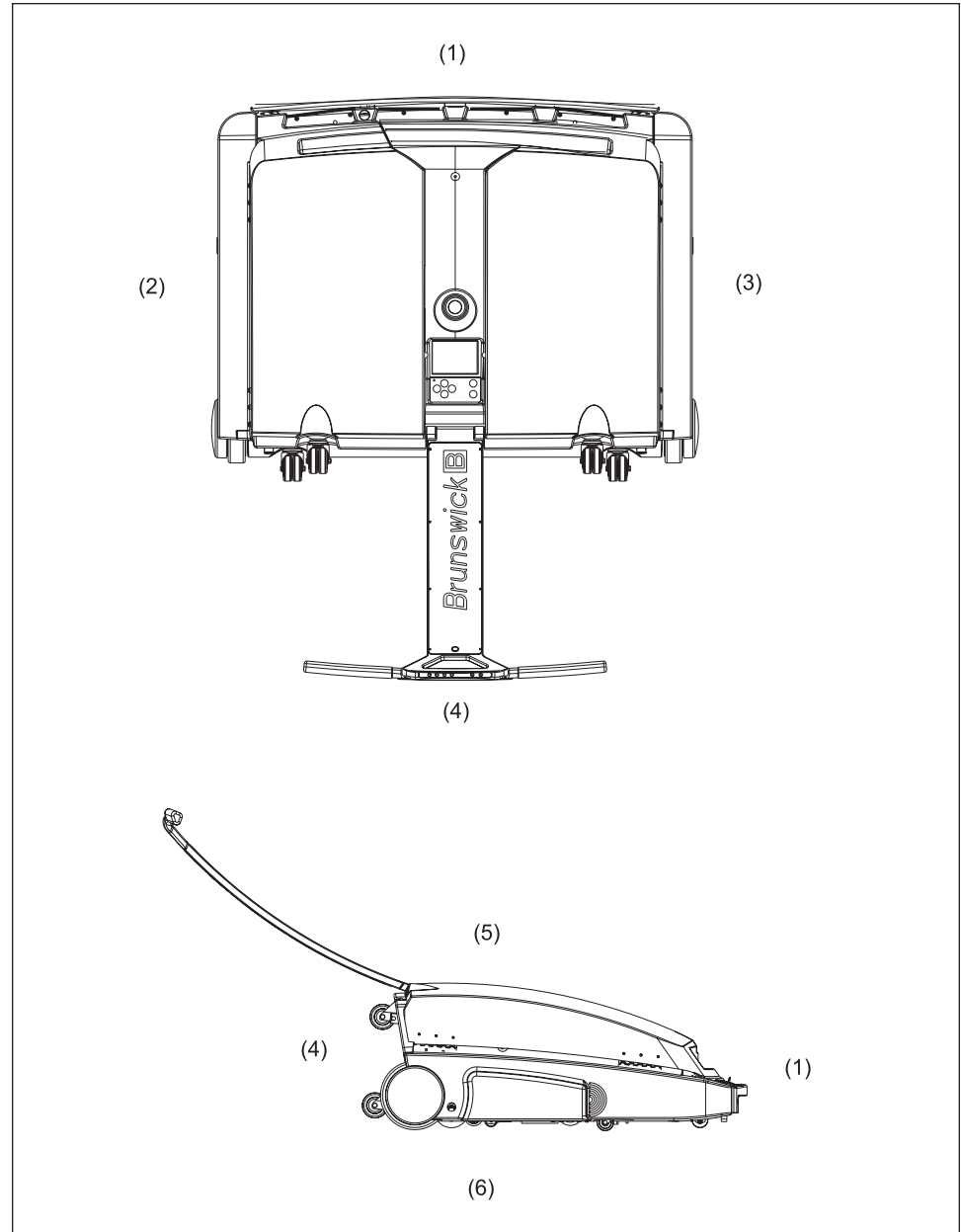

Figure 2-1. Machine Orientation

In this section you will find:

1. Machine Specifications
2. An introduction to the machine's features
3. An overview of basic systems and operation:
 - a. The cleaning system
 - b. The conditioning system
 - c. The buffing operation
 - d. The drive system
4. A visual guide to the machine:
 - a. In operating position (Top View)
 - b. In transport position (Bottom View)
 - c. Graphical User Interface (GUI)
 - d. Handle controls

Machine Specifications

Dimensions and Weights

Refer to Figure 2-2.

Crate Dimensions: 64" x 53" x 26" (1.63m x 1.35m x .66m)

Crate, Machine & Power Cord Weight: 500 lbs. (227 kg)

Machine Dimensions: 57" x 45" x 18" (1.45m x 1.14m x .46m)

Machine Weight: 375 lbs. (170 kg)

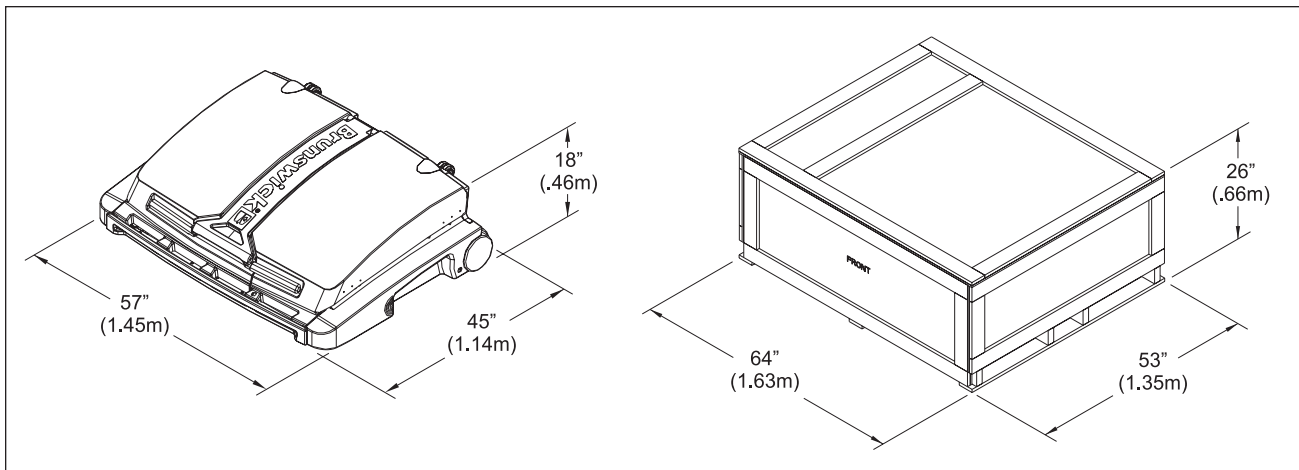

Figure 2-2. Crate & Machine Dimensions

Capacities

Cleaner Tank Capacity: 2.5 gal. = 320 fl. oz. (9.46 l = 9464 ml) up to 40 lanes

Conditioner Tank Capacity: 1.6 qt. = 51 fl. oz. (1.51 l = 1508 ml) up to 60 lanes

Waste Tank Capacity: 2.5 gal. = 320 fl. oz. (9.46 l = 9464 ml) up to 40 lanes

Machine Features

The Authority22 is designed to make lane care easy, reliable, and customized for the needs of individual bowling centers.

- 1. Advanced injector technology.** We have leveraged the technology of our Mercury Marine division to develop a patented injection system with unprecedented precision. Thirty-nine injectors (one for each board) are independently controlled to deliver precise amounts of conditioner directly to the lane surface. Oil output is measured in industry-standard “units of oil calculations.”
- 2. Powerful and rugged controller.** A powerful computer system monitors operations, tells you when the machine needs maintenance, and lets you customize just about every aspect of operation – from daily schedules, to cleaner patterns, to conditioner volumes and more.
- 3. Intuitive Graphical User Interface (GUI).** The graphical user interface is deliberately simple to use and understand, without extensive training or instruction. Operating procedures are logical and intuitive. The display screen and GUIs are large, easy to see, and use.
- 4. Unparalleled customization.** The Authority22 lets you design your own conditioner patterns, decide when you want to start and stop most operations, set up schedules that vary by time of day, day of the week, or set of lanes. No other machine offers as much built-in flexibility in operation.
- 5. Superior pattern control.** The Authority22 comes pre-programmed with high-performance conditioner patterns that can be graphically displayed and easily customized. A center’s existing patterns can be easily programmed in the Authority22, so you can duplicate favorite patterns without trial and error.
- 6. High efficiency.** The Authority22 works faster than competitors’ machines—it takes just 74 seconds to clean and condition a lane at max clean speed and 64 seconds at quick clean speed. And with 25% more cleaner and recovery tank capacity than existing machines, you can complete up to 40 lanes without refilling or emptying tanks.
- 7. Easy maintenance.** Many commonly replaced parts change out in half the time of similar machines.

8. **Enhanced ergonomics.** Most of the machine's basic functions can be controlled from a standing position using the handle controls. By putting common functions at the operator's fingertips, we've reduced unnecessary stooping, and bending. Larger fixed wheels make it easy to move the machine with less effort and better control than other designs.

Basic Operations

The Authority22 performs a variety of cleaning and conditioning operations simultaneously as it travels the lane surface. When the machine is in clean and condition mode, it follows this sequence of operation:

1. Begins forward travel down the lane
2. Dusts
3. Applies cleaning solution
4. Scrubs the surface of the lane
5. Channels cleaning solution and waste to the vacuum system
6. Vacuums cleaning solution and waste into the waste recovery tank
7. Applies fresh conditioner directly to the lane surface
8. Buffs the conditioner on the lane until it reaches the pattern end distance you specify
9. Stops conditioner application
10. Continues cleaning the lane through the end of the pin deck
11. Stops cleaning and travel
12. Reverses direction
13. Continues to buff the conditioner in the oil pattern
14. Stops buffing at programmed distance from the foul line
15. Prepares to start the next lane

The Cleaning System

The cleaning system removes dust and dirt from the lane surface, applies cleaning solution to the lane, scrubs the surface, and then removes all waste from the lane, collecting it in the waste recovery tank. The basic operation of the cleaning system is as follows:

1. The **duster contact roller** lowers so the duster cloth is in contact with the lane surface, removes dust and dirt from the lane surface as the machine travels toward the pin deck. Refer to Figure 2-3.

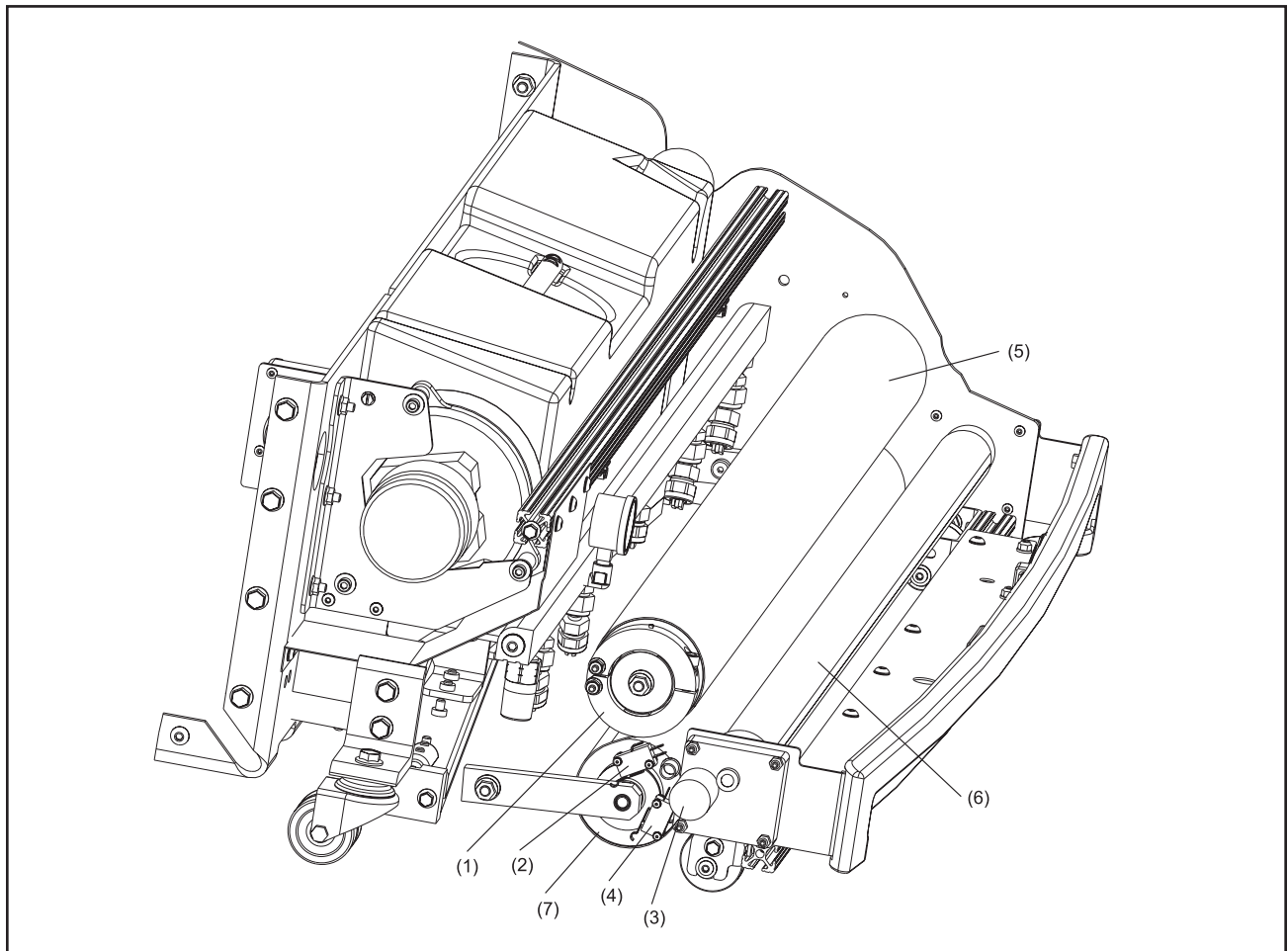

Figure 2-3. Duster Cloth System

- | | | |
|---------------------------|------------------------------|-------------------------------|
| (1) DUSTER CLUTCH | (2) DUSTER UP SWITCH | (3) DUSTER CLOTH MOTOR |
| (4) DUSTER DOWN SWITCH | (5) DUSTER CLOTH SUPPLY ROLL | (6) DUSTER CLOTH TAKE UP ROLL |
| (7) DUSTER CONTACT ROLLER | | |

- The **cleaner spray nozzles** apply a continuous spray of cleaning fluid to the lane. Refer to Figure 2-4.

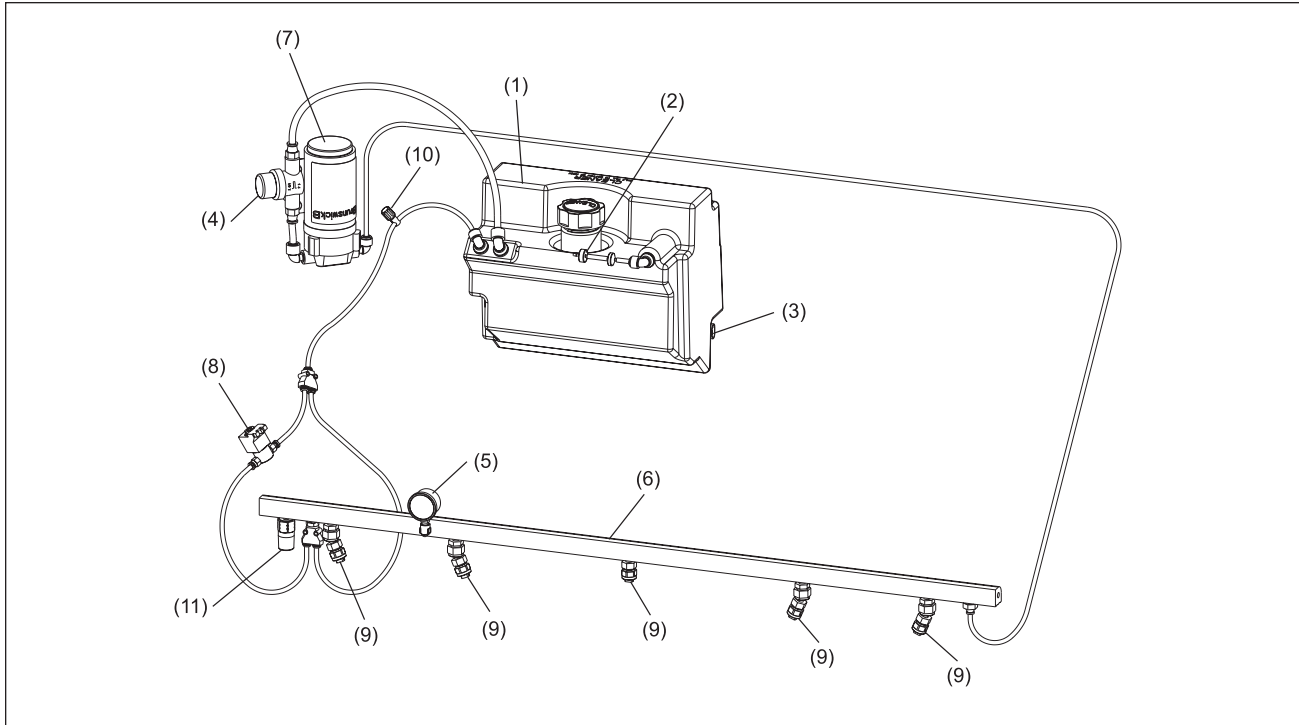

Figure 2-4. Cleaner Spray System

- | | | |
|---------------------------|------------------------------|-----------------------------------|
| (1) CLEANER SUPPLY TANK | (2) CLEANER VENT VALVE | (3) CLEANER LEVEL
FLOAT SENSOR |
| (4) CLEANER SCREEN FILTER | (5) CLEANER PRESSURE GAUGE | (6) CLEANER MANIFOLD |
| (7) CLEANER PUMP | (8) CLEANER BYPASS VALVE | (9) CLEANER SPRAY
NOZZLES |
| (10) PINCH VALVE | (11) CLEANER PRESSURE SENSOR | |

- The **absorbent wiper** agitates the cleaning fluid on the lane to loosen dirt and old conditioner from the surface. Refer to Figure 2-5.
- The **squeegee blade** channels waste fluid to the center of the **squeegee head assembly**. Refer to Figure 2-5.
- All waste fluid is suctioned into the **waste recovery tank**. Refer to Figure 2-5.

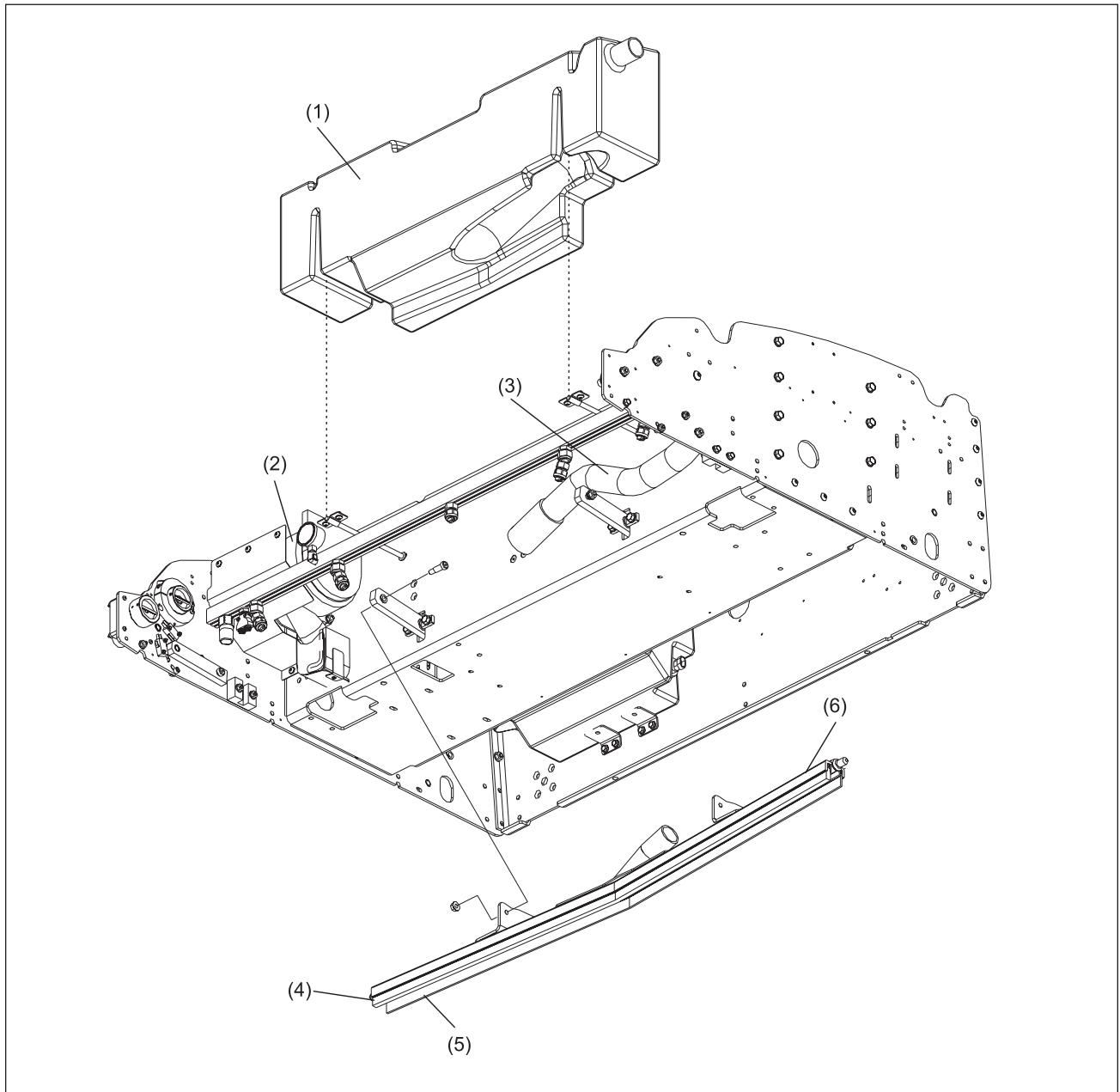

Figure 2-5. Cleaner Vacuum System - Bottom View

(1) WASTE RECOVERY TANK
 (4) ABSORBENT WIPER

(2) VACUUM MOTOR ASSEMBLY
 (5) SQUEEGEE BLADE

(3) WASTE HOSE
 (6) SQUEEGEE HEAD ASSEMBLY

6. When the machine reaches the end of the lane, the duster cloth and squeegee assembly raise for the return travel to the approach .
7. The duster cloth take-up roller continues to rotate to advance new duster cloth for use on the next lane. Refer back to Figure 2-3.

The Conditioning System

The conditioning system is a highly advanced, computer controlled, direct-application system that applies conditioner to the lane surface in any pattern specified by the bowling center. Here's how it works:

1. 39 **conditioner injectors** mounted on a pressurized injector rail assembly apply conditioner to the lane surface according to the selected pattern. Refer to Figure 2-6.
2. Conditioner injectors are individually controlled to disperse conditioner the width of one board, in pulses every 1.2 inches along the length of the lane surface, allowing precise application and volume control.

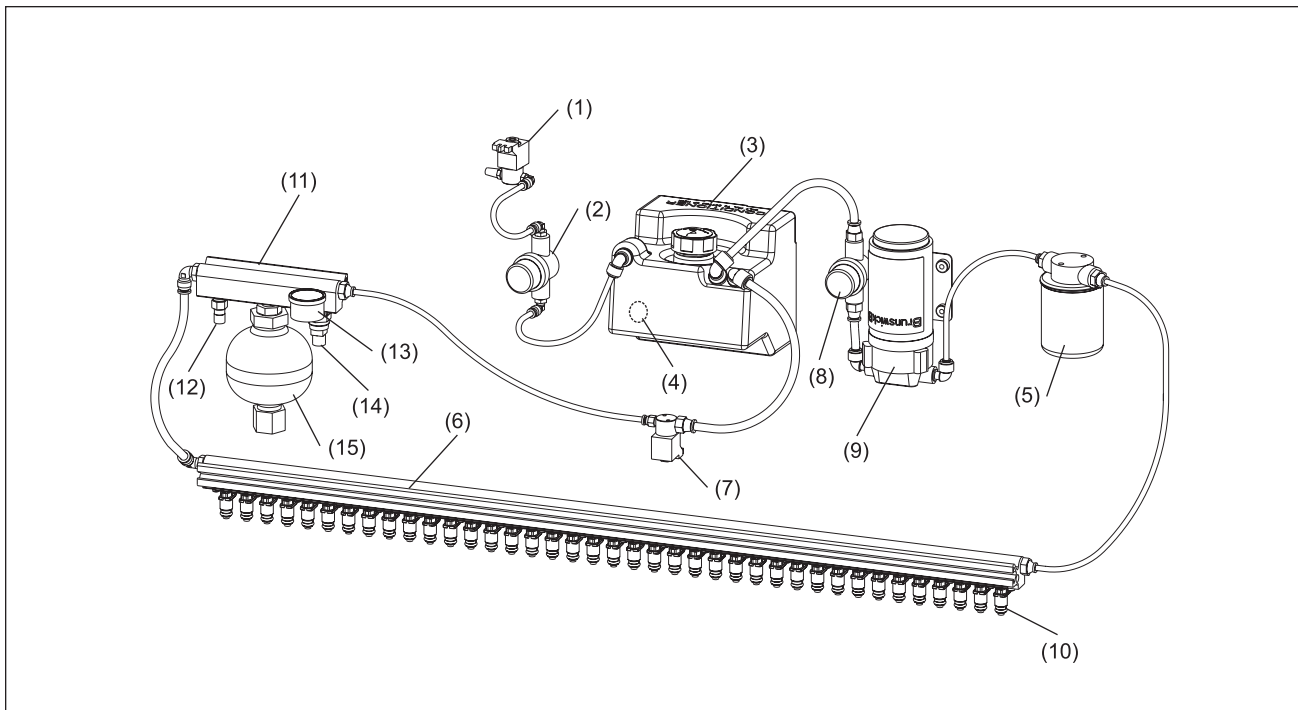

Figure 2-6. Conditioning System

- | | | |
|--|------------------------------------|-------------------------------------|
| (1) CONDITIONER VENT VALVE | (2) CONDITIONER OVERFLOW RESERVOIR | (3) CONDITIONER SUPPLY TANK |
| (4) CONDITIONER LEVEL FLOAT SENSOR | (5) CONDITIONER SPIN-ON FILTER | (6) INJECTOR RAIL ASSEMBLY |
| (7) CONDITIONER PRESSURE CONTROL VALVE | (8) CONDITIONER SCREEN FILTER | (9) CONDITIONER PUMP |
| (10) CONDITIONER INJECTOR | (11) ACCUMULATOR RAIL | (12) CONDITIONER TEMPERATURE SENSOR |
| (13) CONDITIONER PRESSURE GAUGE | (14) CONDITIONER PRESSURE SENSOR | (15) ACCUMULATOR |



NOTE:

For more information on designing or selecting conditioning patterns, see **The Pattern Screen** section in “Section 4: Using the Graphical User Interface” and “Section 7: Pattern Design Theory.”

The Buffing Operation

The buffing operation blends the conditioner on the lane surface.

1. The **buffer lifting** motor lowers the **buffer brush** to the lane surface and the **buffer drive motor** rotates the **buffer brush** in the direction of forward machine travel (clockwise, when viewed from the right side of the brush assembly) blending the injected conditioner lengthwise on the surface of the lane. Refer to Figure 2-7.
2. The **dispersion roller** rotates in the same direction of the buffer brush, contacting only the buffer brush and blending the conditioner amongst the bristles through side-to-side oscillation. Refer to Figure 2-7.

- (1) BUFFER BRUSH
- (2) DISPERSION ROLLER
- (3) BUFFER LIFTING MOTOR
- (4) DISPERSION ROLLER MOTOR
- (5) BUFFER DRIVE MOTOR
- (6) BUFFER DRIVE BELT

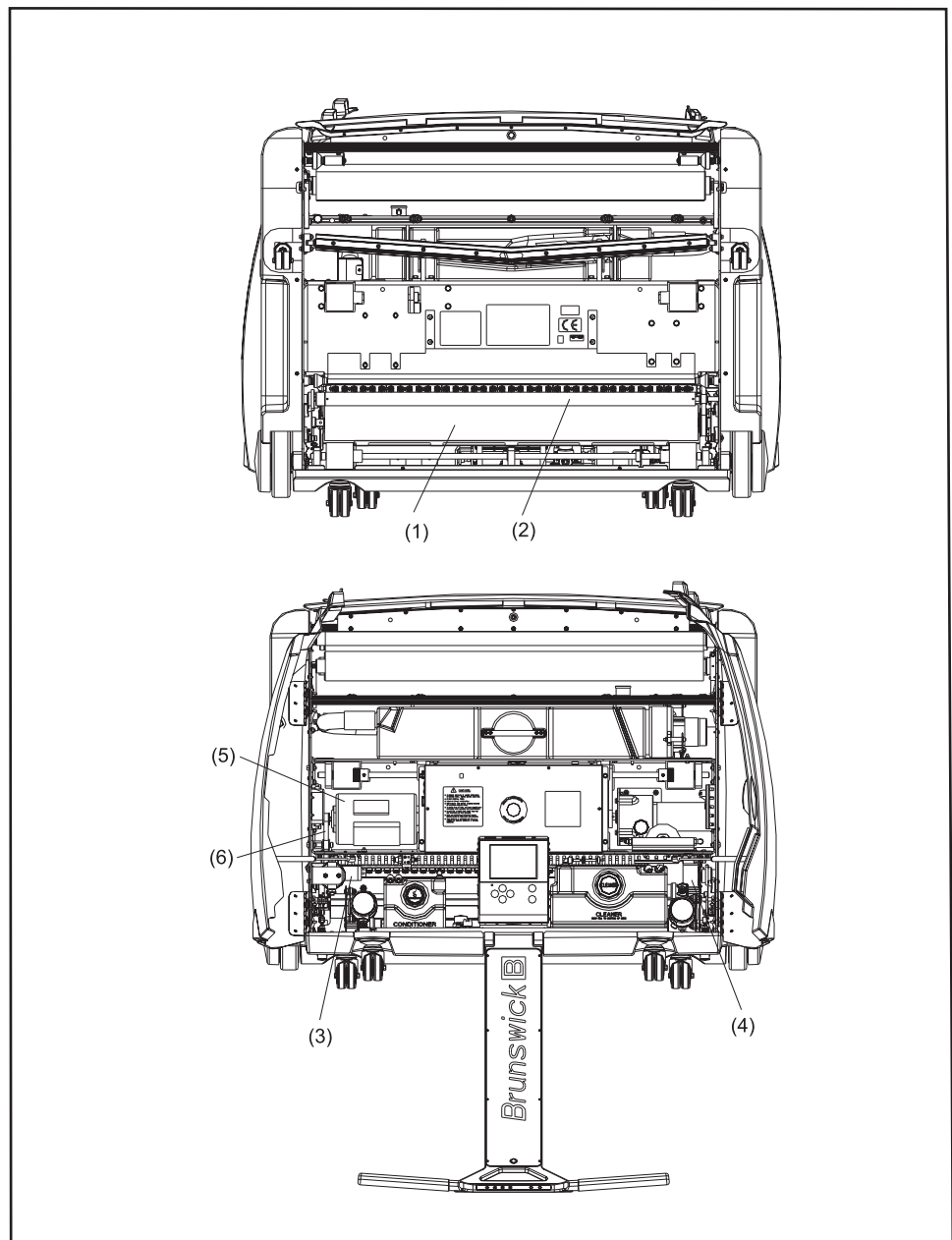

Figure 2-7. Buffing System

3. When the machine reaches the end of the conditioning pattern, the buffer brush and dispersion roller stop rotating and the buffer brush is raised up and out of contact with the lane surface until the machine reaches the pin deck.
4. When the machine returns from the end of the lane to the conditioner pattern section of the lane, the buffer brush will lower back to the lane surface if conditioner values are programmed in last zone. (If last zone conditioner values equals zero, the last zone is skipped and the buffer brush lowers at the next to last zone.) The buffer brush will continue blending the conditioner until the machine reaches the programmed distance from the foul line.
5. The buffer lifting motor will raise the buffer brush and the brush will stop turning. The machine will continue traveling back to the foul line and stop.

The Traction Drive System

The traction drive system moves the machine forward and in reverse as it cleans and conditions. Sensors detect the machine's travel and position on the lane and send signals to the controller, which activates and deactivates other operations based on the machine's position on the lane.

1. The **traction drive motor** turns a chain which rotates the **traction wheel drive shaft**. The **traction drive wheels** contact the lane surface and as the traction wheel drive shaft turns, the machine begins to move down the lane towards the pin deck. Refer to Figure 2-8.
2. When the **end of lane sensor** travels past the end of the pin deck, the machine travels an additional 1.2 feet, so the cleaning system can clear the pin deck, and then the controller turns off the motor.
3. The traction drive motor turns on and the machine returns to the foul line at the same rate of speed as it moved in forward travel.
4. As the machine nears the foul line, the controller turns off the traction drive motor and it stops at the foul line.
5. Once the machine stops at the foul line, the GUI displays the number of the next lane to be maintained.

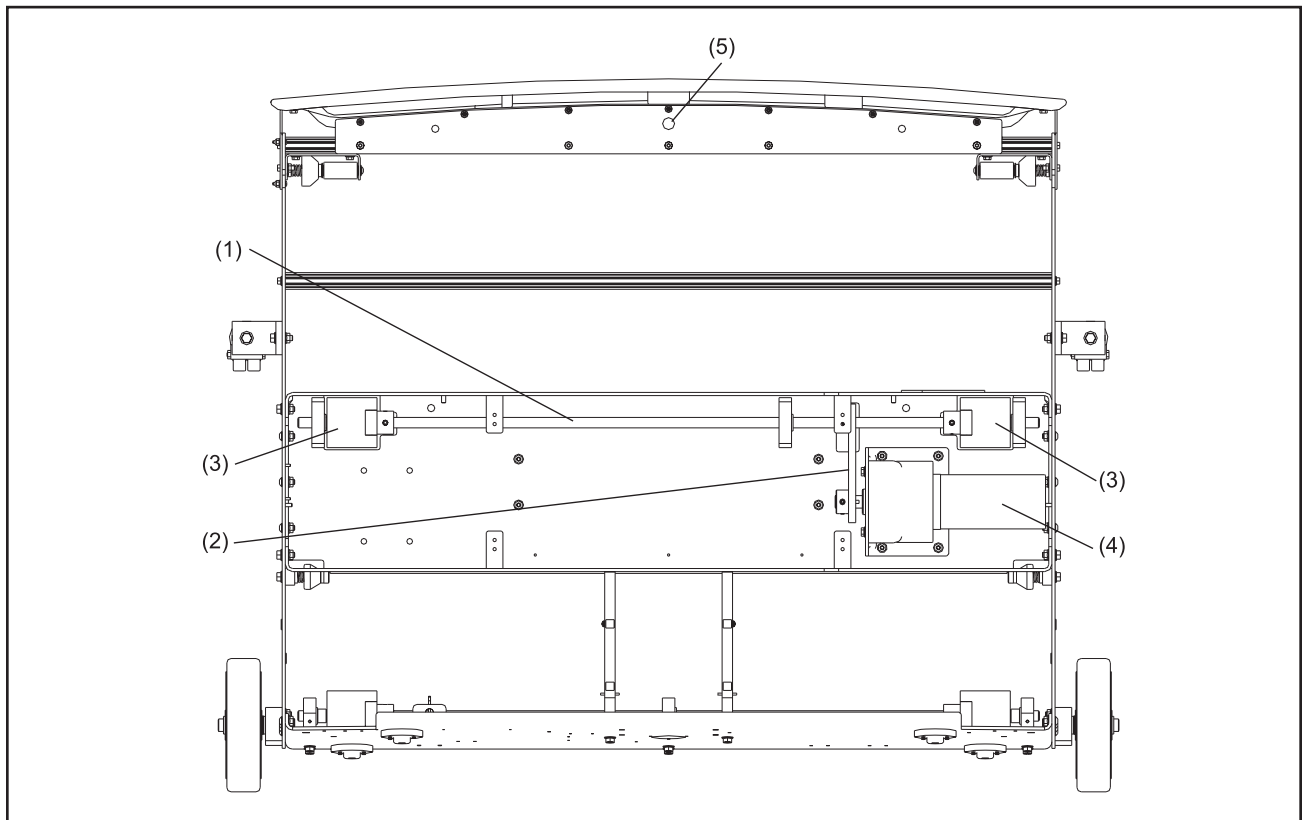

Figure 2-8. Traction Drive System

(1) TRACTION WHEEL DRIVE SHAFT
(4) TRACTION DRIVE MOTOR

(2) TRACTION MOTOR CHAIN
(5) END OF LANE SENSOR

(3) TRACTION DRIVE WHEELS

Finding Your Way Around the Authority22

This section gives you an illustrated “tour” of the machine to help you locate important components and systems.

Operating Position

Most maintenance operations are made with the machine in “operating position” with the covers open. Refer to Figure 2-9.



WARNING!

Brunswick recommends using a partner whenever possible to help with lifting or lowering the machine from the operating position. Take care when lowering this machine into the operating position. Use proper lifting and lowering techniques, bend at the knees, and use a back support, if needed.

- (1) WASTE RECOVERY TANK
- (2) BUFFER DRIVE MOTOR
- (3) BUFFER LIFTING MOTOR
- (4) LEFT CORD KILL ASSEMBLY
- (5) RIGHT CORD KILL ASSEMBLY
- (6) CONDITIONER PUMP
- (7) CONDITIONER SUPPLY TANK
- (8) CLEANER PUMP
- (9) CONDITIONER SPIN-ON
- (10) CLEANER SUPPLY TANK
- (11) ELECTRONICS ENCLOSURE
- (12) GRAPHICAL USER INTERFACE (GUI)
- (13) DISPERSION ROLLER MOTOR
- (14) TRACTION DRIVE MOTOR
- (15) TRACTION WHEELS
- (16) VACUUM MOTOR ASSEMBLY
- (17) DUSTER CLOTH MOTOR
- (18) DUSTER CLOTH SUPPLY ROLL
- (19) DUSTER CLOTH TAKE UP ROLL
- (20) END-OF-LANE SENSOR FRONT
- (21) HANDLE/BUMPER
- (22) EMERGENCY SHUT OFF SWITCH
- (23) HANDLE KEYPAD

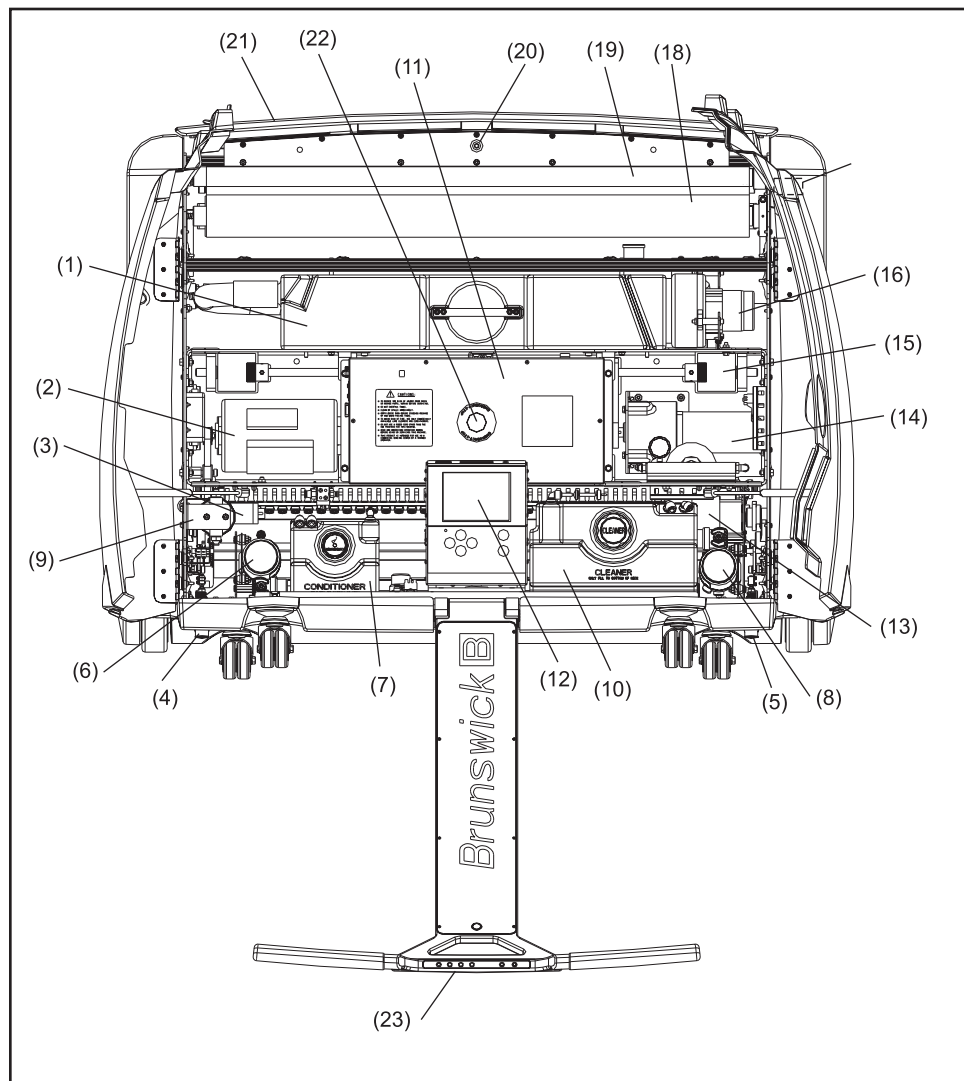

Figure 2-9. Operating Position

Transport Position

Some maintenance procedures are performed with the machine in “transport position,” with the machine upright, its underside exposed, and resting on its transport casters. refer to Figure 2-10.



WARNING!

Always unplug power cord from the machine before servicing or lifting machine into transport position. Never supply power to machine when it is in transport position.



WARNING!

Brunswick recommends using a partner whenever possible to help with lifting or lowering the machine from the operating position. Take care when lowering this machine into the operating position. Use proper lifting and lowering techniques, bend at the knees, and use a back support, if needed.

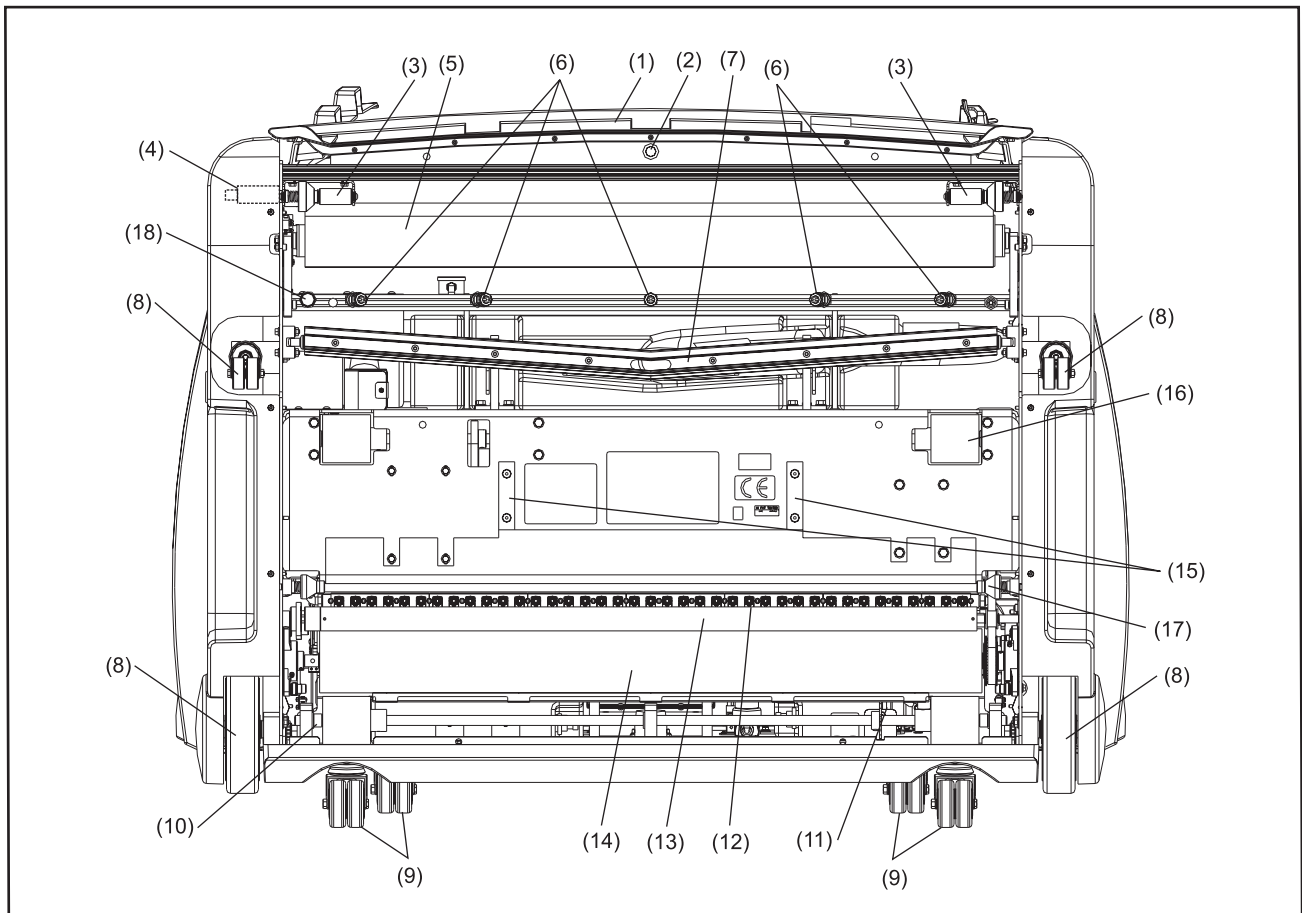

Figure 2-10. Transport Position

- | | | |
|-----------------------------------|---------------------------|------------------------------|
| (1) FRONT HANDLE/BUMPER | (2) END-OF-LANE SENSOR | (3) TRANSITION ROLLERS |
| (4) DUSTER CLOTH MOTOR | (5) DUSTER CONTACT ROLLER | (6) CLEANER SPRAY NOZZLES |
| (7) VACUUM SQUEEGEE HEAD ASSEMBLY | (8) LANE TO LANE WHEELS | (9) TRANSPORT CASTERS |
| (10) REAR SHAFT ASSEMBLY | (11) DISTANCE ENCODER | (12) CONDITIONER INJECTORS |
| (13) DISPERSION ROLLER | (14) BUFFER BRUSH | (15) SKID PLATES |
| (16) TRACTION DRIVE WHEELS | (17) GUIDE ROLLERS | (18) CLEANER PRESSURE SENSOR |

The Graphical User Interface (GUI)

The GUI lets you monitor the machine's operation while you use it. It also alerts you to maintenance needs, tells you about past service records, gives access to conditioning programs, and much more. Refer to Figure 2-11.



NOTE:

For detailed information on using the GUI, see *Section 4: Graphical User Interface*.

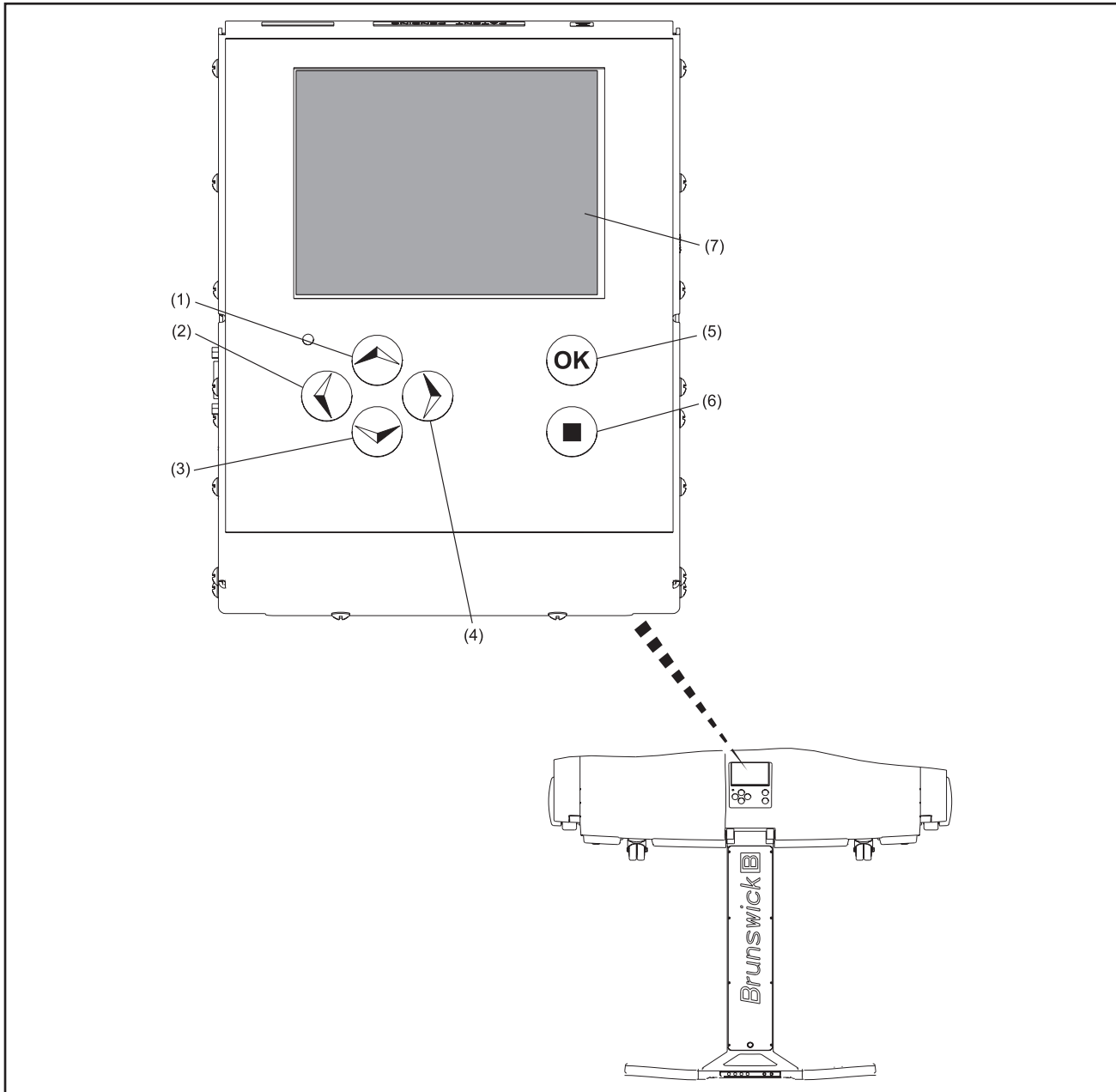

Figure 2-11. Graphical User Interface (GUI)

- | | | |
|------------------------|-----------------------|-----------------------|
| (1) UP ARROW BUTTON | (2) LEFT ARROW BUTTON | (3) DOWN ARROW BUTTON |
| (4) RIGHT ARROW BUTTON | (5) OK BUTTON | (6) EXIT BUTTON |
| (7) DISPLAY SCREEN | | |

Handle Controls

All of the machine's operations can be controlled using the control pad on the machine's handle. By putting the machine functions on the handle, we reduce stooping, kneeling and bending and allow more healthful operation of the machine. Refer to Figure 2-12.

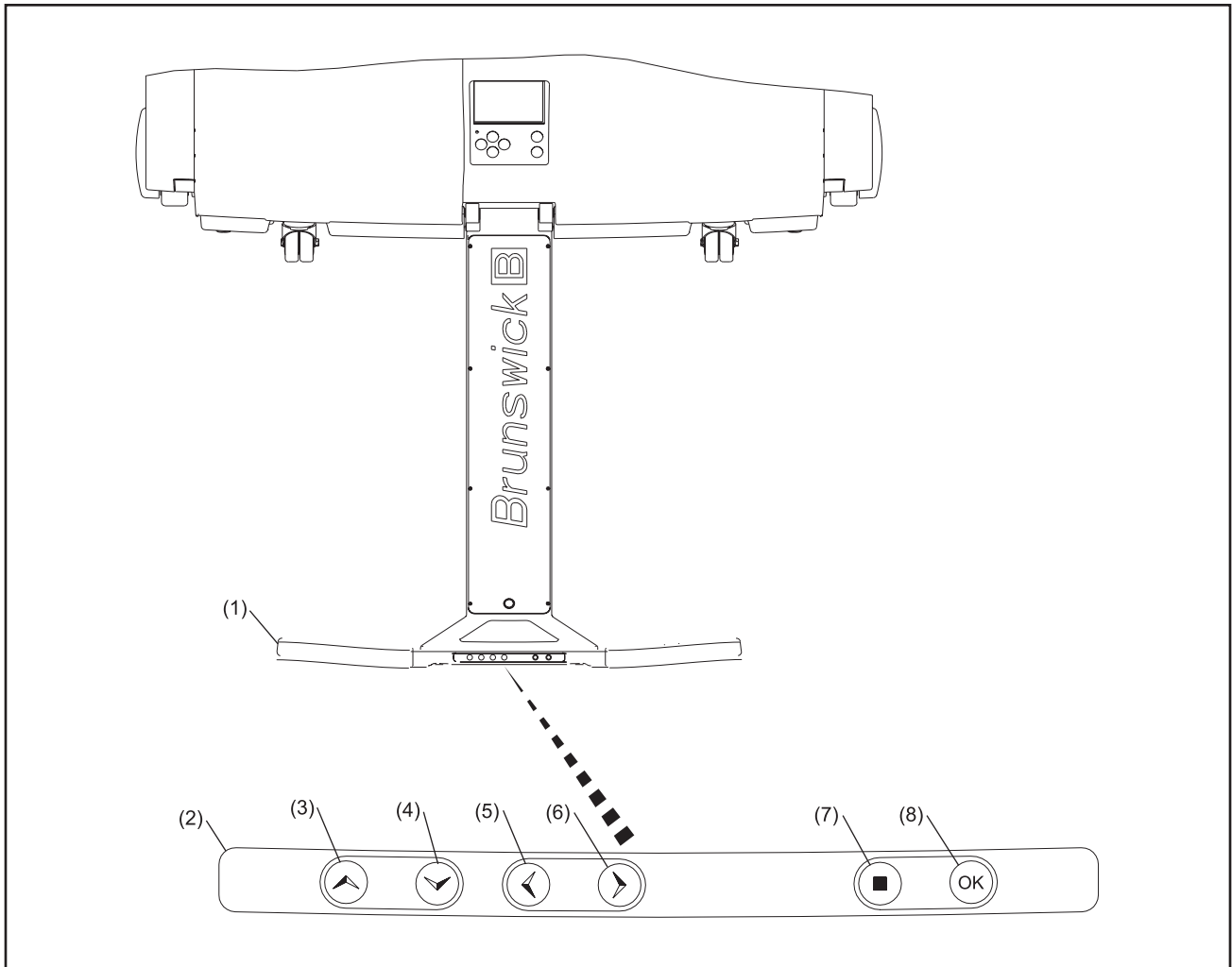

Figure 2-12. Handle Controls

- | | | |
|-----------------------|-----------------------|------------------------|
| (1) OPERATOR HANDLE | (2) HANDLE KEYPAD | (3) UP ARROW BUTTON |
| (4) DOWN ARROW BUTTON | (5) LEFT ARROW BUTTON | (6) RIGHT ARROW BUTTON |
| (7) EXIT BUTTON | (8) OK BUTTON | |

Section 3: Operating the Machine

Ready to get to work? Here's what you need to know to start, stop, and run the machine for normal, daily use. If you want detailed information about the sequence of operations, or to find out more about what's happening within the machine at each stage, see Sequence of Operations portion of **Section 6: Troubleshooting**.

In this section you will find:

1. What to know before you get started
2. Start-up procedure
3. Shutdown procedure
4. Storing the machine

Before You Supply Power

Step 1: Check tanks and duster cloth supply roll to be sure the machine is ready to operate.

1. Make sure **cleaner and conditioner supply tanks** are properly filled and caps are properly tightened.
2. Make sure the waste recovery tank is empty. If not, remove the waste tank from the machine and dispose of the used lane machine waste properly. Do NOT dump recovery tank in a septic tank or sanitary sewer system. Follow your local environmental regulations for the best method of disposal.
3. Make sure there is enough cloth on the **duster cloth supply roll** to complete the number of lanes desired.



CAUTION!

Fill and empty tanks with the machine in operating position (See "Finding Your Way Around the Authority22) and away from lanes and approaches. Use the no-spill containers to avoid spilling. Clean all spills and drips immediately.

Step 2: Position the machine on the approach.

1. With the machine in operating position, roll the machine to the first lane, about 2 feet away from the foul line.
2. Align the center mark on the machine with the center board of the lane.

Start-Up Procedure

Step 1: Supply power

1. Plug one end of cord into the machine and the other end into the wall outlet (115-volt, 50/60HZ, 20 amp outlet or 230-volt, 50HZ, 15 amp outlet).



NOTE:

If the GUI doesn't power up, check the main switch on the electronic enclosure, also rotate the emergency shut off switch clockwise 1/4 turn and release.

2. Place power cord ring into the cord kill assembly.



NOTE:

The cord should follow machine from lane to lane to avoid interference.

3. The display screen displays “READY” in the lower, right box on the screen.

Step 2: Press “OK” to prepare the machine to run.



NOTE:

During first usage you are required to download a pattern if you change the pattern or change the selected conditioner

1. The machine lowers the duster contact roller and squeegee into operating position, turns on the vacuum motor and pressurizes the conditioning system.



NOTE:

After the first lane, machine will pressurize the conditioning system when the reverse pass is completed.

2. The display screen displays “Put the lane machine on the lane” when the machine is ready to begin operation.
3. Position the machine on the lane with the larger rear wheels aligned with the gutter just in front of the foul line. Use the handle magnetic catch to center the machine onto the lane.

Step 3: Press “OK” a second time to begin operation on first lane.

1. The machine accelerates forward automatically cleaning and conditioning the lane until it reaches the pin deck.
 - a. For a detailed look at these operations, see Basic Operations, in the **Getting to know the Authority22** section.
2. When the machine reaches the end of the pin deck, it reverses direction and returns to the foul line completing conditioning operation.
3. The GUI displays the number of the next lane to be cleaned and conditioned.



CAUTION!

Manage the power cord so it does not get trapped under the lane machine. Replace the protective sleeve and heat shrink tubing on the power cord if they become damaged.

Step 4: Move machine to subsequent lanes.

1. When the lane is completed, pull the machine back about 2 feet from the foul line.
2. Turn machine and use the front lane to lane wheels to steer it to the next lane. Press “OK” to prepare the machine to run and wait for the display screen to prompt “Put the lane machine on the lane.”
3. Position the larger rear wheels so they align with the gutter just in front of the foul line of the next lane.
4. Press “OK” to begin operation on the lane.
5. Continue same procedure on subsequent lanes.

Shutting Down

Step 1: Pull machine off of the lane and onto approach.

Step 2: Empty the waste recovery tank. This will allow time for the machine to depressurize the conditioning system. Remove the waste tank from the machine and dispose of the used lane machine waste properly. Do NOT dump recovery tank in a septic tank or sanitary sewer system. Follow your local environmental regulations for the best method of disposal.

Step 3: Remove power cord from machine and unplug cord at receptacle, this will shut down the graphical user interface (the LED will continue to blink as long as the short term memory is active).



CAUTION!

Never raise the machine into transport position until you have emptied the waste recovery tank. Remove the waste tank from the machine and dispose of the used lane machine waste properly. Do NOT dump recovery tank in a septic tank or sanitary sewer system. Follow your local environmental regulations for the best method of disposal..



WARNING!

Always disconnect the power cord from the back of the machine before placing the machine in transport position.

Storing the Machine



WARNING!

Brunswick recommends using a partner whenever possible to help with lifting or lowering the machine from the operating position. Take care when lowering this machine into the operating position. Use proper lifting and lowering techniques, bend at the knees, and use a back support, if needed.

Step 1: Stand machine upright onto its transport casters.

Step 2: Wrap power cord in large loops for storage.

Step 3: Perform all daily maintenance tasks. See the **Maintenance & Service Section** for more information.

Step 4: Store machine in secure, warm location.

Intentionally Blank Page

Section 4: Using the Graphical User Interface (GUI)

The Graphical User Interface (GUI) is powerful, yet intuitive and easy to use and understand. This section gives you a tour of the four primary menus of the GUI and provides step-by-step instructions for customizing the machine's operations in each of those areas.

In this section you will find:

1. An introduction to the GUI
2. The operator screen
3. The pattern menu
4. The system menu
5. The maintenance menu

Introduction to the Graphical User Interface (GUI)

The Graphical User Interface (GUI) is the interface between the user and the machine's computer control system. The GUI monitors the machine's operation, tells you when you need to replace or repair parts, and lets you customize just about every aspect of operation to the needs of your bowling center or the preferences of your bowlers.



NOTE:

"Oil" is used interchangeably with "conditioner" on the GUI display screen.

The Elements of Most Display Screens

Most display screens have an upper menu bar that shows the four main content areas, a left-hand menu bar that lets you choose options within those four main screens and below the screen are the navigation buttons. A lower task bar also guides you in navigation, with the current date, time and status displayed at the bottom of the screen. Refer to Figure 4-1.

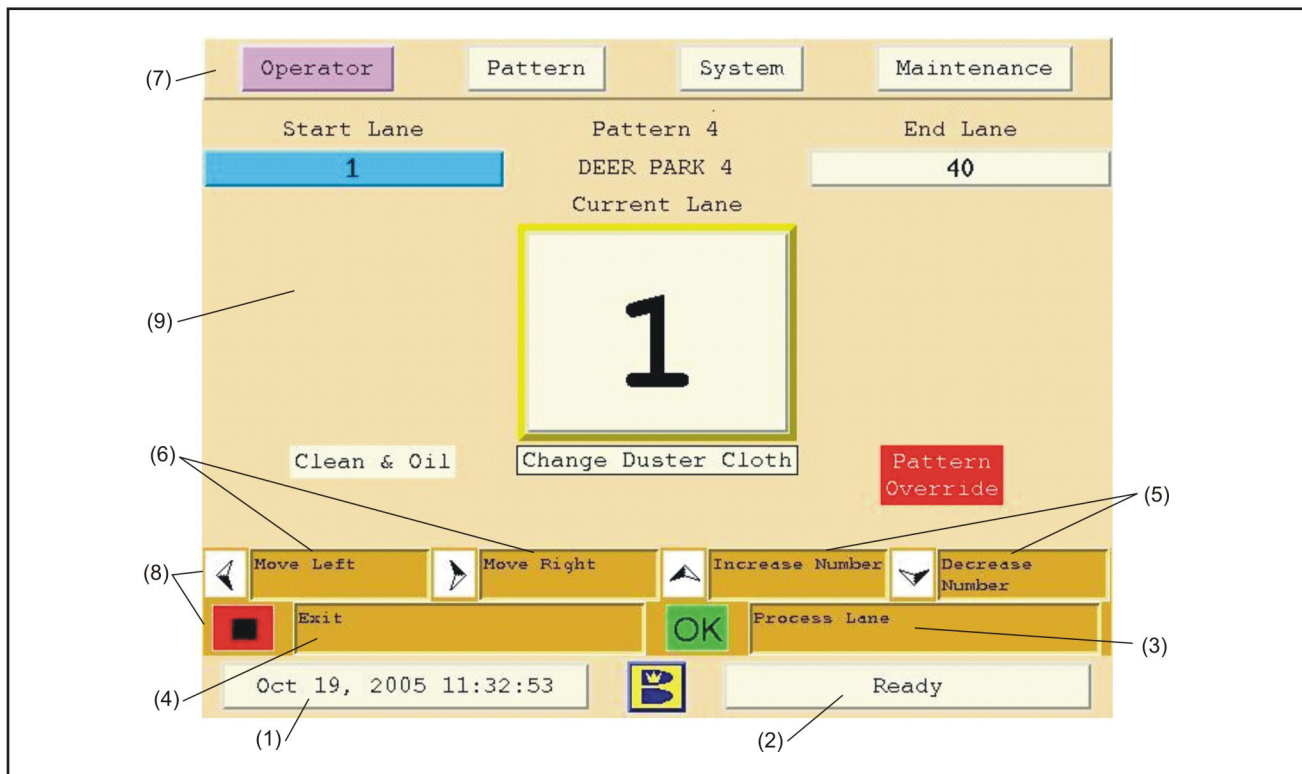

Figure 4-1. Screen Elements

- (1) DATE AND TIME
- (2) CURRENT STATUS
- (3) OK = ENTER OR ACCEPT
- (4) EXIT = BACK OR ESCAPE
- (5) UP/DOWN ARROWS = MOVE UP OR DOWN, AND INCREASE OR DECREASE ITEM VALUE
- (6) LEFT/RIGHT ARROWS = MOVE LEFT OR RIGHT
- (7) UPPER MENU BAR
- (8) LOWER TASK BARS = CUES TO NAVIGATION
- (9) ACTIVE AREA

How to Navigate

Left/right arrow buttons let you move around between areas on the screen or select information in a content area.



Up/down arrow buttons let you move up or down or increase or decrease the value in an active box.

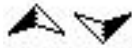

The “OK” button works like an “enter” or “return” button – it accepts, or says “yes,” to a selection.



The “Exit” button works like a “back” or “escape” button – taking you back to the previous screen. When you press “exit”, the GUI saves all changes made to that screen before exiting.



To Navigate Between the Four Main Menus

1. Press the “Exit” button until you reach the main screen (on this screen, the active area will be blank and only the upper menu bar with the names of the four main screens will be visible).
2. Use the left/right arrow buttons to select a screen from the upper menu bar. Then select that menu using the “OK” button.

To Navigate Between Choices in the Left Navigation Bar

1. Press the “Exit” button until you reach the main screen for that section –Operator, Pattern, System, or Maintenance (the active area of the screen will be blank and only the left menu bar will be visible). Refer to Figure 4-4.
2. Select a new choice in the left navigation bar using the up/down arrow buttons. Then select that screen using the “OK” button.

What Else You Should Know

Handle Controls

A secondary keypad on the machine's handle lets you control the machine from an upright position as you work. Refer to Figure 4-2.

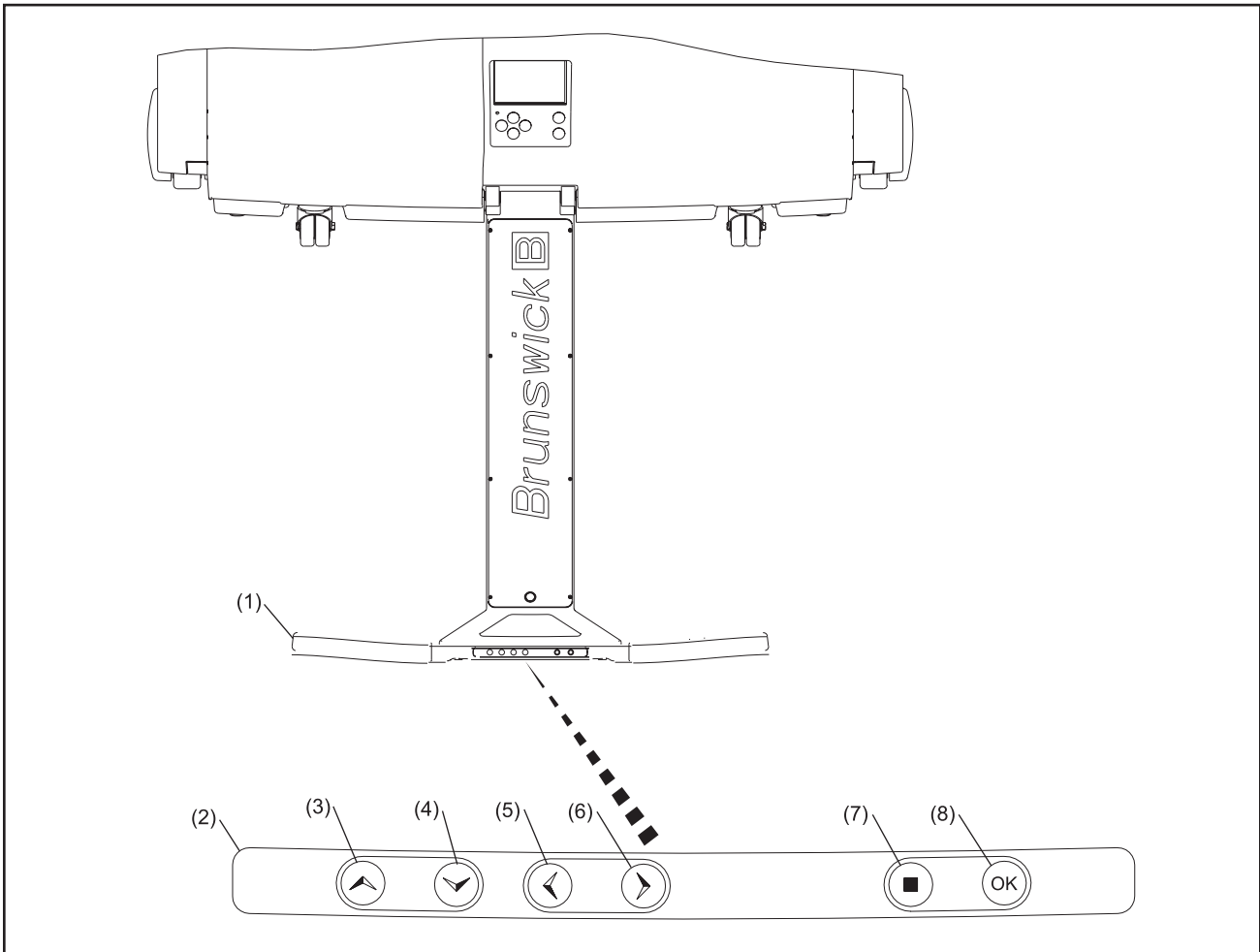

Figure 4-2. Handle Controls

- | | | |
|-----------------------|-----------------------|------------------------|
| (1) OPERATOR HANDLE | (2) HANDLE KEYPAD | (3) UP ARROW BUTTON |
| (4) DOWN ARROW BUTTON | (5) LEFT ARROW BUTTON | (6) RIGHT ARROW BUTTON |
| (7) EXIT BUTTON | (8) OK BUTTON | |

Screen Saver

A screen saver protects the screen against burn-in after the controller is inactive for about 20 minutes. Press “OK” to return to active screen.

Removable GUI

The Authority22 is supplied with a 12V DC power source so you can remove the GUI to change information, check counters, or design patterns from the comfort of your desk.

Security

Access to machine operations can be controlled by assigning Personal Identification Numbers (PINs) that prevent unauthorized access to the machine or its programs. Additionally, each user can be assigned one of two available levels of access based on their job function.

See the **Setting up PINs**, later in this section for more info on security levels and pin access.

Messages

Status messages: Status messages display in the lower right area of the control screen and remain visible on the screen until another status message is displayed. Status messages describe general information about the machine’s current and normal operations. Examples: *ready*, *running*.

Warning messages: Warning messages alert you to minor issues that need to be addressed. Example: *low cleaner fluid*.

Error messages: Error messages alert you to operational issues that need to be addressed. An error message will stop the machine from running until the problem has been corrected. Example: *Squeegee switch is not working properly*.

Maintenance messages: Maintenance messages are warning messages that tell you when a replaceable part has reached its useful life. Maintenance messages display during start-up. Maintenance messages will not prevent the machine from running. Example: *duster cloth needs to be replaced*.

The Operator Screen

This screen displays during the normal operation of the machine. As you work, it gives you general information about the current setup and operation. When an area is highlighted in blue, that is an indication the area can be changed. Refer to Figure 4-3.



NOTE:

This screen may be PIN protected.

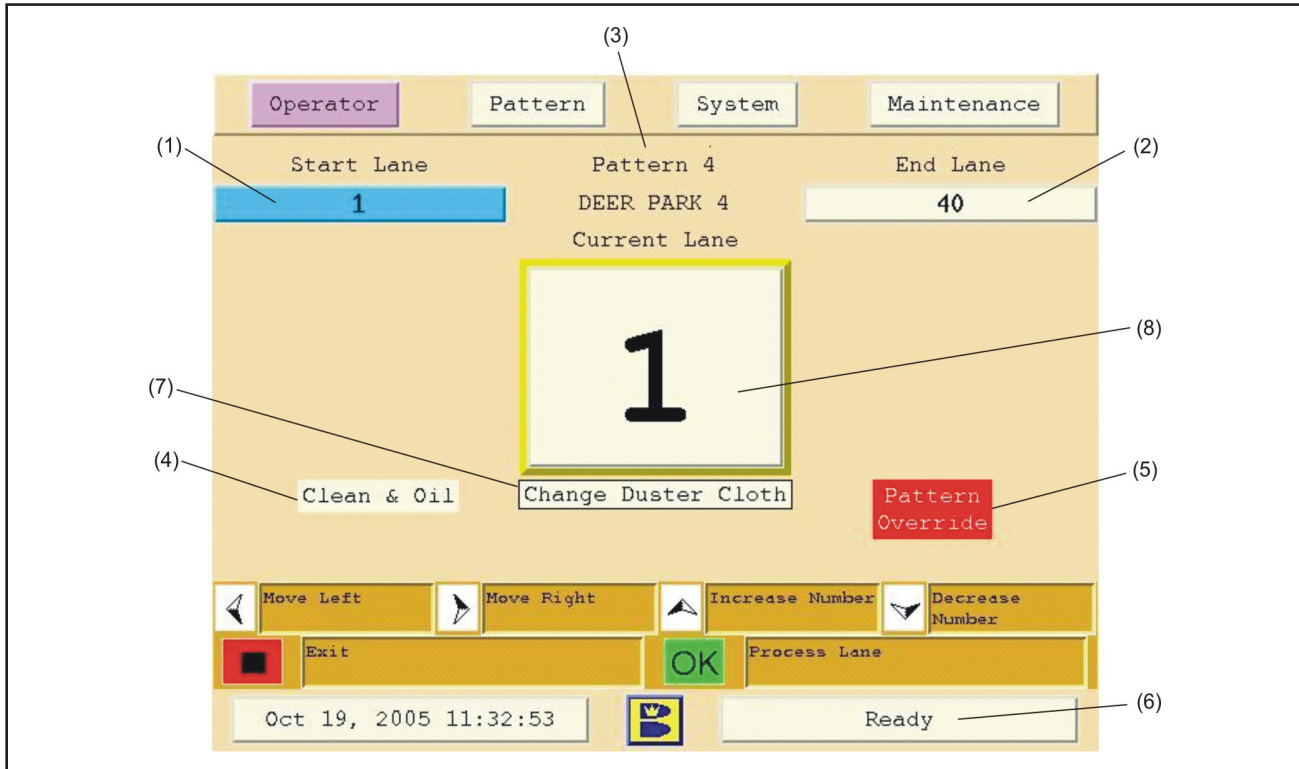

Figure 4-3. Operator Screen

- (1) START LANE
- (2) END LANE
- (3) CURRENT PATTERN
- (4) THE OPERATION (MODE)
- (5) PATTERN OVERRIDE NOTICE – APPEARS WHEN RUNNING PATTERN OTHER THAN THE SCHEDULED PATTERN
- (6) STATUS MESSAGE
- (7) DUSTER MAINTENANCE BUTTON – ALLOWS CLOTH REPLACEMENT FROM OPERATOR'S SCREEN
- (8) CURRENT LANE

Changing the Start Lane

1. Go to the Operator screen.
2. Use the left/right arrows to navigate to “Start Lane”.
3. Use the up/down arrows to change the number of the start lane for this session.



NOTE:

When you exit the operator screen, the lane machine will return to its default “start lane” settings.

Changing the End Lane

1. Go to the Operator screen.
2. Use the left/right arrows to navigate to “End Lane”.
3. Use the up/down arrows to change the number of the end lane for this session.



NOTE:

When you exit the operator screen, the lane machine will return to its default “end lane” settings.

Skipping or Repeating Lanes

If you want to skip or repeat lanes during a session, you must change the “Current Lane” so the machine can maintain your place in the process. If you skip lanes, the GUI will direct you to return to the closest lane once you’ve completed the last lane in the normal sequence (the end lane).

1. Go to the Operator screen.
2. Use the left/right arrows to navigate to the “Current Lane”.
3. Use the up/down arrows to change the number of the lane you are currently on.

The Pattern Screen



NOTE:

This screen may be PIN protected.

The pattern screen lets you select, change, design, or override a lane conditioning pattern. The Authority22 comes pre-programmed with 10 conditioning patterns. You may use these patterns as your own, or use them as templates to create customized patterns – just find the pattern that’s closest to what you want and then adjust the zone lengths and oil volumes. You can return to the original default patterns at any time. Refer to Figure 4-4.

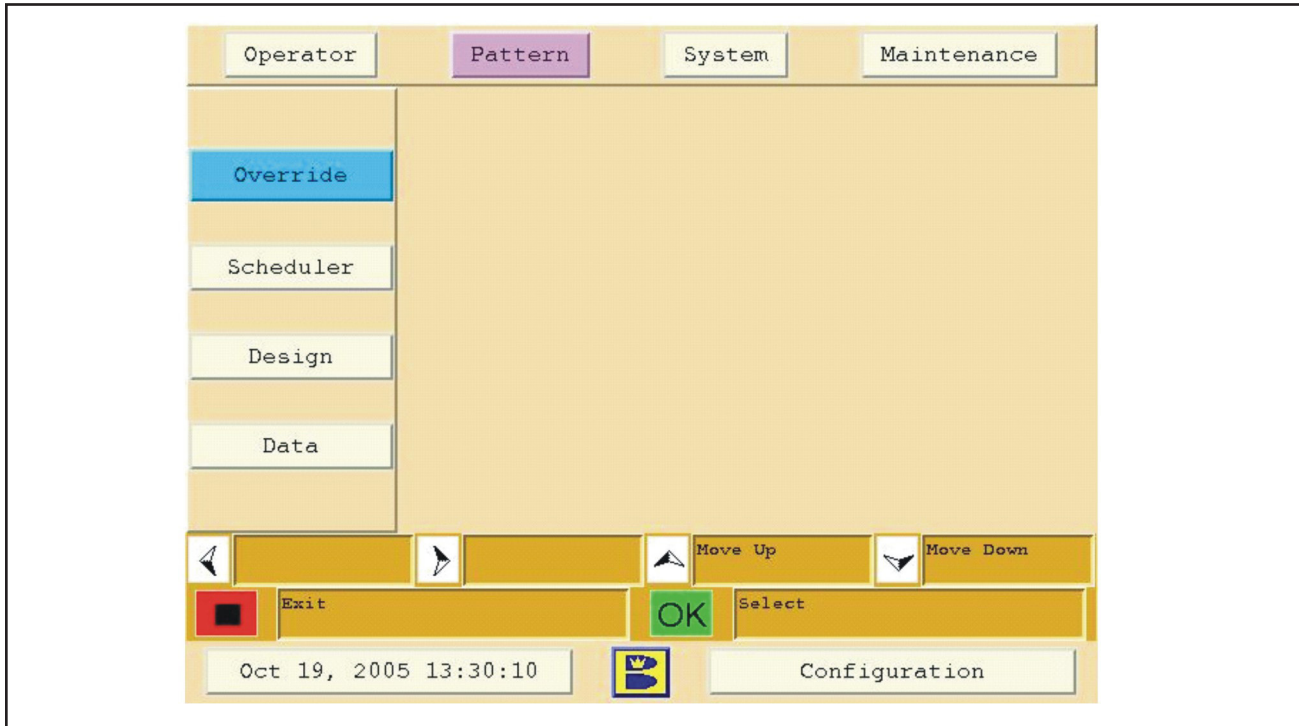

Figure 4-4. Pattern Screen

Override lets you override the scheduled conditioning pattern and select another programmed pattern for this session.

Scheduler lets you program the machine to automatically use different conditioning patterns on different days of the week, times of day, or both. The scheduler will also allow you to run different conditioner patterns on specific lanes within those days or times of day.

Design lets you change the patterns and customize the type of operation, speed of travel, distances at which to start different operations, and whether to split the cleaning and conditioning operations.

Data lets you save your custom patterns, restore previously saved patterns, or restore default patterns.

Pattern Override

The Pattern Override enables the user to select and run a conditioner pattern that is different than scheduled pattern. When the system security feature is used, level 1 and level 2 users are able to access this option, a PIN number may be required for access. Each pattern override is recorded in the “Pattern Run Log” in the “Maintenance” menu under “Logs”. Refer to Figure 4-5.

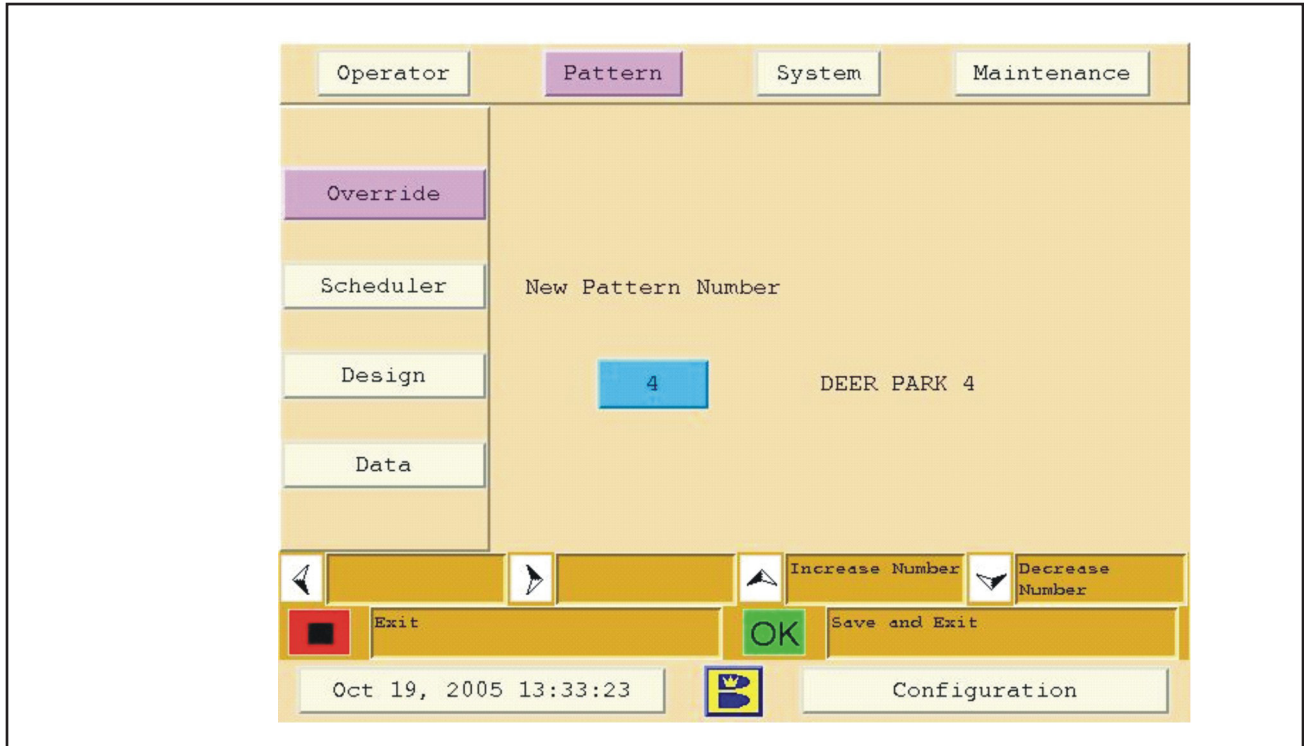

Figure 4-5. Pattern Override

Overriding the Conditioning Pattern

1. Go to the Pattern menu.
2. Select “Override”. Press “OK”.
3. Use up/down arrows to select a new pattern number.
4. Press OK.



NOTE:

After you press “OK”, the GUI will return to the operator screen to begin running the new pattern and “Pattern Override” will display next to the current lane.



NOTE:

If EXIT is pressed while in the Pattern Override screen, the selected override will not be saved.



NOTE:

The override pattern remains active until you exit the operator screen.

Pattern Scheduler

Lets you schedule different conditioning patterns for up to 3 time periods per day, 7 days per week, and for up to 5 different ranges of lanes to accommodate different types of bowlers and leagues. Refer to Figure 4-6.



NOTE:

This screen may be PIN protected.



NOTE:

Make sure that a certified Brunswick installer has set up the number of lanes in your center from the system menu before you start setting up your Pattern Scheduler (page 53).

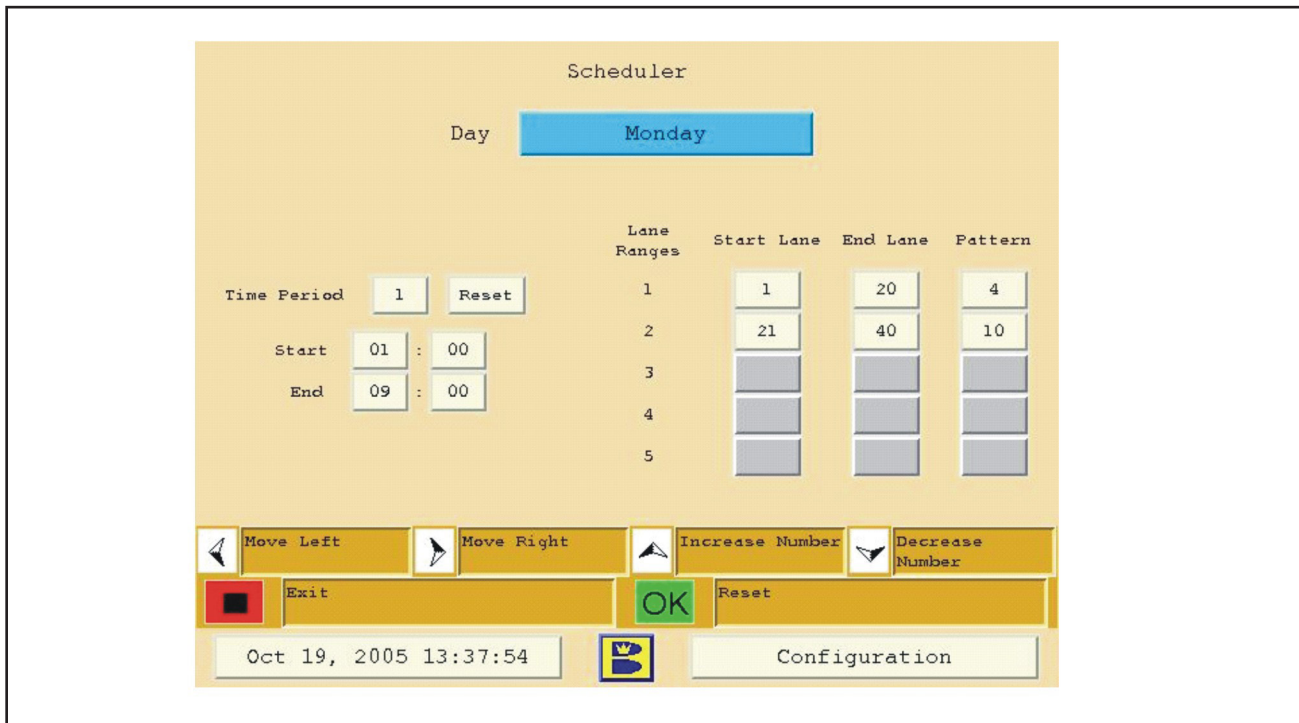

Figure 4-6. Pattern Scheduler

Setting up a Cleaning/Conditioning Schedule that Varies by Time, Day or Lane Number

1. Go to the Pattern menu.
2. Use the up/down arrows to navigate to “Scheduler”. Press “OK”.
3. Select the day of the week.
 - a. Use the right/left arrows to navigate to the day of the week.
 - b. Use the up/down arrow to select the day of the week.

4. Select a time period (up to 3 time periods per day).
 - a. To use the same pattern all day, use the default settings:
 - 1) Time period = 1
 - 2) Start time is 1:00, end time is 23:59
 - b. To use different patterns during different times of the day, enter start and end times for up to 3 time periods per day.
5. Select lane ranges & patterns.
 - a. To use the same pattern on all lanes, use the default setting:
 - 1) Lane range = 1
 - 2) Start lane is 1, end lane is 40 (total number of lanes in center)
6. Select a pattern for that range.
 - a. To use different patterns on different lanes:
 - 1) Select the start and end lane for up to 5 lane ranges.
 - 2) Select a pattern for each lane range.
7. Press “exit” to save and return to the previous screen.



NOTE:

If any day or time period is left without a scheduled pattern, all lanes will run on the default pattern (pattern 1). Please check to make sure that you have not allowed time gaps between any of the 3 allowable time periods. These gaps could result in an unexpected pattern selection if the lane machine is in operation during that time gap.

Pattern Design

This menu allows you to program custom information for each conditioning pattern, including pattern shape and volume.

The first screen in your Pattern Design menu is the Pattern Parameters screen. This screen allows you to customize specific functions and modes for each of the 10 patterns. Refer to Figure 4-7.



NOTE:

This screen may be PIN protected.

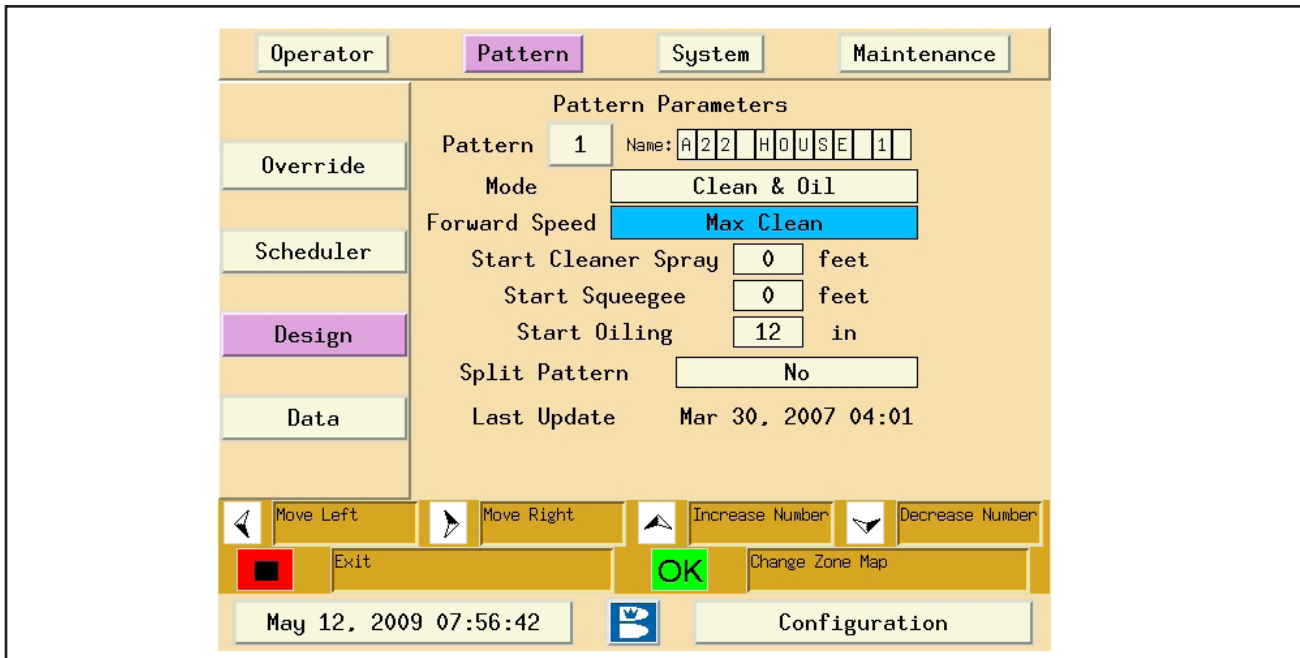

Figure 4-7. Pattern Design

Pattern Number and Name

You can select one of 10 preset patterns or customize any pattern to perform based on your bowlers needs. You can also assign a name to each pattern making it easier to keep track and identify.

Changing the Pattern Name or Number

1. Go to the Pattern menu.
2. Select “Design” & press “OK”.
3. Use the up/down arrows to select the pattern number.
4. Use the left/right arrows to select the pattern name.
5. Use the up/down arrows to change the pattern name.
6. Press “exit” to save and return to the previous screen.

Mode

The mode allows you to select the type of operation you wish to perform for that pattern. You can select between clean and oil, clean only, and oil only. The clean and oil mode cleans and condition the lanes in one forward and reverse run. The clean only mode uses only the cleaning system, and the oil only mode will only apply conditioner. To separate the clean and condition mode into a two-run operation refer to “Split Pattern” later in this section.

Changing the Mode of Operation

1. Go to the Pattern menu.
2. Select “Design” & press “OK”.
3. Use the left/right arrows to navigate to “Mode”.
4. Use the up/down arrows to select:
 - a. Clean & Oil
 - b. Oil
 - c. Clean
5. Press “exit” to save and return to the previous screen.

Forward Speed

The Authority 22 offers you two choices of travel speeds: “Quick Clean” and “Max Clean”. In most instances the machine will operate in “Max Clean” (~21 inches per second). The “Quick Clean” speed (~27 inches per second) reduces the cleaning time to allow for centers using lighter volumes of conditioner.

Changing the Machine’s Operating Speed

1. Go to the Pattern menu.
2. Select “Design” & press “OK”.
3. Use the left/right arrows to navigate to “Travel Speed”.
4. Use the up/down arrows to select.
 - a. Max Clean
 - b. Quick Clean
5. Press “exit” to save and return to the previous screen.

Start Cleaner Spray

This option allows you to set a distance down the lane, in feet, to start spraying cleaner. It is designed for use on patterns that require the back end of the lane to be cleaned without cleaning the entire lane. We also recommend using this option if you have wood lanes and the head (maple) section has feathering (splintering between boards) or board separation. Software prevents your start cleaner spray distance from being shorter than the start squeegee distance.

Changing the Distance from the Foul Line at which Cleaning Starts

1. Go to the Pattern menu.
2. Select “Design” & press “OK”.
3. Use the left/right arrows to navigate to “Start Cleaner Spray”.
4. Use the up/down arrows to select number of feet from the foul line you want to start cleaning.



NOTE:

Default setting is 0. Select any distance up to 57 feet. The default setting, allows the machine to spray a single pulse of cleaner as soon as the duster cloth contacts the lane surface. Values above zero will start to spray at that selected distance.

5. Press “exit” to save and return to the previous screen.

Start Squeegee

The start squeegee option is the counter part to the start cleaner spray option when used for cleaning the back end of the lane. It also allows you to “dry” squeegee the conditioner from old wood lanes showing feathering or board separation leaving a thin film of oil that will help protect the wood surface. Measured in feet, this option may be turned on before the cleaner spray starts, but not afterward.

Changing the Distance from the Foul Line at which the Squeegee Starts

1. Go to the Pattern menu.
2. Select “Design” & press “OK”.
3. Use the left/right arrows to navigate to “Start Squeegee”.
4. Use the up/down arrows to select the number of feet from the foul line you want to start the squeegee.



NOTE:

Default setting is 0. Select any distance up to 57 feet. The number must be less than or equal to the “start Cleaner Spray” distance.

5. Press “exit” to save and return to the previous screen.

Start Oiling

This option is used as a safety feature on the lane machine. Select a start distance from the foul line to start conditioning, in 6 inch increments up to 24 inches. This prevents any applying or buffing of oil within that distance from the foul line, leaving it clean so recreational bowlers have less tendency to track oil onto the approaches. A level 2 security ID will allow you to set the minimum distance in the System Settings menu.

Changing the Distance from the Foul Line at which Conditioning Starts

1. Go to the Pattern menu.
2. Select “Design” & press “OK”.
3. Use the left/right arrows to navigate to “Start Oiling”.
4. Use the up/down arrows to select the number of inches from the foul line you want to start the conditioning operation.



NOTE:

Default setting is 6". Select between 6", 12", 18" and 24".

5. Press “exit” to save and return to the previous screen

Split Pattern

The split pattern option enables the user to separate the “clean & oil” mode into two separate runs of the machine performed on the same lane. By selecting “Yes” the machine will travel down the lane performing the cleaning operation and return to the foul line. Then by the user’s action, the machine will travel down the lane performing the conditioning operation and also buffing the pattern on the reverse. When “No” is selected the machine will clean and condition the lanes in one operation.

Splitting the Pattern to Separate Cleaning and Conditioning Functions

1. Go to the Pattern menu.
2. Select “Design” & press “OK”.
3. Use the left/right arrows to navigate to “Split Pattern”.
4. Use the up/down arrows to select yes to separate the cleaning and conditioning patterns into two operations.
5. Press “exit” to save and return to the previous screen.

Last Update

The last update is a feature that allows you to see if and when a conditioning pattern was last modified. This proves helpful when trying to troubleshoot the pattern or if the pattern was suspect to an unauthorized modification. The “Pattern change log” stores each time the pattern or its parameters are modified.

Checking the Date and Time a Pattern was Updated

1. Go to the Pattern menu.
2. Select “Design” & press “OK”.
3. Use the up/down arrows to select the number of the pattern you are checking on.
4. See “Last Update” at the bottom of the active area of the screen.
5. Press “exit” to return to the previous screen.

Additional Pattern Design Screens

Two additional screens may be accessed in the pattern parameters screen. These additional screens are the *Zone Configuration* screen and the *Oil Levels* screen. Please observe the following steps to gain access to both of these design screens.



NOTE:

Changes made to the Zone Configuration screen or the Oil Level screen will require a new download of the pattern to the machine control board.

Creating or Changing a Conditioning Pattern

1. Go to the Pattern menu.
2. Select “Design” & press “OK”.
3. Use the up/down arrows to select the number of the pattern you want to modify.
4. Press “OK” to go to the Zone Configuration screen, details follow.

Zone Configuration Screen

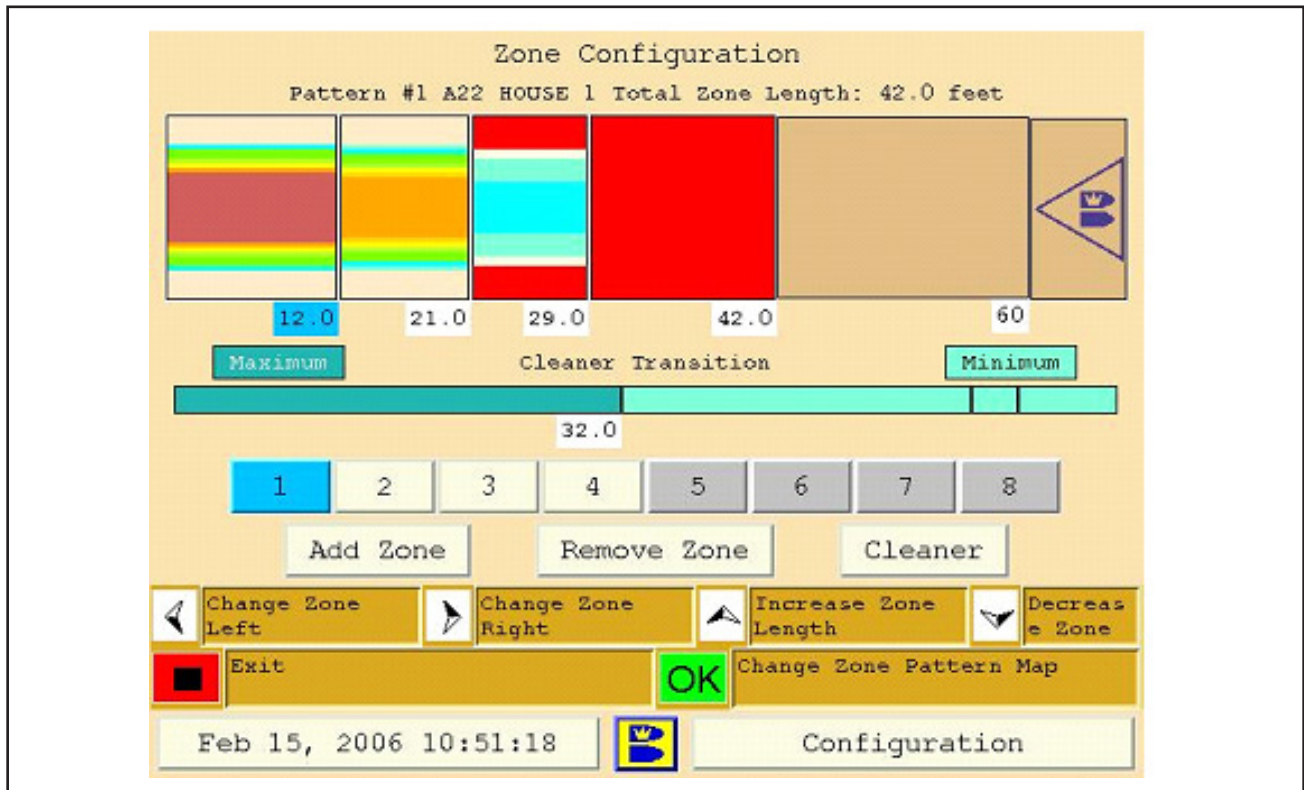

Figure 4-8. Zone Configuration

The Zone Configuration screen shows conditioner patterns graphically to make it easy to visualize and change the zones and the oil volumes.

You can create anywhere from 1 to 8 zones in a pattern. A zone can be between 3 and 57 feet long and can be adjusted in increments of .5 feet. The Zone Configuration screen displays the length of each zone and the distance to the end of the zone from the foul line. Within each zone, oil levels for each board are shown and screen colors are based on oil volumes selected. Refer to Figure 4-8.

Modifying a zone

1. Use the left and right arrow to navigate to the zone number you wish to modify.
2. Use the up and down arrows to increase or decrease the length of the zone.
3. After making the modification you may choose another zone to modify, or press "OK" to enter the "Oil Levels," or you may "Exit" to save the changes.



NOTE:

The GUI will prompt you to download the pattern to the machine control board after you exit the zone configuration screen. Press "OK" to start the download or "Exit" to download at a later time.

Adding a zone

1. Use the left and right arrow to navigate to the “Add Zone” button.
2. Press “OK” and a new zone will appear at the end of the last zone in the pattern.
3. Use the up and down arrows to adjust the length of the new zone.

Removing a zone

1. Use the left and right arrow to navigate to the “Remove Zone” button.
2. Press “OK” and the zone closest to the pindeck will be removed.
3. Use the up and down arrows to adjust the zones to desired distances.

Modifying the Cleaner Transition

The cleaner is applied in a continuous spray to the lane during the cleaning operation (except for a short pause of the cleaner spray at the transition distance). You can select the distance at which the cleaner spray transitions between Maximum and Minimum output. This lets you synchronize the cleaner volume with the conditioner pattern, using maximum volume for the front, thicker conditioner zone(s) and minimum volume for the back end and pin deck.

1. Use the right/left arrows to navigate to “Cleaner”.
2. Use the up/down arrows to increase or decrease the number of feet at which the cleaner volume transitions from Maximum to Minimum volume.
3. Press “exit” to save and return to the previous screen.

Oil Level Screen

The Oil Levels screens allow you to look at the shape of the pattern within a zone. You can make adjustments to individual boards or you may select a group of boards to adjust. This screen is accessed through the Zone Configuration screen in the Pattern design menu. Refer to Figure 4-9.

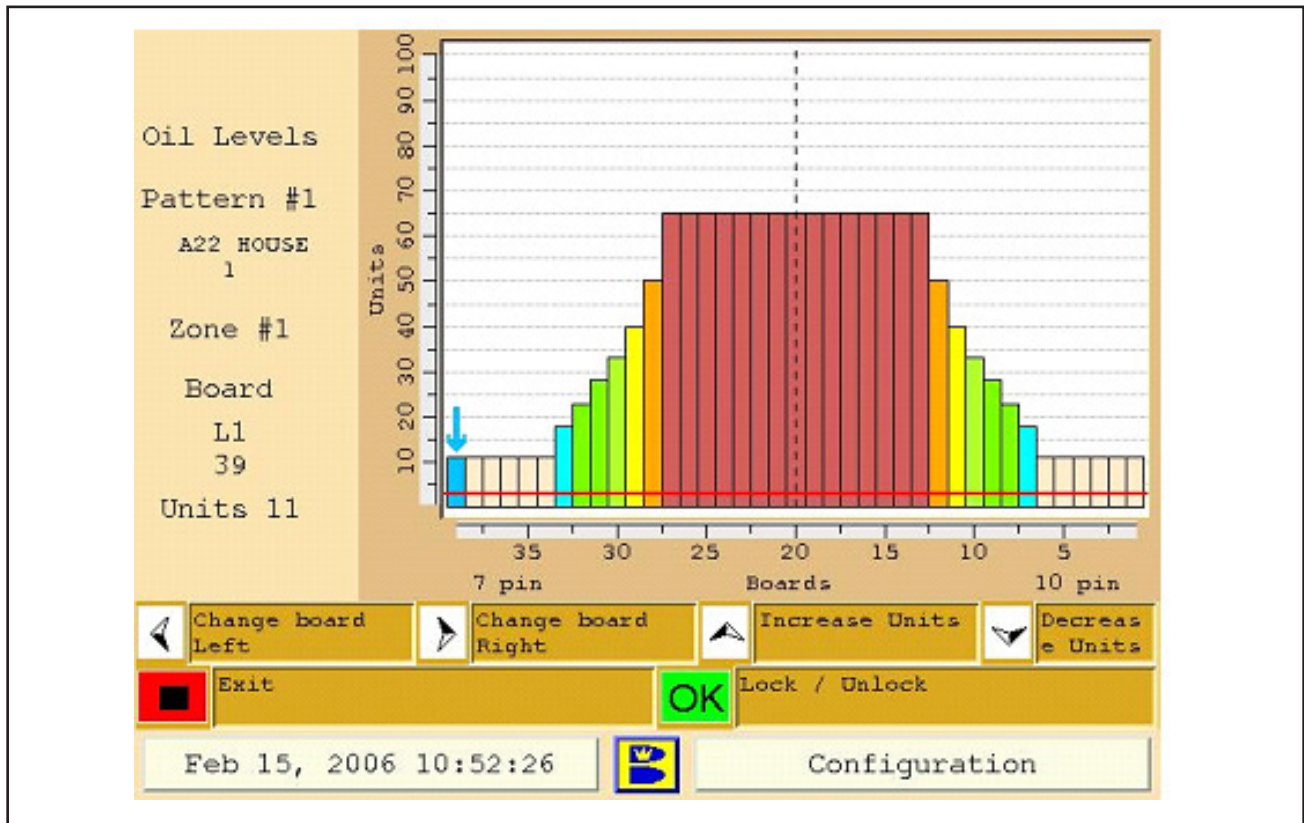

Figure 4-9. Oil Level

From the Zone Configuration screen, use the following steps to enter into the Oil Levels screen.



NOTE:

Changes made in the Oil Levels screen will require a new download of the pattern to the machine control board.

1. Use the left/right arrow to navigate to select the zone you want to adjust.
2. Press “OK” to go to the “Oil Levels” screen.



NOTE:

The Oil Levels screen lets you adjust the amount of oil applied to each of the 39 boards in each zone of your pattern. Oil levels are measured in “units of oil”, the USBC standard, and are adjustable in 1-unit increments. The USBC minimum oil volume of 3 units is shown as a red line on the oil levels graph.

3. Use the left/right arrows to select the board you want to adjust (numbered 1-39 from the right of the screen or L2 (left 2 board) to R2 (right 2 board)). Refer to Figure 4-10.

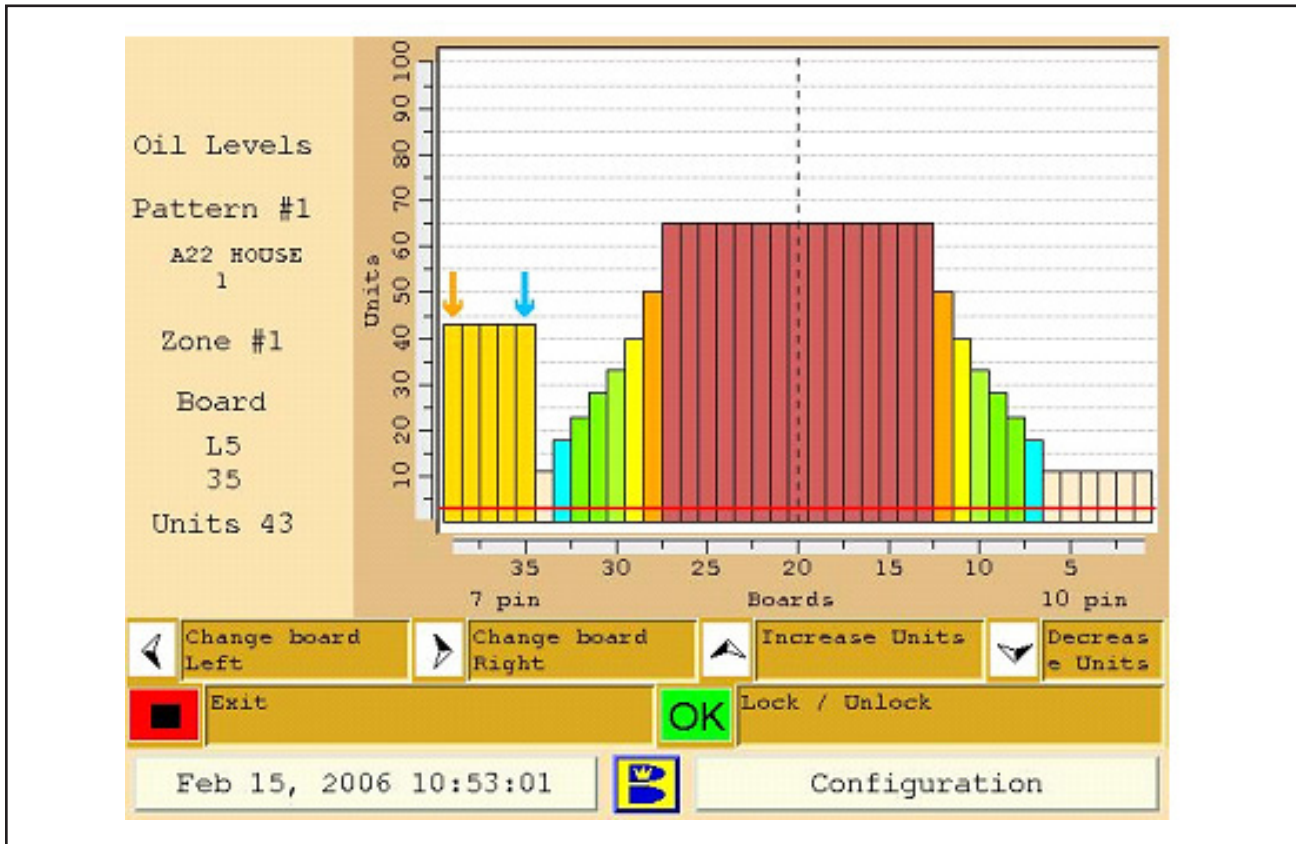

Figure 4-10. Oil Level

4. Use the up/down arrows to increase or decrease the amount of oil to be applied to a board. Continue on all boards, as needed.
 - a. To change oil levels for groups of boards:
 - 1) Use left/right arrows to select the first board in the group, press "OK".
 - 2) Use the left/right arrows to select the last board in the group (Do NOT press "OK" again).
 - 3) Use the up/down arrows to adjust oil volume.
 - 4) Press "OK" again to "unlock" the selected group of boards.
5. To adjust oil volume in other zones, Press "exit" to return to the previous screen and follow the same procedure for other zones.
6. Press "exit" to save and return to the previous screen.

Pattern Download

Each time a conditioner pattern is modified, the GUI is required to “download” the pattern data to the machine control board inside the electronic enclosure before that conditioner pattern can be run on any lane. The download message will appear when you “Exit” the “Zone Configuration” screen or if you are in the operator screen and a pattern has not been downloaded since it was last modified. Refer to Figure 4-11.



Figure 4-11. Pattern Download

The download time is approximately 4 minutes. A download progress bar will appear along with the pattern number and name. If necessary the download may be aborted by pressing “Exit”. Refer to Figure 4-12.



NOTE:

Any new or revised pattern must be downloaded from the GUI active memory to the machine control board to perform a conditioning run using that pattern. When the pattern is downloaded from the Operators screen the machine will prepare to run when the download is completed. The vacuum motor will run and the machine will instruct the operator to place the machine on the lane. Download from the Pattern Design Screen to avoid the vacuum motor turning on at the end of the downloads.

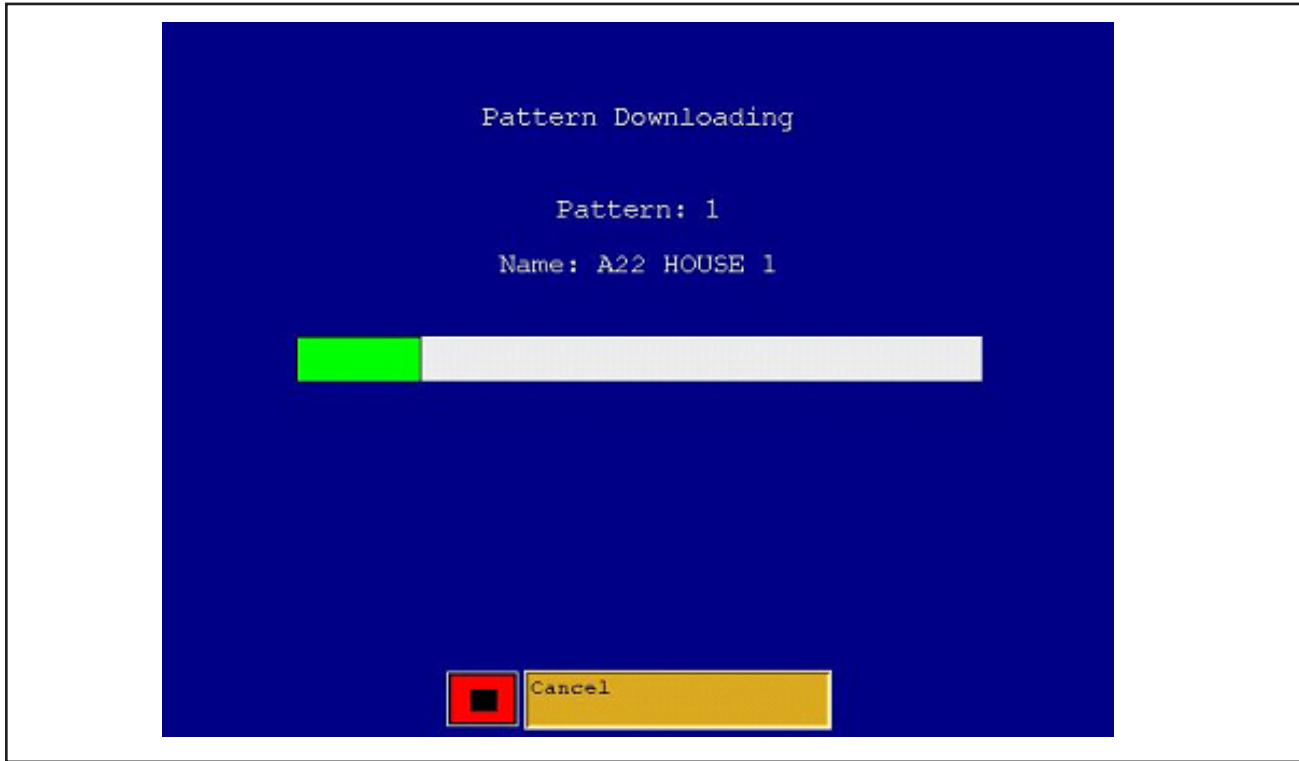

Figure 4-12. Download Progress



NOTE:

All patterns must be downloaded after changing to a different conditioner selection. To avoid unnecessary downloads, select your desired conditioner from the System menu before downloading patterns.

Patterns and Memory

Before explaining the Pattern Data options, it is important to define the different locations for the lane machine patterns and memory. Refer to figure P.

“Active GUI Memory” There are 10 patterns available in the Active GUI Memory that can be run or modified as explained in the pervious manual sections on the use of Pattern Screens.

“Machine Control PCB Memory” There are 10 pattern locations in the Machine Control PCB Memory that can individually be downloaded from the Active GUI Memory. Any individual pattern that has been downloaded into the Machine Control PCB Memory can be selected and run without delay. If a change is made on any pattern in the Active GUI Memory, it must be downloaded again before it can be run.

“GUI Back-Up Files” There are 5 Back-Up Files in the GUI memory, each containing 10 patterns that can be exchanged with the 10 patterns in the Active GUI Memory. The Save Pattern Data option can be used to copy the 10 patterns in Active GUI Memory into one of the 5 GUI Back-Up Files. The date and time that the 10 patterns were saved in the GUI Back-Up Files will be used as the file name. The Restore Pattern Data option can be used to move the 10 patterns from any of the 5 GUI Back-Up Files back to the Active GUI Memory. The Restore Default Data option can always be used to move the 10 original patterns at the time of the machine installation back into the Active GUI Memory. This will be explained in more detail in the “Pattern Data” section of this manual.

“USB Drive Files” There are five files in the USB Drive Memory, each containing 10 patterns that can be exchanged with the 10 patterns in the Active GUI Memory. To start this process, the USB flash drive should be inserted into the GUI USB port. The export option can be used to copy the 10 patterns in Active GUI Memory into one of the five USB Drive Files. The date and time that the 10 patterns in Active GUI Memory into one of the 5 USB Drive Files. The date and time that the 10 patters were saved in the USB Drive Files will be used as the file name. The import option can be used to more the 10 patterns from any of the five USB Drive Files back to the Active GUI Memory. This will be explained in the Importing/Exporting section of this manual.



NOTE:

You can NOT exchange any of the 5 files directly between the USB Drive Files and the GUI Backup Files. Only one file containing 10 patterns can be exchanged between the Active GUI Memory and the USB Drive Files or the GUI Backup Files. To move all five files between the USB Drive files and GUI Backup Files, you must first import/export or save/restore each file of 10 patterns with the Active GUI Memory. Refer to A22 PCB/GUI/USB Pattern Data Diagram on the following page.

Electronic Enclosure		GUI	
(Individual Downloaded Machine Patterns)	(10 Live GUI Patterns)		
"Machine Control PCB Memory"		"Active GUI Memory"	
Pattern Name, File # & Selected Conditioner	Pattern Name & File # Saved Date of File #		
Pattern #1 A22 House 1	Pattern #1 A22 House 1		
Pattern #2 Maple Lanes House	Pattern #2 Maple Lanes House		
Pattern #3 Maple Lanes House	Pattern #3 Maple Lanes League 1		
Pattern #4 Maple Lanes League 2	Pattern #4 Maple Lanes League 2		
Pattern #5 Competitive1	Pattern #5 Maple Lanes Youth		
Pattern #6 Competitive2	Pattern #6 Clean Only		
Pattern #7	Pattern #7 Maple Lanes Sport		
Pattern #8	Pattern #8 Sport 2'5-1		
Pattern #9	Pattern #9 Sport 2-1		
Pattern #10 Sport Flat	Pattern #10 Maple Lanes Flat		
Note: The lane machine can run any individual pattern that has been selected and downloaded from the Active GUI Memory to the Machine Control PCB Memory. There can be empty pattern numbers in the Machine Control PCB Memory without causing problems. The Machine Control PCB Memory can contain individual patterns from previous GUI Back-Up Files (Pattern #7 could be from GUI Back-Up File 3). If the Active GUI Memory Pattern #7 has different pattern parameters or conditioner selection, the new parameters would need to be downloaded before running pattern #7 or the Active GUI Memory would need to be switched to Back-Up File 3.)		USB Memory Stick - Flash Drive Only the selected File of 10 patterns is Imported or Exported between the "USB Drive Files" and the "10 Live GUI Files"	
		"USB Drive Files" (Pattern Data in USB Memory Stick available to Import/Export) Backup 1 Backup 2 Backup 3 Backup 4 Backup 5 Oct 7, 2007 ABC House A22 House 2 Tournament ABC Open Test Shot Top Hat ABC Sport Sport 2-1 Clean Only ABC Flat	
		"GUI Back Up Files" (Available GUI Memory to <Restore to or >Save Data from Active Memory) Backup 1 Backup 2 Backup 3 Backup 4 Backup 5 Mar 3, 2008 A22 House 1 Maple House Ladies & Sr Open Play Maple Youth Clean Only Maple Sport Sport 2'5-1 Sport 2-1 Sport Flat	

A22 PCB/GUI/USB Pattern Data Diagram

Pattern Data This screen allows the user to save pattern data, restore default data, and restore saved conditioner pattern data within the GUI memory. The GUI can store 50 patterns, 10 patterns in each backup file. Each file will display a date and time if already used. Refer to Figure 4-13.

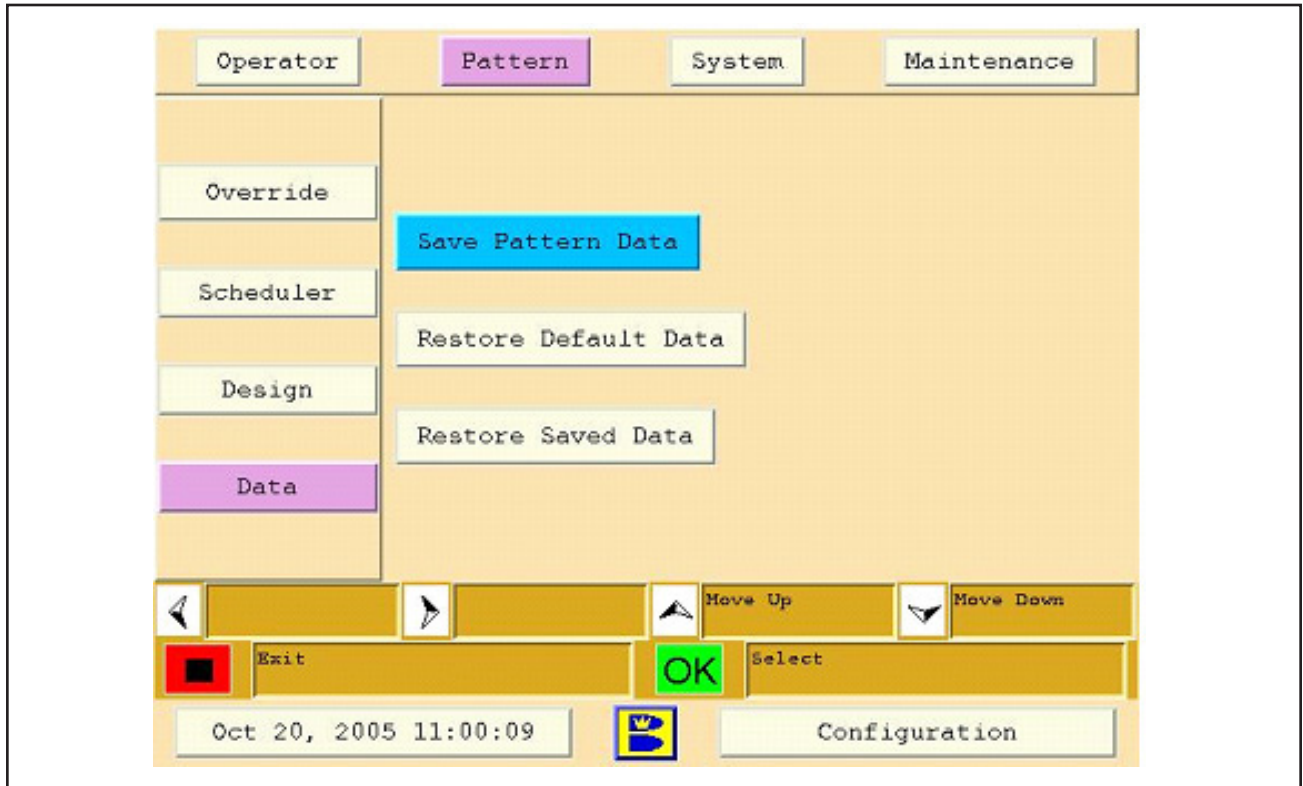

Figure 4-13. Pattern Data

Steps for saving, restoring default, and restoring saved data:

1. Go to the Pattern menu and press “OK”.
2. Use the up/down arrows and select Data by pressing “OK”.
3. Select the option you wish to perform by navigating with the up/down arrows and press “OK” and the following screen will appear. Refer to Figure 4-14.



NOTE:

The backup screen will not appear when restoring the default patterns. Only the 10 patterns in the active GUI memory are saved when you select the “Save Pattern Data” option. These 10 patterns are saved in the GUI backup memory in any of the five available backup folders with the date and time that the file was saved. A backup folder without a date is an empty folder. Saving to a folder with an existing date/time will replace the pattern date with the current date/time and active GUI memory patterns.

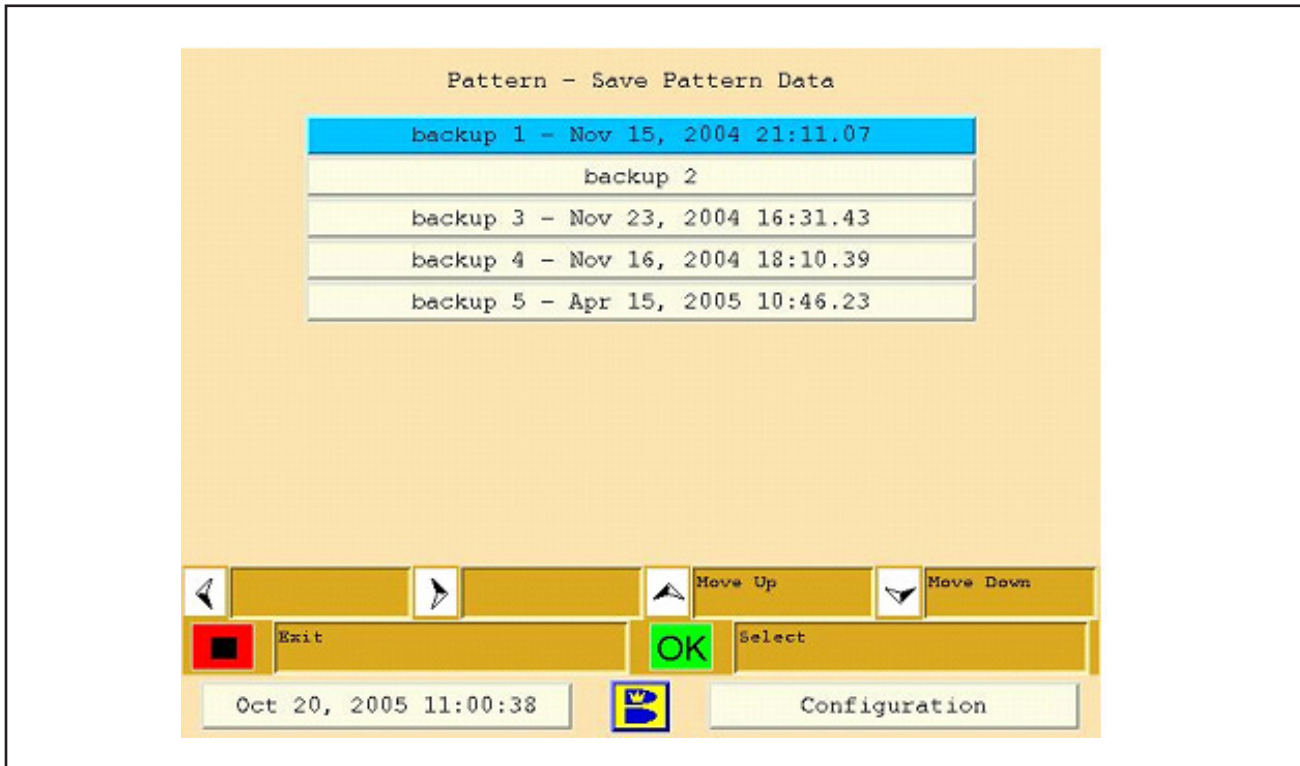

Figure 4-14. Save Pattern Data

- For saving data or restoring saved data you may select one of the five available backup folders and press "OK".



NOTE:

Backup files may be over written when saving pattern data. Be sure that the data is saved to a file that is not used or saved to a file in which you no longer need the previously saved data.



NOTE:

Pattern data can be backed up and imported to a USB flash drive as explained earlier in "Backing Up and Importing Data" in Section 4. This function saves the entire system data, including the PIN ID number, Pattern Scheduler, Conditioner Selection and Maintenance Logs. Do not import backup data from another center unless you know their PIN ID numbers and intend to change your entire system data file.

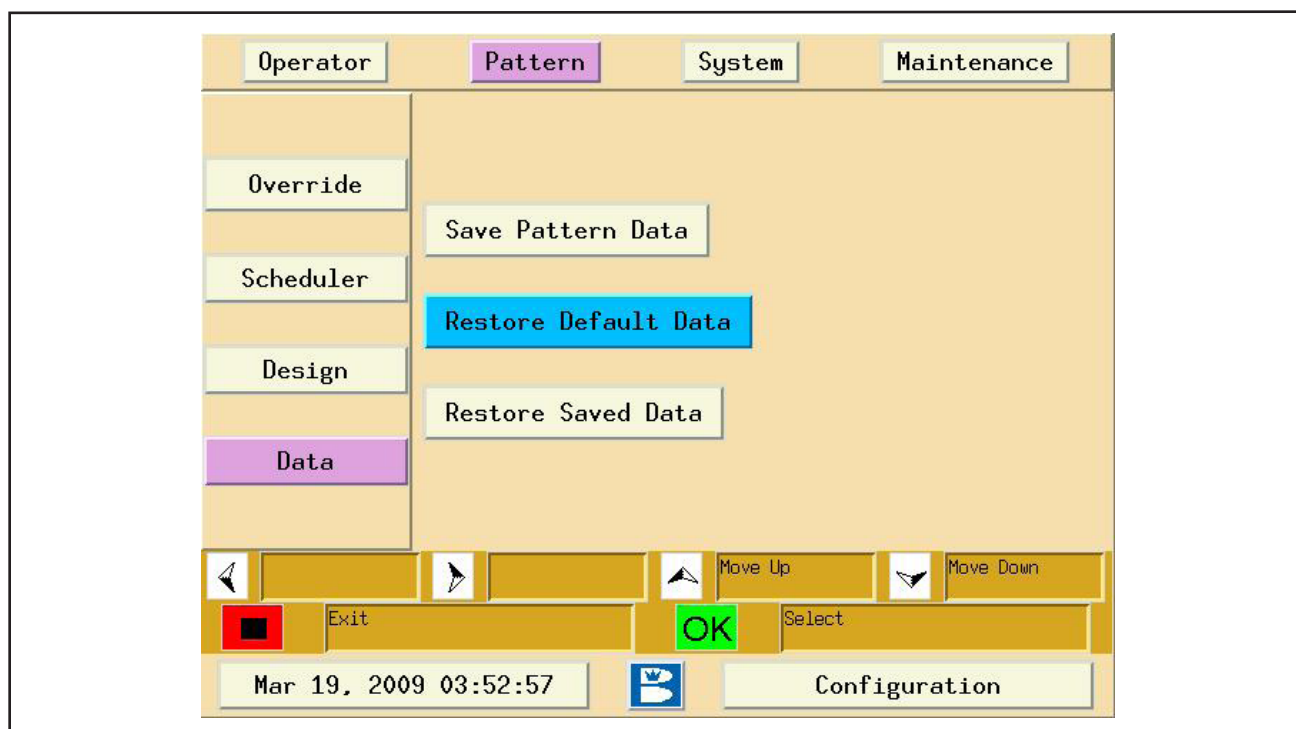

Figure 4-15. Restore Default Data Screen



NOTE:

The default Pattern Data cannot be changed. This function will always restore the 10 starting patterns that were set in the factory. Refer to Figure 4-15

Backing Up and Importing Data

The GUI is designed with a USB port that allows you to connect a USB flash drive for importing or exporting data.

Backing Up Your System

It's important to back up the data in your machine regularly to prevent loss of information. You can backup most data on the Authority22 to an external drive using the USB port on the control box. This capability lets you back up most information on the system in one step. You can save up to five previous system backups. You can backup this data on a PC computer by using the USB flash drive to transfer the data into the PC USB port.

To backup your system:

1. Plug a USB flash drive into the GUI's USB port. The Import/Export screen appears.
2. Use the left/right arrows to select "export" and press "OK."
3. Use the up/down arrows to select the backup folder you want to save to and press "OK" to start the backup.



NOTE:

Only the 10 patterns in the active GUI memory are saved when you backup or export data to the USB flash drive.



CAUTION!

Never remove the USB flash drive from the USB port if the light on the drive is still flashing. Doing so could damage the file system on the USB flash drive. When the text on the GUI returns, it is safe to remove the USB flash drive.

Importing Data

You can also import data via the USB port (except for machine-specific data like name of center, date of installation, etc.). This may be helpful if you've had a system problem and want to restore your settings from a previously saved backup.



NOTE:

This operation will replace the 10 current patterns in active GUI memory, schedules and PINs with older data saved on the USB flash drive. You may want to backup the 10 patterns in active memory as explained above before you import new data. This function saves the entire system data, including the PIN ID number, Pattern Scheduler, Conditioner Selection and Maintenance Logs. Do not import backup data from another center unless you know their PIN ID numbers and intend to change your entire system data file.

To import data:

1. Plug in the USB flash drive into the GUI's USB port. The Import/Export screen appears.

2. Use the right/left arrows to select “import” and press “OK.”
3. Use the up/down arrows to select the backup folder you want to import and press “OK” to import the files. If there are no backups available, the backup folders will appear grayed out.



CAUTION!

Never remove the USB flash drive from the USB port if the light on the drive is still flashing. Doing so could damage the file system on the USB flash drive. When the text on the GUI returns, it is safe to remove the USB flash drive.

The System Screen



NOTE:

This screen may be PIN protected.

About the System Screen

The system menu provides basic information about the bowling center and the machine, and provides a security function to control access to different machine functions. Refer to Figure 4-16.

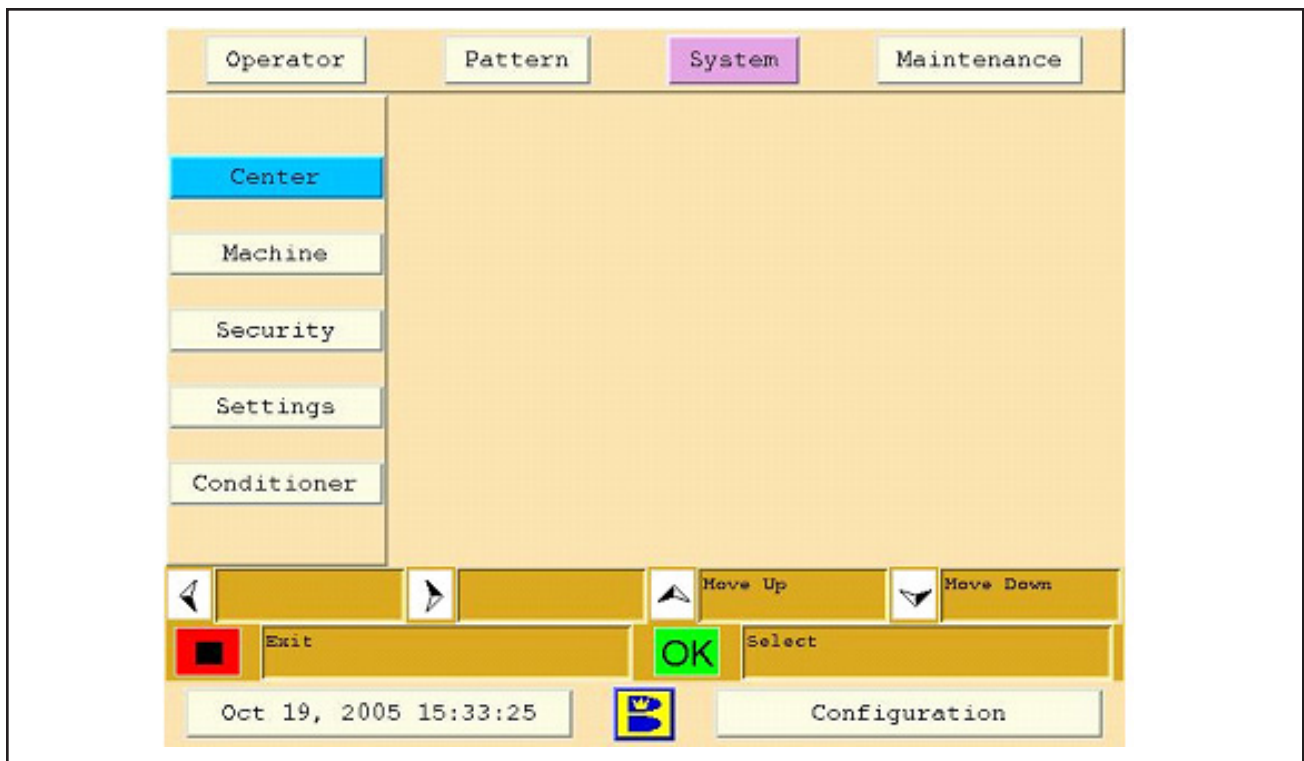

Figure 4-16. System Screen

Center displays the name of the bowling center and the total number of lanes.

Machine displays the date of manufacture and installation, the serial number, and the specifications for the controller and interface.

Security lets you control who has access to the machine's operation and programming.

Settings lets you change the date, time, language, and start distance from the foul line.

Conditioner lets you select the brand of conditioner used in the machine.

System Center

The "Center" screen allows you to enter the name and number of bowling lanes in the center. It is very important to have the correct number of lanes if you are using the scheduler option. Refer to Figure 4-17.



NOTE:

A Certified Brunswick installer will set up this screen with the name of your center and the number of lanes.

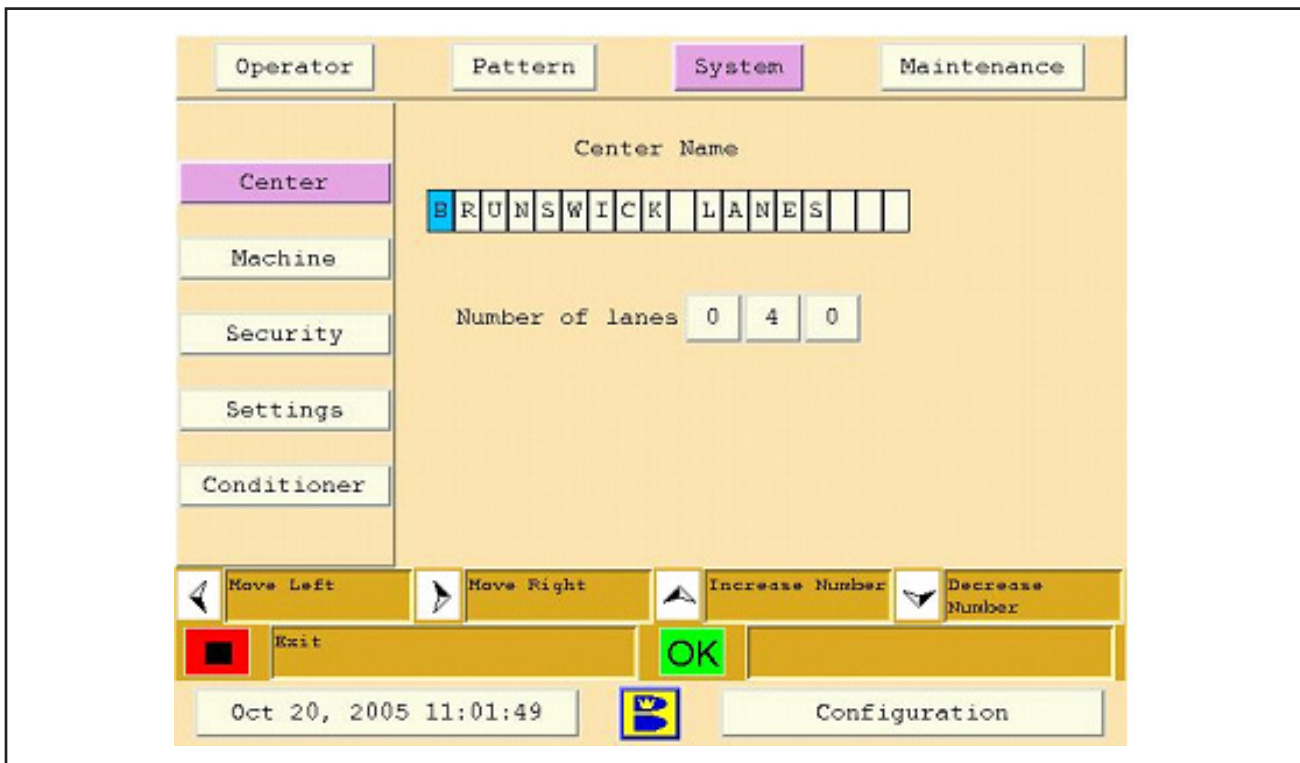

Figure 4-17. System Center

Entering the Name of Your Bowling Center

1. Go to the System menu.
2. Select “Center” & press “OK”.
3. Use the left/right arrows to navigate through the center name.
4. Use the up/down arrows to select a letter, number, or space.

Entering the Number of Lanes

1. Use the left/right arrows to navigate to “Number of lanes”.
2. Use the up/down arrows to enter the number of lanes in your center.



IMPORTANT!:

If you change the number of lanes after initial setup, you may have to update your pattern scheduler (the pattern scheduler uses the number of lanes entered here in establishing schedules).

3. Press “exit” to save and return to the previous screen.

System Machine

The machine screen displays machine information, such as the GUI software and machine control firmware versions, the serial number and ID number of the GUI, date of manufacturing and the date of installation (set by your installer). This information will be required by our Customer Response Center to track the history of the lane machine. Refer to Figure 4-18.

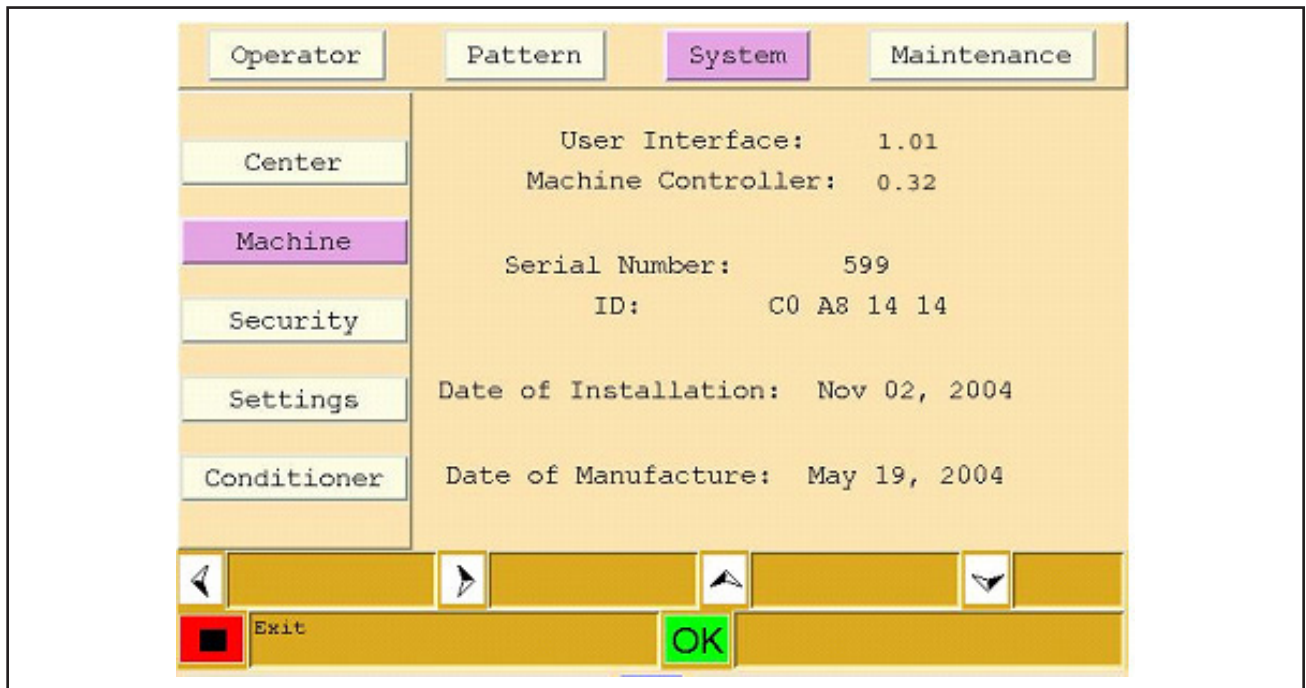

Figure 4-18. System Machine

Accessing Basic Identifying Information About Your Machine

1. Go to the System menu.
2. Select “Machine” & press “OK”.
3. This screen displays the serial number of your GUI, the software version of the **User Interface** and **Machine Controller**, the date of manufacture, the date of installation, and other general information.

System Security

The system security on the Authority22 enables you to safely protect your critical machine settings from unwanted access. When completely enabled, the machine will track every action taken by a user during the time they are logged in.

Setting Up PINs

Information in the Pattern, System, and Maintenance menus can be protected from unauthorized access by setting up to 10, 4 digit PINs (personal identification numbers) for different users. The ten ID numbers (1-10) will display a status for each position.

ID number zero (0) is used to enable a “Log-in” feature that requires a four digit access code prior to being able to access the operators screen. A user with a valid PIN number is allowed to log-in and accountability during that session will be assigned to that user. The pattern change log and the pattern run log will assign the users name for each action taken during operation. Users not assigned PIN numbers will be restricted from viewing or operating the GUI and lane machine.

If you do not assign PINs, all users will have access to all operations and menus.

If you assign PINs, each user can also be assigned a security level that determines which machine functions and menus he or she can access. You can choose between 2 security levels:

Level 1 is generally for machine operators. It allows the user to run lanes, and it allows access to the pattern override function and most maintenance menus. Menus that may affect the performance of a conditioning pattern will be restricted in this security level.

Level 2 is generally for managers or mechanics. It allows the user access to all screens, menus, and operations.

If, for any reason you lose your PIN and need access to the machine, please contact your authorized Distributor or the Brunswick Customer Response Center (CRC) in the United States at 1-800-YES-BOWL, or internationally at 231-725-4966. For non emergency support, e-mail crcsupport@brunbowl.com. We will assign you a temporary PIN and help you with the reset process.

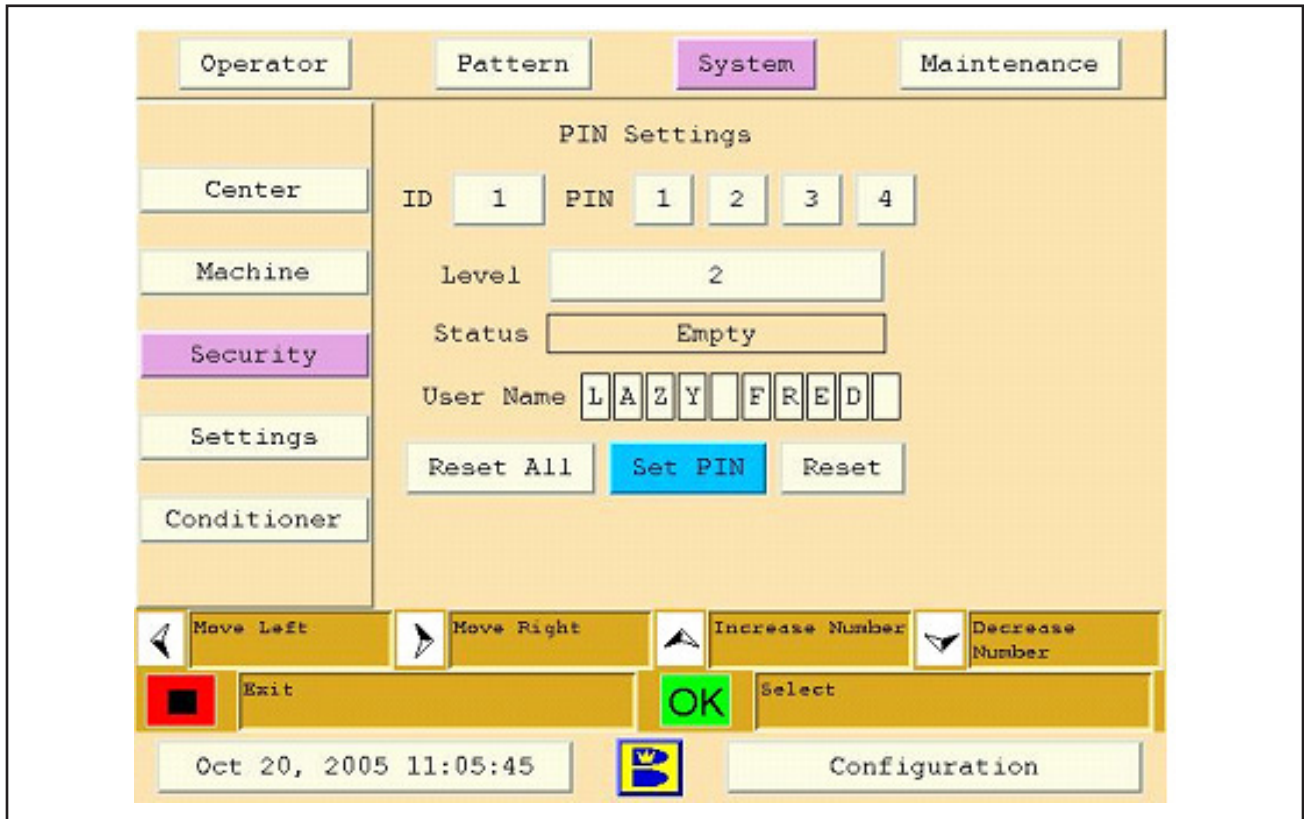

Figure 4-20. System Security

To Set a PIN

1. Go to the System menu. Refer to Figure 4-20.
2. Select “Security” & press “OK”.
3. Use the up/down arrows to select an ID number (0 is always the login PIN).
 - a. To enter a new PIN, select an “empty” ID number.
4. Use the left/right and up/down arrows to create a 4 digit PIN.
5. Select a security level.
 - a. 1 = Operator – Pin number provides access to pattern override and some maintenance menus only.
 - b. 2 = Manager/Mechanic level – pin number provides access to all functions and systems.
6. Enter a user name for this pin number.
7. Use the left/right arrow to navigate to “Set PIN”.



NOTE:

If the PIN is already assigned to a different user (ID) a warning message will indicate that you must enter a different number.



NOTE:

Once PIN is set, the status line will display “assigned” (instead of “empty”) and the 4 digit PIN will display as all zeroes for security reasons.

8. Press “exit” to save and return to the previous screen.

Changing PINs

1. Go to the System menu.
2. Select “Security” & press “OK”.
3. Use the right/left arrows to navigate to PIN.
4. Use the up/down arrows to change the PIN number.
5. Press “exit” to save and return to the previous screen.



NOTE:

Updating the user ID requires you to also change the PIN number.

Resetting PIN Access



NOTE:

You can reset the PIN security if you want all users to have access to all information

1. Go to the System menu.
2. Select “Security” & press “OK”.
3. Navigate to “Reset All” and press “OK”.
4. Press “exit” to save and return to the previous screen.

System Settings

The system settings are used to set clock functions like the date and time, date format (MM/DD/YY or DD/MM/YY). The Temperature Cycle allows the user to enable or disable the oil heating function (we recommend this feature to be “on”) during which the conditioning system cycles conditioner and steadily heats it to 80° Fahrenheit (~26° Centigrade). Operators may choose the language they prefer. The default start distance from the foul line must be selected, so no pattern may be set to apply conditioner between this setting and the foul line. The operator can change their Units of measure from Imperial (US) to Metric (International), and the number of lanes they wish to be able to run after the first low fluid level message appears. Refer to Figure 4-21.

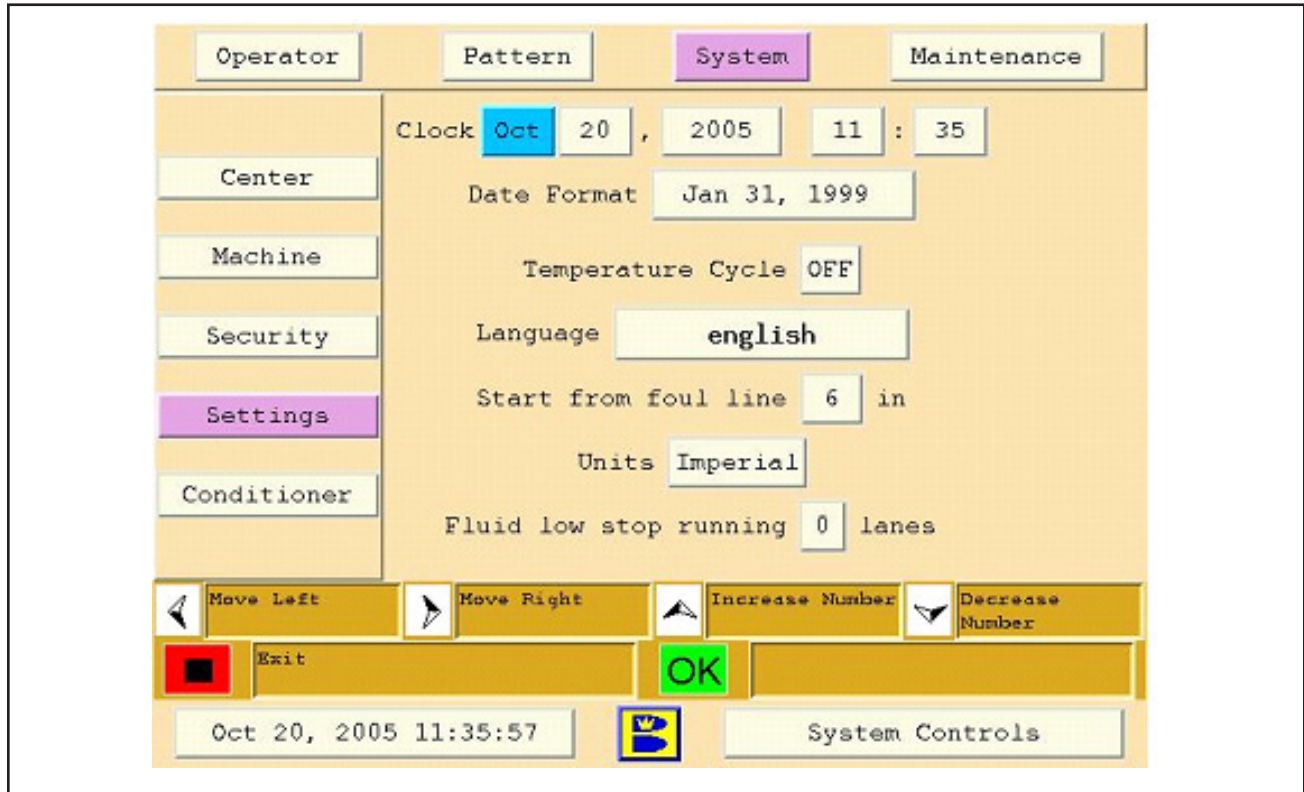

Figure 4-21. System Settings

Changing the Date and Time

1. Go to the System menu.
2. Select “Settings” & press “OK”.
3. Use left/right arrows to navigate to “Clock”.
4. Use up/down arrows to change month/date/time.
5. Press “exit” to save and return to the previous screen.

Changing the Date Format

1. Go to the System menu.
2. Select “Settings” & press “OK”.
3. Use left/right arrows to navigate to “Date Format”.
4. Use up/down arrows to select the format you prefer.
5. Press “exit” to save and return to the previous screen.

Changing the Temperature Cycle



NOTE:

The temperature cycle allows the machine to heat the conditioner to a constant temperature throughout the conditioning process. This offers the greatest consistency of the conditioning pattern from one lane to another. Since the viscosity of a conditioner can change with varying temperatures, we recommend that this function be used (especially in areas around the world that the temperature changes significantly through the course of a year or if the lane machine and conditioner is stored in a cold location). Target temperature is 80° Fahrenheit. (-26° Celsius). Operating within 10° Fahrenheit (-12.2° Celsius) +/- the target temperature will have minimal effect on the pattern.



WARNING!

Do not stand machine upright (transport position) with power cord attached or power supplied.

1. Go to the System menu.
2. Select “Settings” and press “OK”.
3. Use the left/right arrows to navigate to “Temperature Cycle”.
4. Use the up/down arrows to select between “On” and “Off”.
5. Press “exit” to save and return to the previous screen.

Changing the Language

1. Go to the System menu.
2. Select “Settings” and press “OK”.
3. Use the left/right arrows to navigate to “Language”.
4. Use the up/down arrows to select from the list of languages.
5. Press “exit” to change the language and return to the previous screen.

Changing the Conditioner Start Distance from the Foul Line



IMPORTANT:

For bowler safety, you should not start dispensing oil at the foul line. You can set the start distance from the foul line in increments of 6' (152mm) between 6 and 24 inches (15.24 to 60.96 cm). 6" (152mm) is the minimum value and no pattern may start closer to the foul line than the value selected in this box.

1. Go to the System menu.
2. Select “Settings” and press “OK”.
3. Use the left/right arrows to navigate to “Start from foul line”.
4. Use the up/down arrows to change the start distance.
5. Press “exit” to save and return to the previous screen.

Changing the Units of Measure (Imperial vs. Metric)



NOTE:

You can change from Imperial to Metric units of measure. If you do so, all units of distance and temperature that appear on the GUI will be converted to the new standard.

1. Go to the System menu.
2. Select “Settings” and press “OK”.
3. Use the left/right arrows to navigate to “Units”.
4. Use the up/down arrows to switch between Imperial and Metric units.
5. Press “exit” to save and return to the previous screen.

Changing the Fluid Low Stop Running Function



NOTE:

The GUI alerts you when you are running low on conditioner or cleaner fluid and will shut down the machine in low-fluid situations to prevent damage to the machine. You may select the number of lanes you can run—between 0 and 3—after a low-fluid warning. After 3 lanes, the machine will automatically shut down until you have refilled the fluids.

1. Go to the System menu.
2. Select “Settings” and press “OK”.
3. Use the left/right arrows to navigate to “fluid low stop running”.
4. Use the up/down arrows to select the number of lanes you can run after the fluid low warning message displays.
5. Press “exit” to save and return to the previous screen.

Conditioner

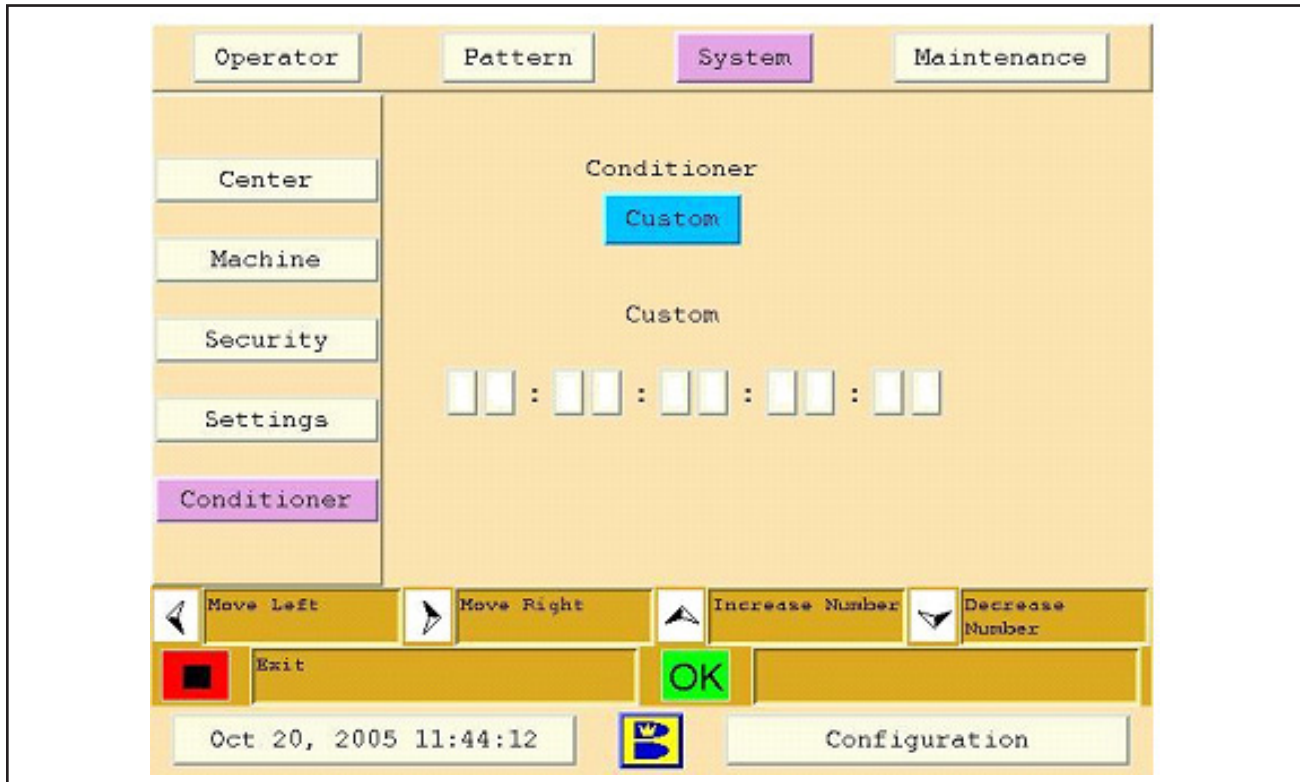

Figure 4-22. Conditioner

Changing Conditioner



NOTE:

If you change conditioners, you must identify the brand of conditioner you are using to ensure proper operation. Different conditioners have different flow rates, which may require the machine to recalculate conditioner patterns. If your brand is not listed, select “Custom” and please contact your authorized Distributor or the Brunswick Customer Response Center (CRC) in the United States at 1-800-YES-BOWL, or internationally at 231-725-4966. For non emergency support, e-mail crcsupport@brunbowl.com, to get the flow values for that brand.

1. Go to the System menu. Refer to Figure 4-22.
2. Select “Conditioner” and press “OK”.
3. Use the up/down arrows to select the conditioner brand.
4. Press “exit” to save and return to the previous screen.



NOTE:

Selecting a different conditioner will require the download of all patterns.

The Maintenance Screen



NOTE:
This screen may be PIN protected.

About the Maintenance Screen

The maintenance screen provides information about the long-term use and maintenance of the machine. Refer to Figure 4-23.

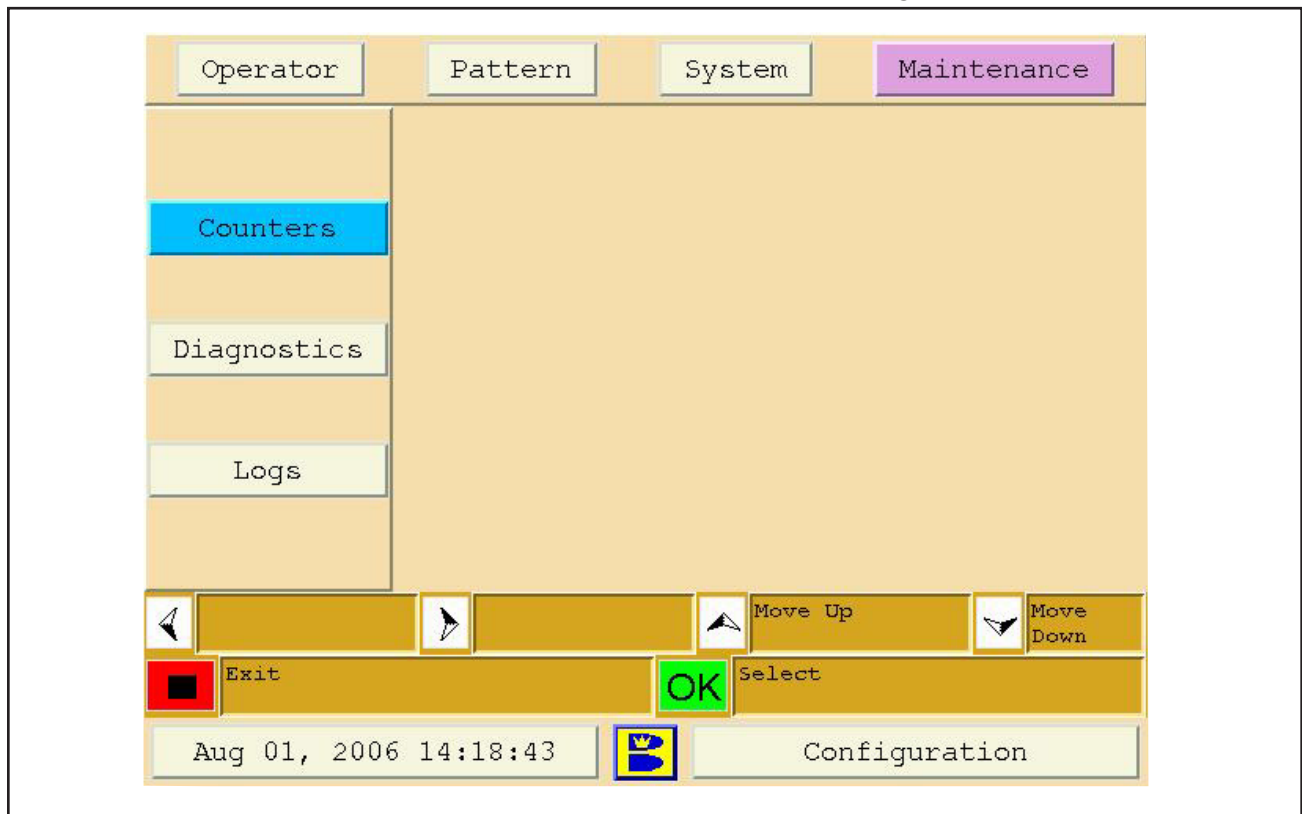

Figure 4-23. Maintenance

Counters display the total lanes run, the amount of use on a variety of replaceable parts, and alerts you when a part is reaching the end of its useful life. These will generate a warning message when the counter expires. The maintenance message will continue to appear before running each lane until the counter is reset.

Diagnostics shows the current state of all major hardware devices and allows you to cycle motors on and test sensors and switches for troubleshooting purposes.

Logs keeps and displays records of pattern changes, patterns run, maintenance, and error messages.

Maintenance Counters

The Authority22 monitors the life of consumable items that will need periodic replacing or cleaning. Life expectancy of most items are based on the number of lanes they will perform. Motors are monitored in the number of hours they are used. After you replace a part, you must reset the counter for that part to start the counter for the new part (the duster cloth counter will reset automatically if the duster cloth is changed during a running session via the “change duster cloth” button in the Operator’s Screen). A list of the counter values is shown in section 6.

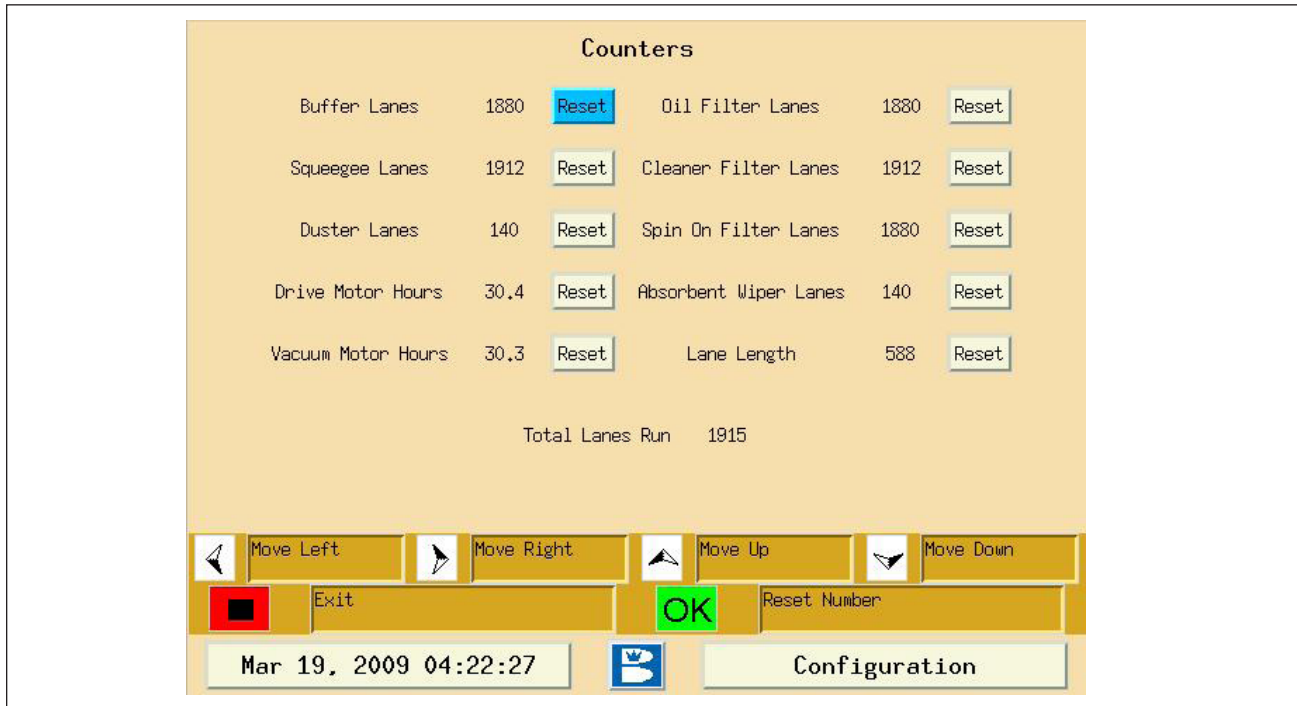

Figure 4-24. Maintenance Counters

Viewing and Resetting Counters

1. Go to the Maintenance menu. Refer to Figure 4-24.
2. Select “Counters” and press “OK”.
3. Use the up/down arrows to navigate to the counter to be reset and press “OK”.
4. The counter will reset the number of lanes to “0” on the item you select.
5. Press “exit” to save changes and return to the previous screen.



NOTE:

Changes will not be saved until screen is exited. Be sure that you select the correct counter before pressing reset.



NOTE:

You can't reset the counter for Total Lanes Run.

Maintenance Diagnostics

This menu allows you to operate the pumps and motors and test the operation of sensors and switches. Diagnostics is an invaluable function for troubleshooting machine problems. *Refer to Section 6.0 Troubleshooting for more information.* Refer to Figure 4-25.

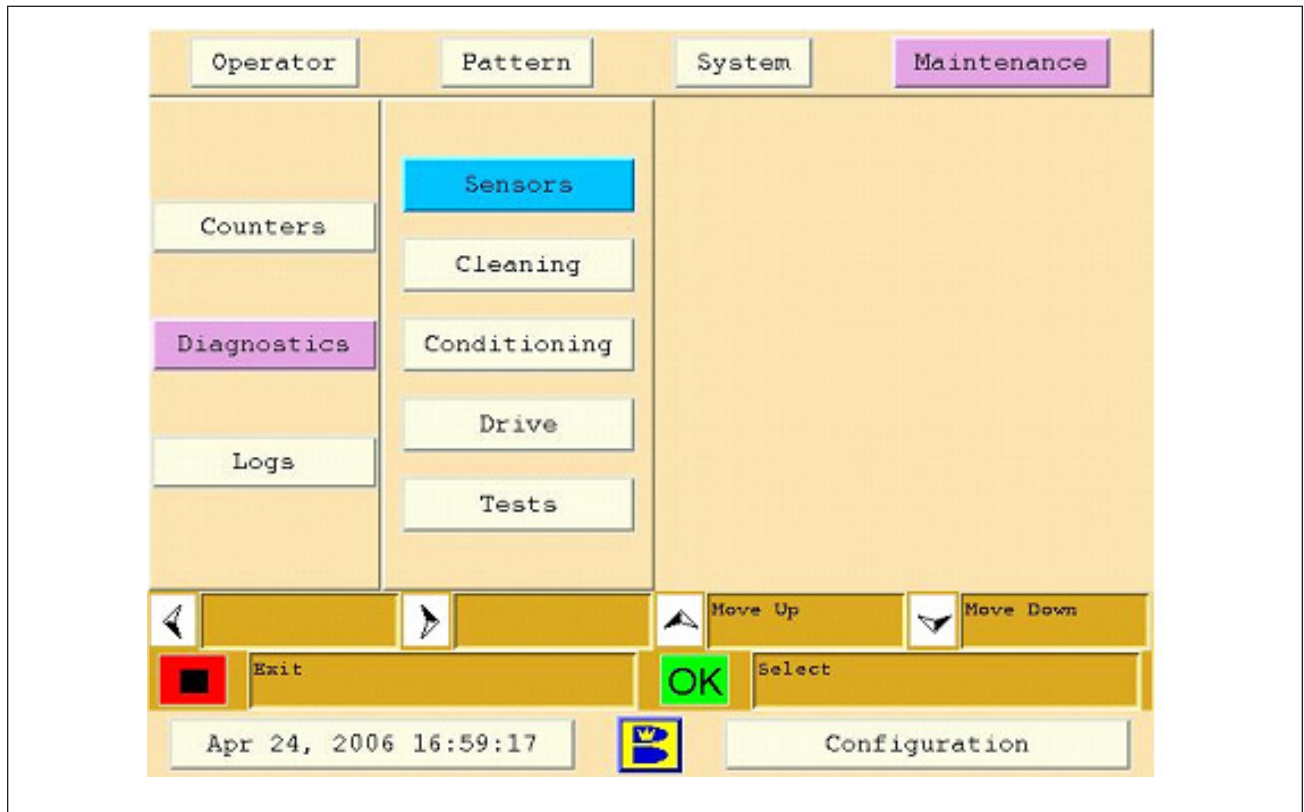

Figure 4-25. Maintenance Diagnostics

Sensors

This menu lets you view the current status of all sensors or switches for diagnostic purposes. Refer to Figure 4-26.

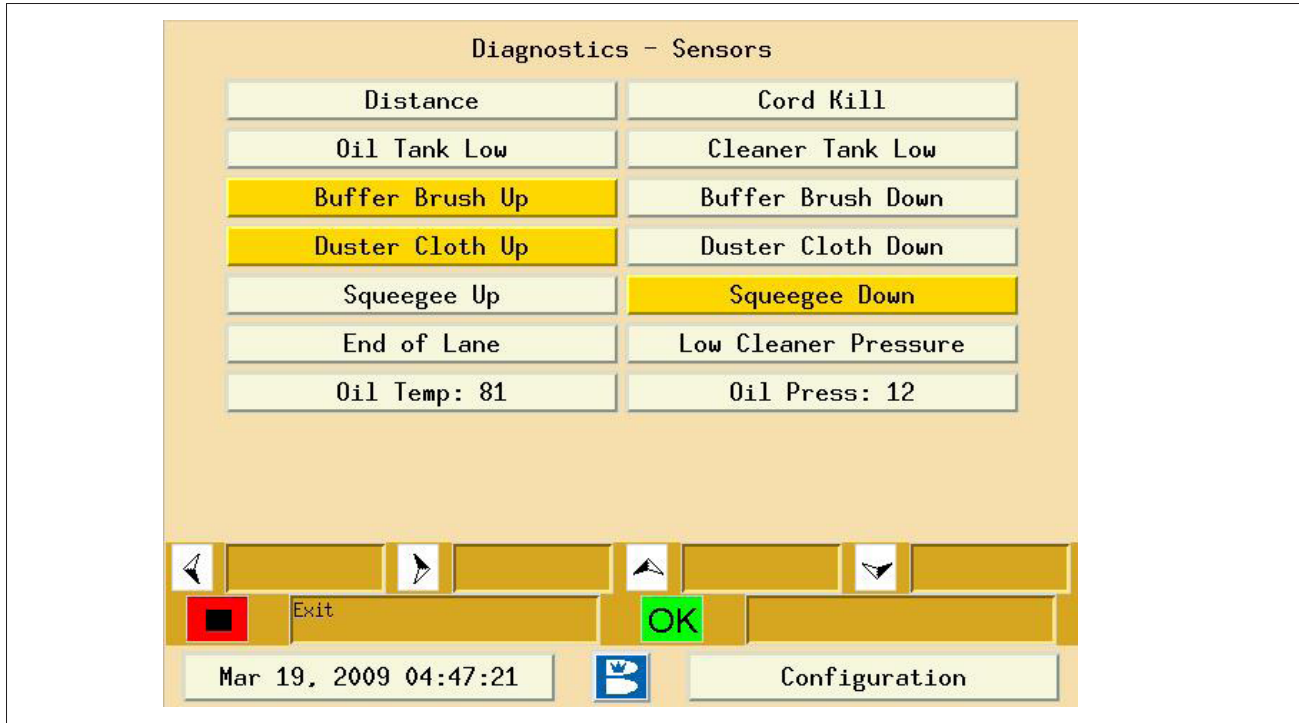

Figure 4-26. Diagnostics Sensors

1. Go to the Maintenance menu.
2. Select "Diagnostics" and press "OK".
3. Use the up/down arrows to navigate to "Sensors" and press "OK" to see the machine sensors.
4. If a sensor is active or "on," it will be highlighted in color.

Cleaning

This menu lets you view the current status of all sensors or switches, and view or test all motors in the cleaning system. Refer to Figure 4-27.

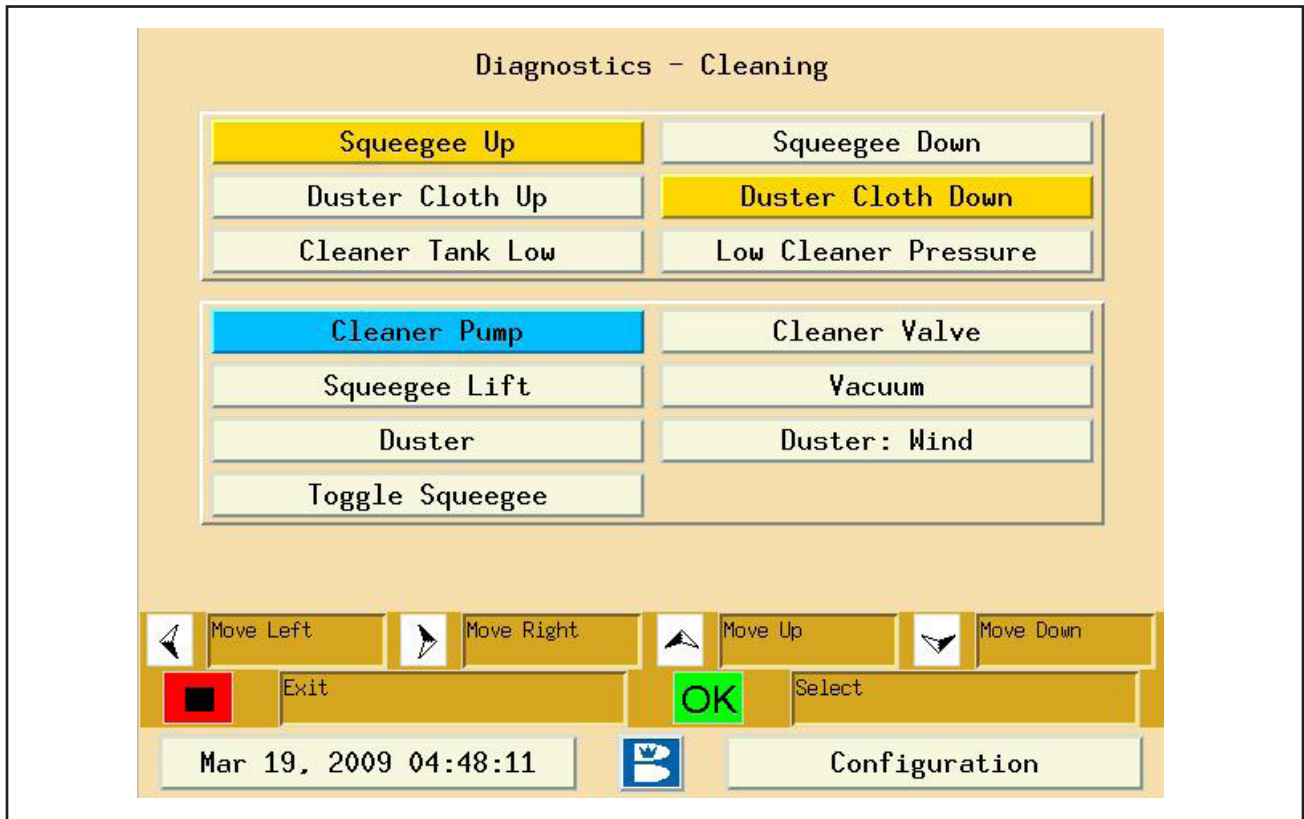

Figure 4-27. Diagnostics Cleaning

To view a cleaning system sensor position or test a motor function:

1. Go to the Maintenance menu.
2. Select "Diagnostics" and press "OK".
3. Use the up/down arrows to navigate to "Cleaning" and press "OK".
4. To check sensors, review the list of sensors on the upper half of the screen. If a sensor is active or "on," it will be highlighted in color.
5. To test the motors, valves, and pumps of the cleaning system, review the list on the lower half of the screen. You can turn each device off or on for a limited period of time for diagnostics or maintenance purposes.

Conditioning

This menu lets you view the current status of all sensors or switches, and view or test all motors in the conditioning system. Refer to Figure 4-28.

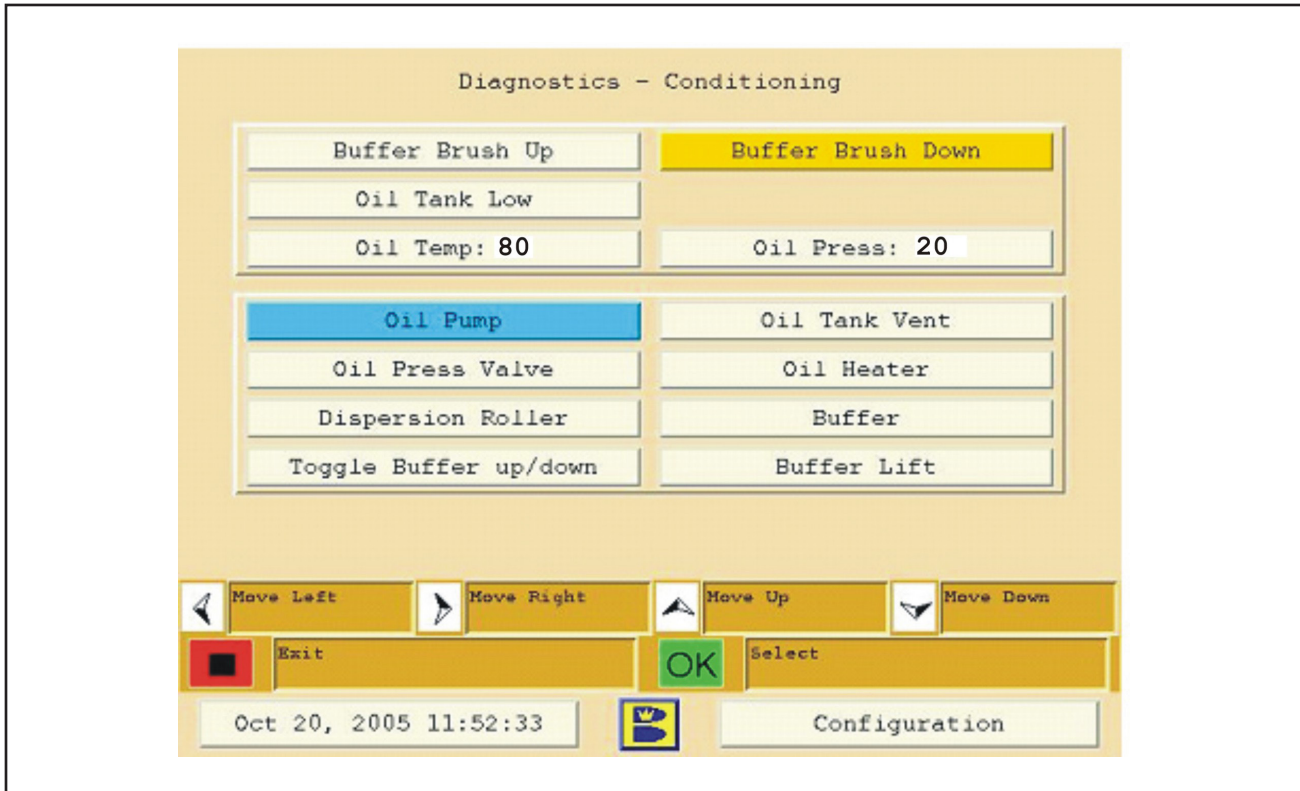

Figure 4-28. Diagnostics Conditioning

To view a conditioning system sensor position or test a motor function:

1. Go to the Maintenance menu.
2. Select “Diagnostics” and press “OK”.
3. Use the up/down arrows to navigate to “Conditioning” and press “OK”.
4. To check sensors, review the list of sensors on the upper half of the screen. If a sensor is active or “on,” it will be highlighted in color.
5. To test the motors, valves, and pumps of the conditioning system, review the list on the lower half of the screen. You can turn each device off or on for a limited period of time for diagnostics or maintenance purposes.

Drive

This menu lets you view the readings of the distance encoder (labeled “Distance”) and test the drive mechanism in forward and reverse. Refer to Figure 4-29.

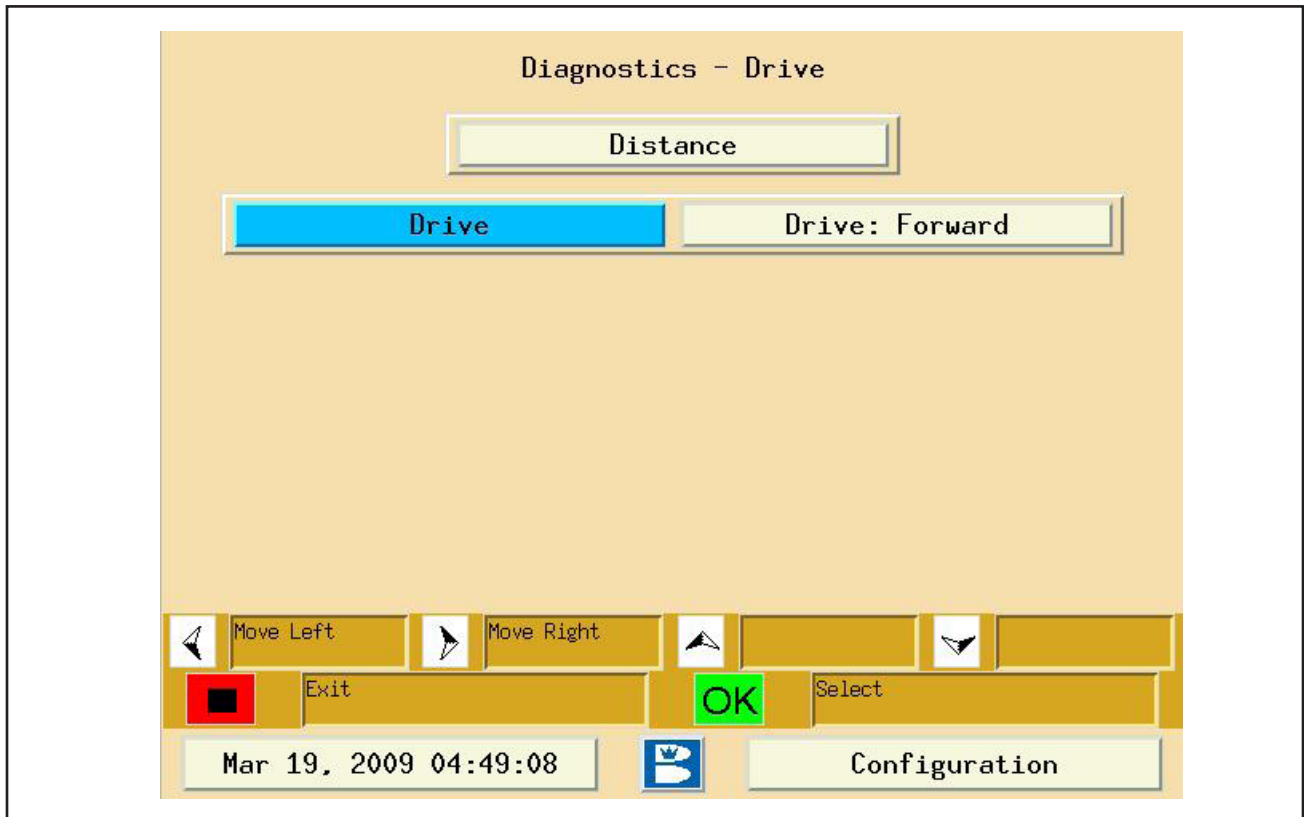

Figure 4-29. Diagnostics Drive

To view the drive system sensor position or test a motor function:

1. Go to the Maintenance menu.
2. Select “Diagnostics” and press “OK”.
3. Use the up/down arrows to navigate to “Drive” and press “OK” .
4. To test the distance encoder, manually spin the rear shaft. The screen will display the activation of the encoder sensor in the “Distance” box.
5. To test the drive mechanisms, select between “Drive: Forward” or “Drive: Reverse” and then select “Drive” to test the forward or reverse drive systems.

Tests

The Tests diagnostics function allows the user to perform specific tests on the injectors to verify that all injectors are firing properly and to test the cleaner spray coverage, on the lane, at maximum (25-30 psi) and minimum (20-25 psi) pressures. Refer to Figure 4-30.

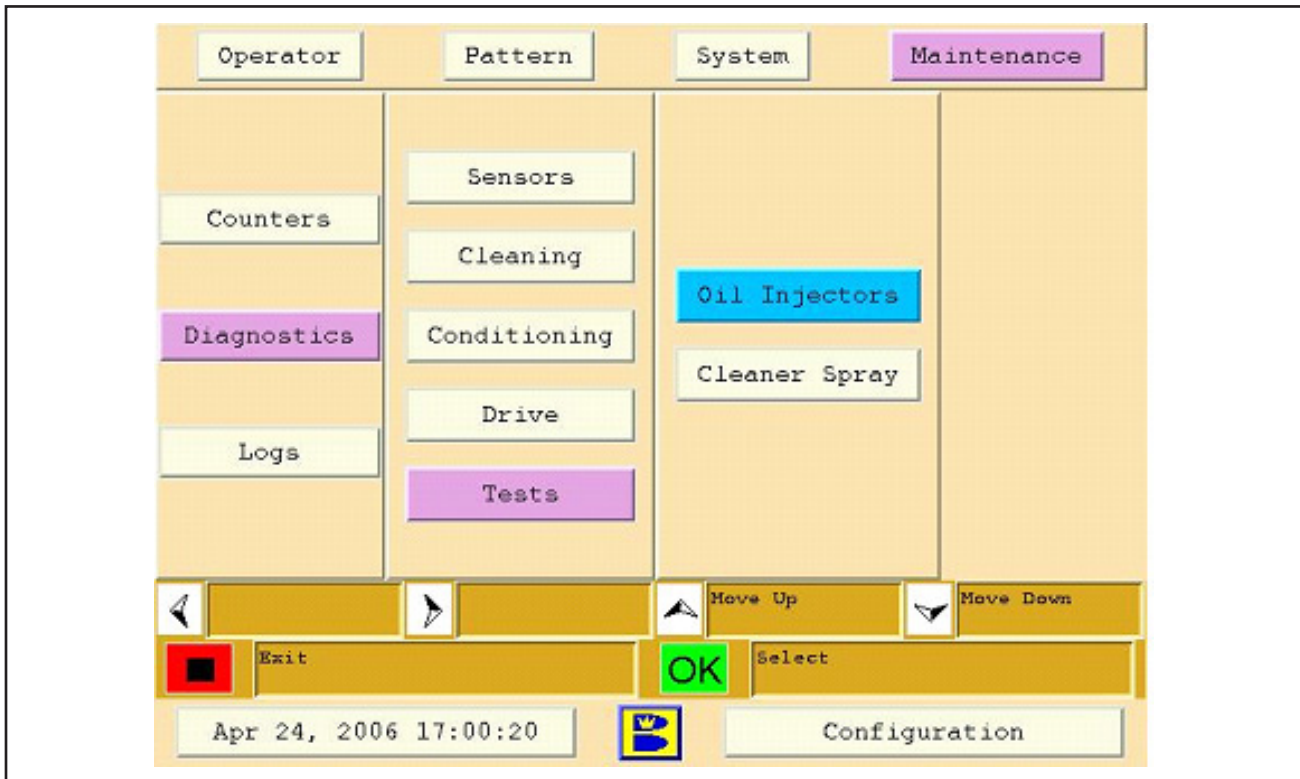

Figure 4-30. Diagnostics Tests

Oil Injector Test

The test for the Oil Injectors is designed for the technician to visually see each injectors spray pattern. This diagnostic function verifies that each injector is firing properly and to identify if an injector has failed or not creating the appropriate spray pattern. The machine will travel approximately 25 feet down the lane during this test. The process includes cleaning the lane and firing each injector in a sequential order allowing the technician to easily see each injection without interference by the buffer brush.

To test the Oil Injectors on the lane:

1. Go to the Maintenance menu.
2. Select "Diagnostics" and press "OK".
3. Use the up/down arrows to navigate to "Tests" and press "OK".

4. Select the Oil Injector test, press “OK” and the following screen will appear (“Oil Injector” will appear at the top of the screen for the injector test). Refer to Figure 4-31.

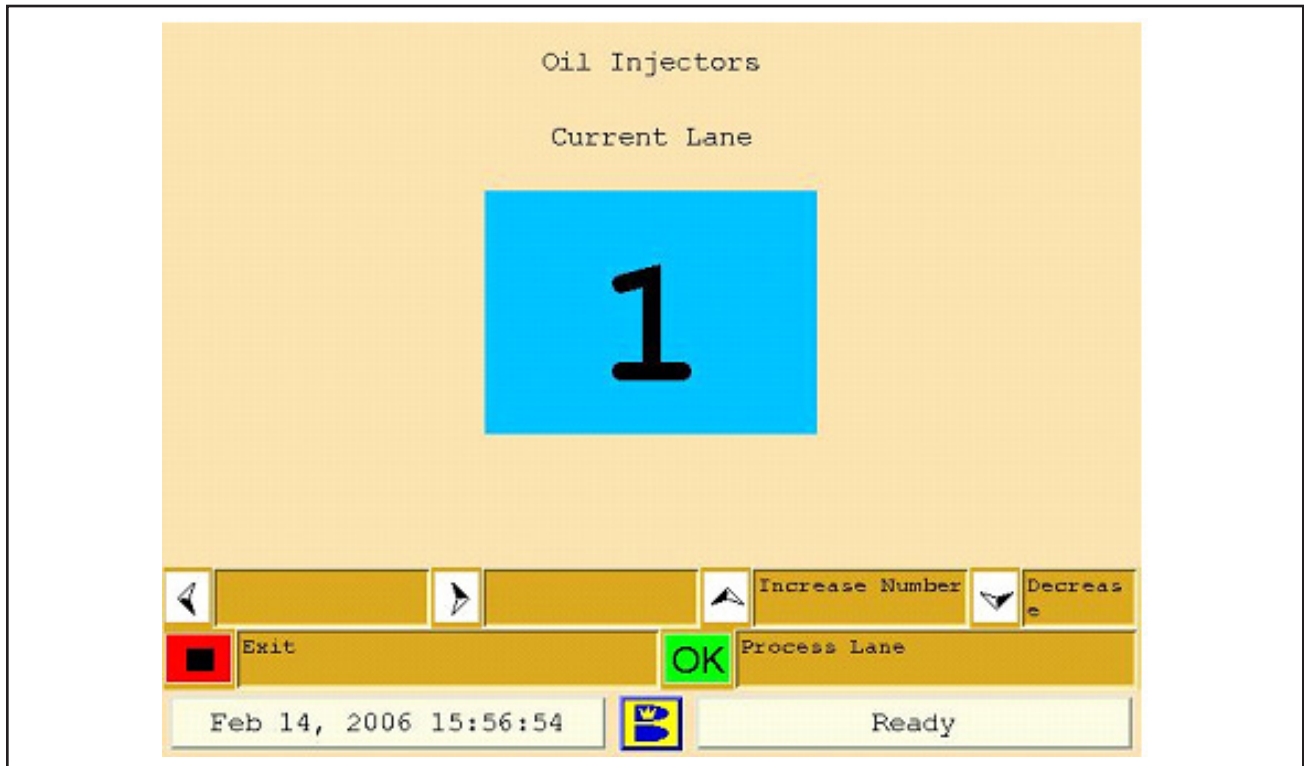

Figure 4-31. Oil Injectors

5. Press “OK” to prepare the machine for operation. This may require a pattern download.
6. Put the lane machine on the lane when the message appears.
7. Press “OK” to start the test.



NOTE:

The machine will automatically clean approximately the first 25 feet of the bowling lane and inject at the same time while performing this test. Perform a clean only or a clean and condition after completion of the Oil Injector test.

Cleaner Spray Test

The test for the Cleaner spray is used to verify the coverage for both the maximum and minimum spray pressures. This test allows the technician to visually see how well the cleaning spray is covering the lane during a cleaning run. The process is performed in two passes of the lane machine. The first pass of the machine will clean approximately 25 feet of the bowling lane. The second pass sprays cleaner to the bowling lane as it travels without interference of the duster and the squeegee assembly. The cleaner will transition from maximum to minimum about half way through the second run.

To test the Cleaner Spray on the lane:

1. Go to the Maintenance menu.
2. Select “Diagnostics” and press “OK”.
3. Use the up/down arrows to navigate to “Tests” and press “OK”.
4. Select the Cleaner Spray test, press “OK” and the following screen will appear (“Cleaner Spray” will appear at the top of the screen for the spray test). Refer to Figure 4-32.

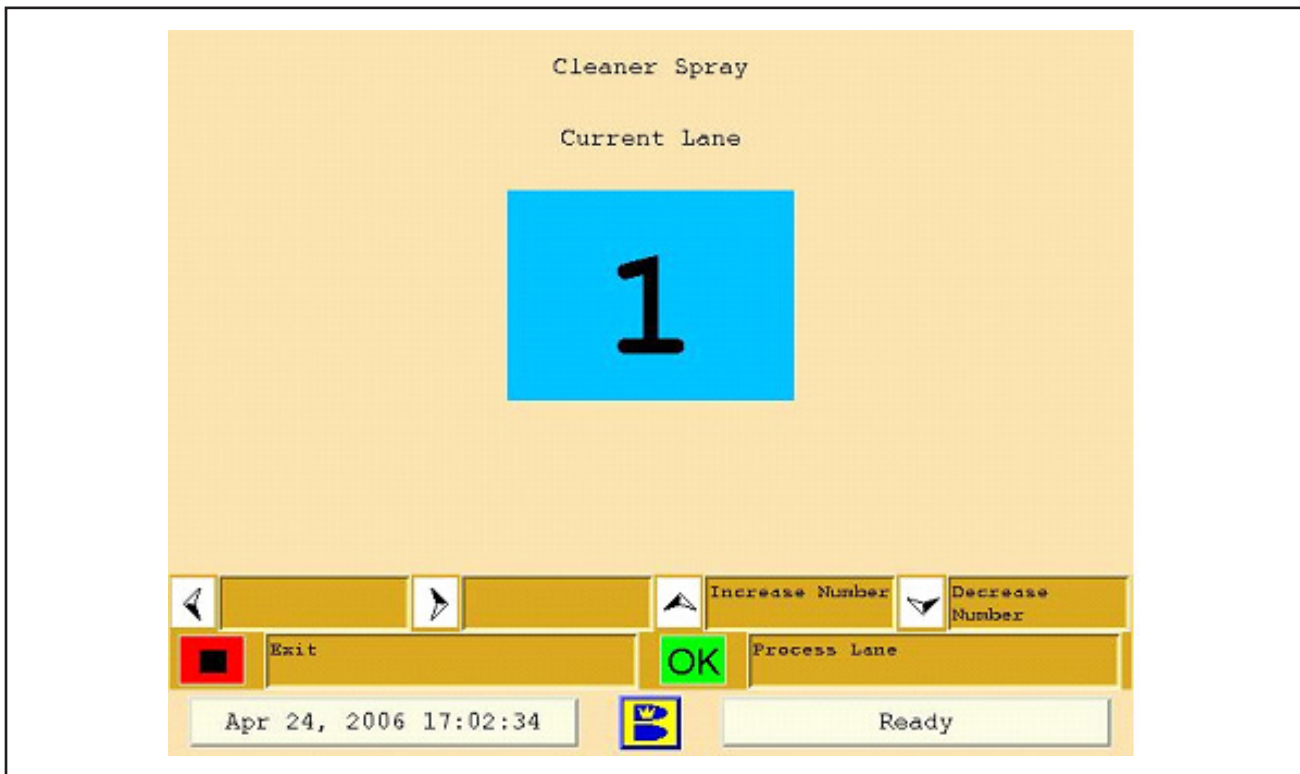

Figure 4-32. Cleaner Spray

5. Press “OK” to prepare the machine for operation.
6. Put the lane machine on the lane when the message appears.
7. Press “OK” to start the test. The machine will clean the first 25 feet of the lane.
8. After the machine returns to the foul line, press “OK” again to complete the Cleaner Spray test utilizing the cleaner spray only.



NOTE:

It is important to either clean only or clean and condition the lane after performing the Cleaner Spray test. Do not allow cleaner to dry on the bowling lane.

Maintenance Logs

Most programming changes and all of the maintenance and error messages displayed are tracked and can be viewed on the Logs screen to make troubleshooting faster and more reliable. Users with Level 1 or 2 security access can view all logs. **Logs cannot be edited or deleted by the user.** Refer to Figure 4-33.

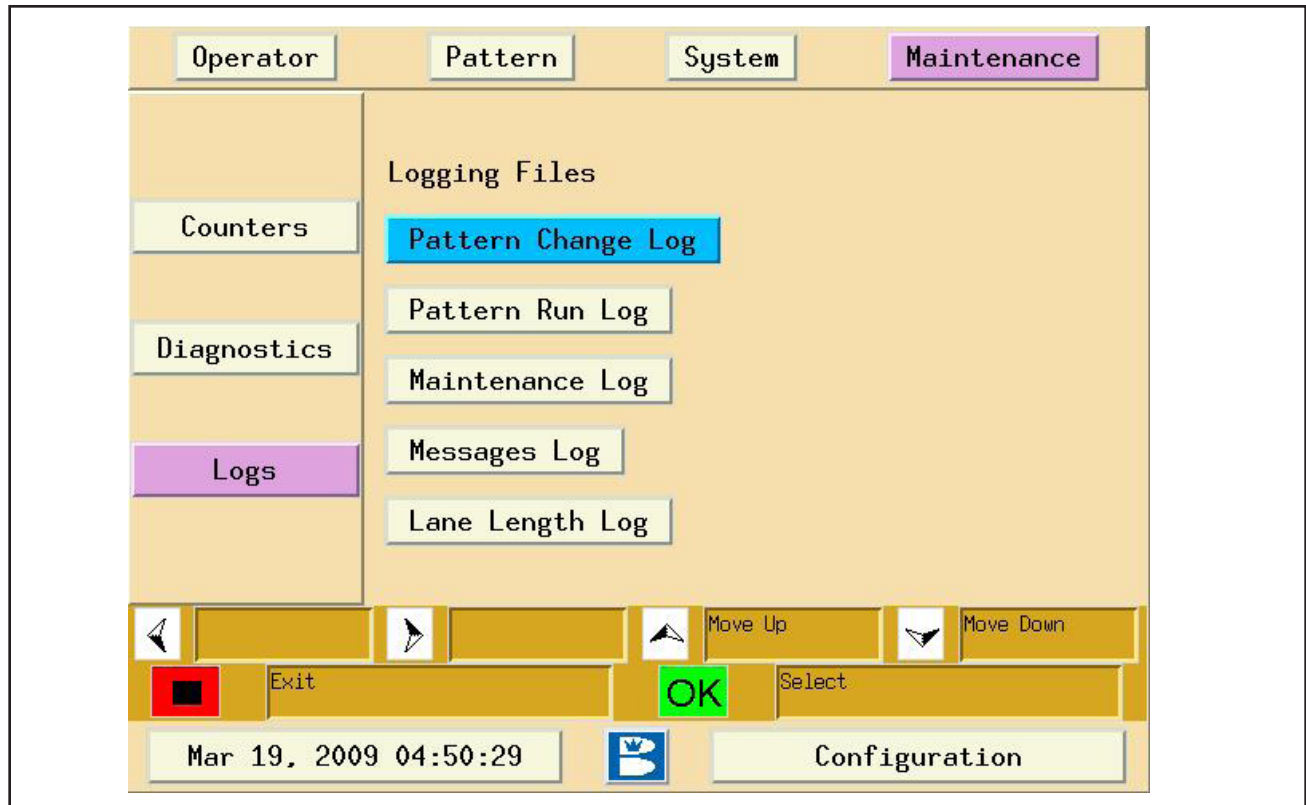

Figure 4-33. Maintenance Logs

Pattern Change Log

This log tracks all changes to any pattern parameter or pattern modifications. It also logs the date and time of the change and the ID of the user who made the change, if the login feature is enabled.

1. Go to the Maintenance menu.
2. Select "Logs" and press "OK".
3. Use the up/down arrows to navigate to select "Pattern Change Log" and press "OK".
4. Use the up/down arrows to view the entire log.

Pattern Run Log

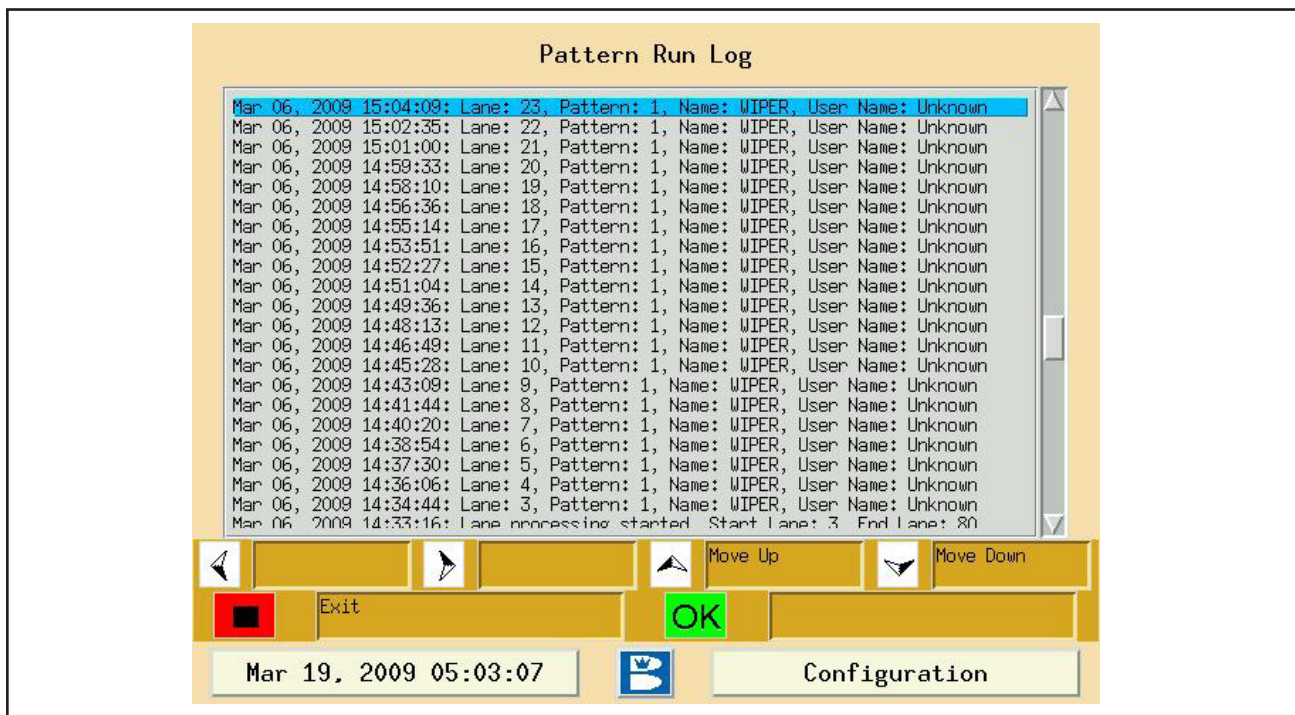

Figure 4-34. Pattern Run Log

This log provides historical information on the machine's operations including what lanes were run, in what order the lanes were run, the times the lanes were run, which patterns were run on each lane, any pattern overrides, and the ID of the user who ran the lanes, if the login feature is enabled. Refer to Figure 34.

1. Go to the Maintenance menu.
2. Select "Logs" and press "OK".
3. Use the up/down arrows to navigate to select "Pattern Run Log" and press "OK".
4. Use the up/down arrows to view the entire log.

Maintenance Log

This log tracks when hardware items needed to be replaced, when counters were reset, and provides a date and time stamp and user name to verify when these actions took place.

1. Go to the Maintenance menu.
2. Select "Logs" and press "OK".
3. Use the up/down arrows to navigate to select "Maintenance Log" and press "OK".
4. Use the up/down arrows to view the entire log.

Messages Log

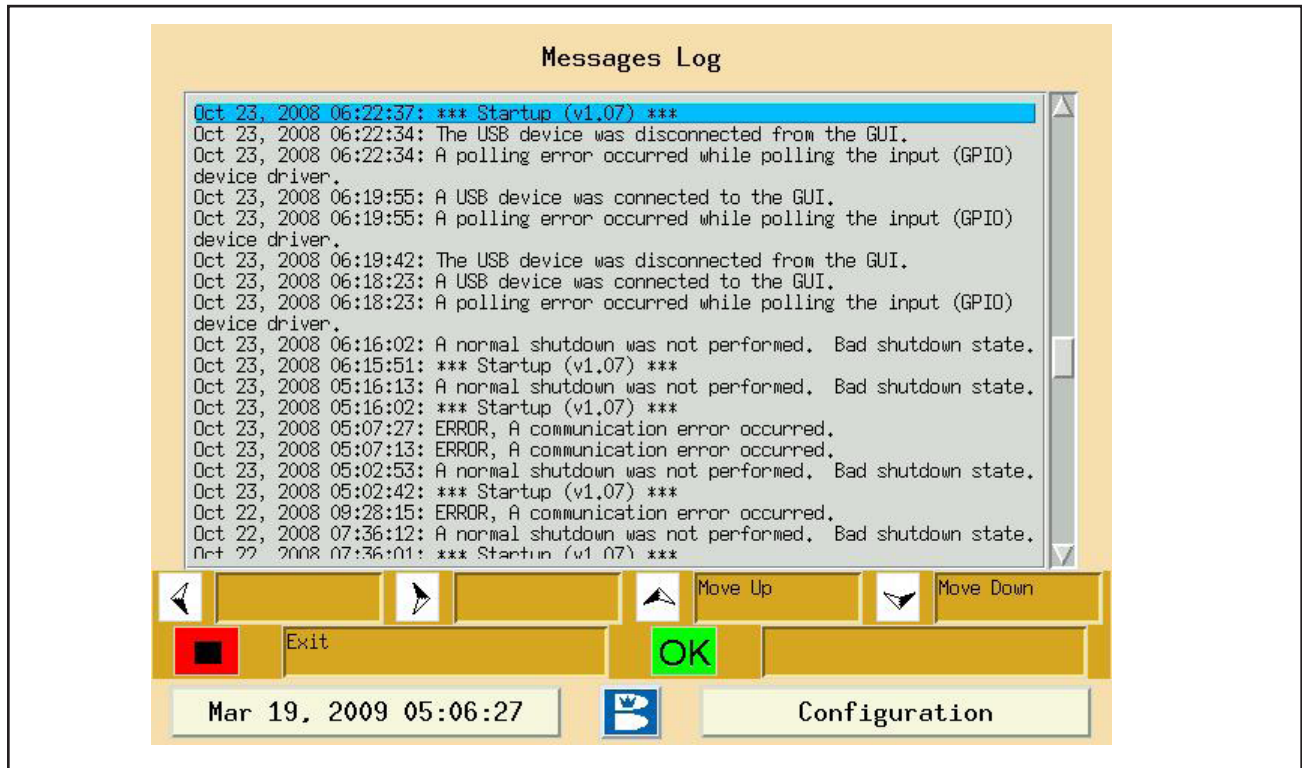

Figure 4-35. Messages Log

This log tracks all errors and warning messages and provides a date and time stamp to verify when those messages were displayed. Refer to Figure 35.

1. Go to the Maintenance menu.
2. Select “Logs” and press “OK”.
3. Use the up/down arrows to navigate to select “Messages Log” and press “OK”.
4. Use the up/down arrows to view the entire log.



NOTE:

Maintenance logs can be backed up to a USB flash drive as explained earlier in Section 4, "Backing Up and Importing Data". These logs may contain information that is helpful to the Brunswick Customer Response Center when troubleshooting issues. They can explain how to attach backup files to an e-mail or ship the USB flash drive with your center maintenance logs. The maintenance logs, counters and critical center data cannot be imported back to your GUI.

Lane Length Log

The screenshot shows a graphical user interface titled "Lane Length Log". It features a table with the following data:

Lane	Avg	Hi	Lo	1st	2nd	3rd
001	588	589	587	588	588	587
002	588	589	587	587	588	588
003	588	589	587	588	589	588
004	588	589	587	588	588	588
005	588	589	587	589	588	588
006	588	589	587	588	587	589
007	588	589	587	588	588	588
008	588	589	587	588	588	588
009	588	589	587	587	588	587
010	588	589	587	588	589	588
011	588	589	587	588	588	588
012	588	589	587	588	588	588
013	588	589	587	589	588	588
014	588	589	587	588	588	589
015	588	589	587	587	587	588
016	588	589	587	588	588	588
017	588	589	587	588	588	588
018	588	589	587	588	588	587
019	588	589	587	589	589	588
020	588	589	587	588	588	588
021	588	589	587	588	588	588

Below the table is a control panel with buttons for "Move Up", "Move Down", "Exit", and "OK". At the bottom, there is a date and time display showing "Mar 19, 2009 05:13:58" and a "Configuration" button.

Figure 4-36. Lane Length Log

This log displays the lane length date for each lane number in the bowling center. The data is recorded in “tick counts”, which is the number of distance encoder ticks before the end of lane sensors is triggered for each lane. Refer to Figure 36.

The average, highest and lowest tick counts are displayed for each lane along with the actual value for the last three runs on that lane.

This information can show how consistent the recorded tick count is for each lane to indicate possible distance encoder or end of lane sensor maintenance. This information is only accurate if the operator verifies that they only run the same lane that is displayed on the current lane number on the center of the GUI.

The lane length will not be recorded in this log if the lane machine displays an error relating to the “tick count” or end-of-lane sensor. The most common cause for this type of error is a short (low) tick count caused by an operator pushing the lane machine beyond the foul line before pressing the start button. The lane length may need to be reset in the counter option of the maintenance screen to correct.

Section 5: Maintenance & Service

All machines need regular maintenance to stay in good working condition. The Authority22 was designed to make routine maintenance easy—parts are located where you can get to them and maintenance procedures are logical and simple to follow.

In this section you will find:

1. Checklist for daily maintenance
2. Checklist for weekly maintenance
3. Checklist for annual maintenance
4. Quick-List of “Counter” limits
5. Step-by-step instructions for replacing, servicing, and adjusting machine components

Before You Perform Any Maintenance

Before undertaking any maintenance, you should be familiar with the following Maintenance precautions and all of the Safety precautions noted in Section 1: Safety. In order to safely maintain this machine, you must be trained in the procedures in this manual, including the use of common mechanic’s hand tools and any special Brunswick tools. For clarification on any of this information, please contact your authorized Distributor or the Brunswick Customer Response Center (CRC) in the United States at 1-800-YES-BOWL, or internationally at 231-725-4966. For non emergency support, e-mail crcsupport@brunbowl.com

Always perform maintenance in an open area, away from lanes and approaches.

Daily Maintenance



WARNING!

Before performing maintenance, be sure the power cord is disconnected from both the machine and the wall outlet. Replace the protective sleeve and heat shrink tubing on the power cord if they become damaged.



WARNING!

Brunswick recommends using a partner whenever possible to help with lifting or lowering the machine from the operating position. Take care when lowering this machine into the operating position. Use proper lifting and lowering techniques, bend at the knees, and use a back support, if needed.

Refer to the Daily Maintenance Decal and Location information in Section 1, Figure 1-3.

Daily Maintenance in Operating Position

- (1) WASTE RECOVERY TANK
- (2) FRAME DIVISION WALL
- (3) DUSTER CLOTH SUPPLY ROLL
- (4) CLEANER SUPPLY TANK
- (5) CONDITIONER TANK
- (6) BUFFER BRUSH GUARD
- (7) FILTERS
- (8) PUMPS
- (9) TOP COVERS
- (10) REAR COVER
- (11) SIDE COVERS

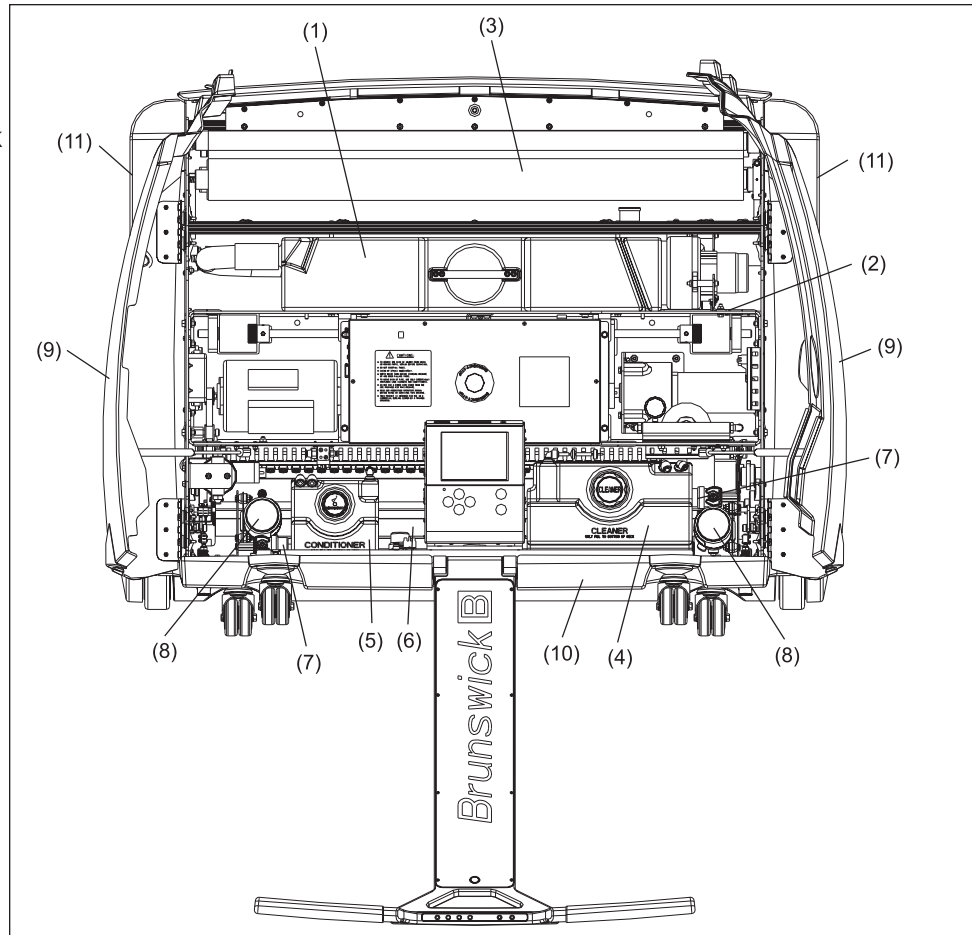

Figure 5-1. Operating Position - Daily Maintenance

1. Empty waste recovery tank, after each use, and wipe with a dry cloth. Remove the waste tank from the machine and dispose of the used lane machine waste properly. Do NOT dump recovery tank in a septic tank or sanitary sewer system. Follow your local environmental regulations for the best method of disposal.



CAUTION!

You must empty the waste recover tank before transporting the machine. Remove the waste tank from the machine and dispose of the used lane machine waste properly. Do NOT dump recovery tank in a septic tank or sanitary sewer system. Follow your local environmental regulations for the best method of disposal.

2. Wipe frame division wall.
3. Check duster cloth supply roll and replace if needed.
4. Fill cleaner supply tank.
 - a. Remove cap from cleaning tank, remove cap on end of the fill tube, located on the cleaner mixing vessel, and insert fill tube into cleaning tank.



CAUTION!

Use only Brunswick approved cleaning fluids.

- b. Press and hold button on container until cleaner nears the bottom of the tank neck. Do not fill into the neck of the tank.
- c. Release button and let cleaner remaining in tube drain into tank before replacing the cap on the end of the fill tube.
- d. Wipe any drips that collect in the depressed area around the outside of the tank neck.



WARNING!

Fill and empty tanks with the machine in operating position and away from lanes and approaches. Use the no-spill containers to avoid spilling. Clean all spills and drips immediately.

5. Fill conditioner supply tank.



NOTE:

The no-spill spout in the spare parts kit should fit onto the conditioner container.

- a. Remove cap from conditioner tank, remove cap on end of the fill tube located on the conditioner no-spill spout and insert fill tube into conditioner tank.



CAUTION!

Use only Brunswick approved conditioner fluids.

- b. Press and hold button on container until conditioner nears the bottom of the tank neck. Do not fill into the neck of the tank.
 - c. Release button and let conditioner remaining in tube drain into tank before replacing the cap on the end of the fill tube.
 - d. Wipe any drips that collect in the depressed area around the outside of the tank neck.
6. Wipe conditioning compartment including **buffer brush guard, filters, tanks, pumps and felt** with a dry cloth.



WARNING!

Take care when working around electrical connections to avoid damaging wire connections.

7. Wipe **top, rear and side** covers.

Daily Maintenance in Transport Position:

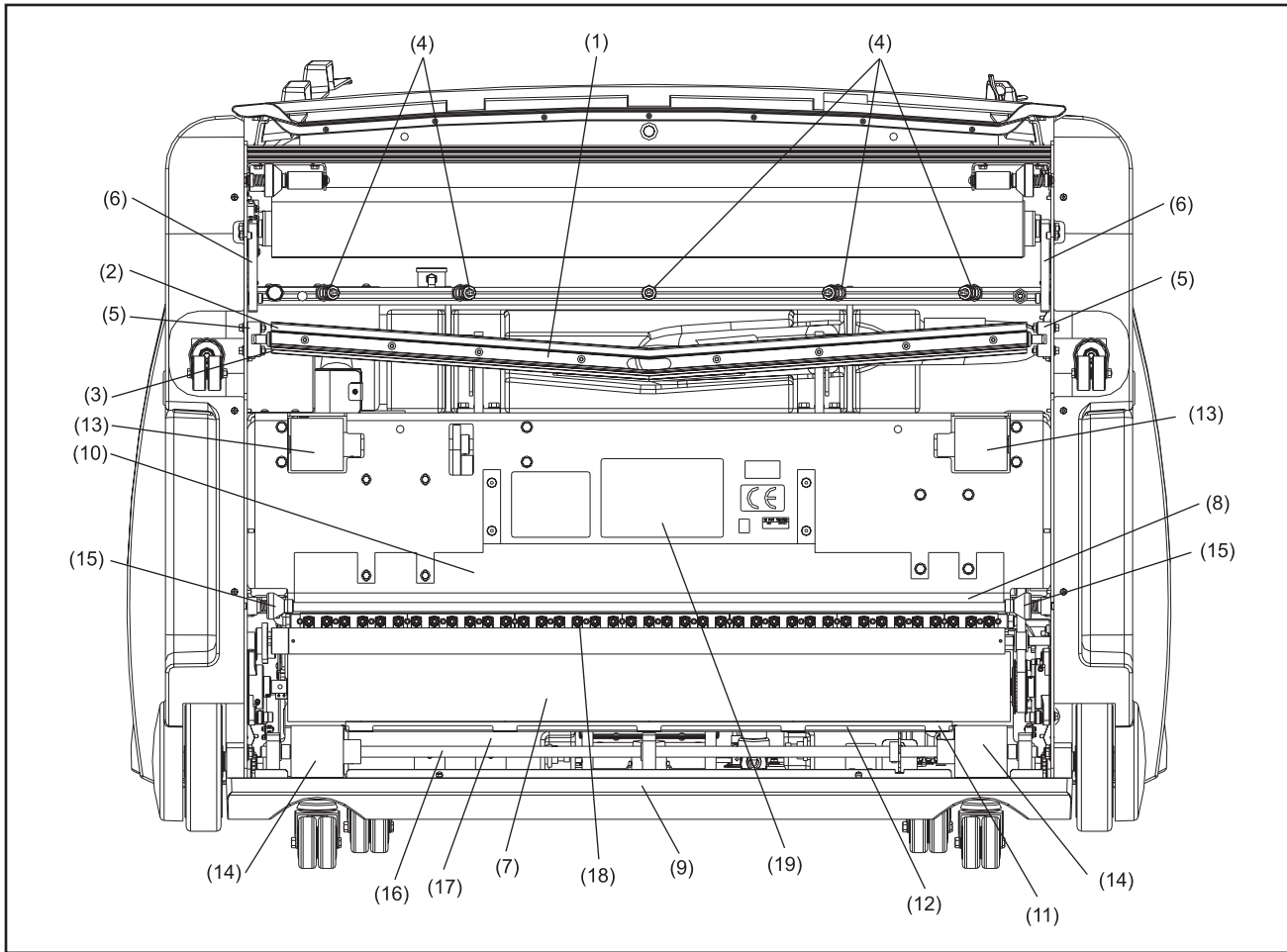

Figure 5-2. Transport Position - Daily Maintenance

- | | | |
|--|---|----------------------------------|
| (1) SQUEEGEE HEAD ASSEMBLY | (2) ABSORBENT WIPER | (3) SQUEEGEE BLADE |
| (4) CLEANER SPRAY NOZZLES | (5) SQUEEGEE ADJUSTMENT
GUIDE BLOCKS | (6) CONTACT ROLLER
PIVOT ARMS |
| (7) BUFFER BRUSH | (8) FRAME DIVISION WALL | (9) REAR WALL |
| (10) ABSORBENT FOAM IN FRONT
OF INJECTORS | (11) FOAM STRIP | (12) BUFFER BRUSH SHIELD |
| (13) TRACTION DRIVE WHEELS | (14) REAR WHEELS | (15) REAR GUIDE WHEELS |
| (16) REAR SHAFT AREA | (17) REAR FRAME AREA | (18) INJECTOR TIPS |
| (19) DAILY MAINTENANCE DECAL | | |

1. Wipe the entire **squeegee head assembly** including the **absorbent wiper** and **squeegee blade** with a dry terry cloth to remove dirt and moisture.
2. Wipe **cleaner spray nozzles**.
3. Wipe the **squeegee adjustment guide blocks** for the squeegee head assembly.
4. Wipe the **contact roller pivot arms**.

5. Wipe **buffer brush** area including **frame division wall**, **rear wall**, and **absorbent foam in front of injectors**.
6. Wipe bottom side of machine, including **traction drive**, **rear wheels**, **rear guide wheels**, **rear shaft**, and **rear frame area**.
7. Blot **injector tips** with a lint-free terry cloth.
8. Remove the **foam strip** from the lower edge of the buffer shield. Squeeze the conditioner from the foam strip by placing it between layers of a terry cloth towel and applying pressure. Do not twist or wring out the foam strip to avoid stretching or tearing it.
9. Wipe the inside surface of the buffer **brush shield** with a terry cloth towel.
10. Replace the dry foam strip over the retaining pins on the buffer shield. Make sure that the foam strip is pushed completely onto the base of the retaining pins so there is no gap between the surface of the buffer shield and the foam strip.
11. Replace the buffer shield foam strip with a replacement in the spare parts kit or order a new foam strip (reorder part number 14-100427-000) if it becomes torn, stretched or doesn't remain tightly attached to the buffer brush shield.



WARNING!

Always inspect approach areas and clean spills or drips immediately. Replace any loose foam.



NOTE:

The Daily Maintenance Decal on the bottom of the machine (refer to Figure 5-2) contains helpful reminders for each step explained above.

Weekly Maintenance

In addition to daily maintenance, these tasks should be done once a week, depending on use.



WARNING!

Before performing maintenance, be sure the power cord is disconnected from both the machine and the wall outlet. Replace the protective sleeve and heat shrink tubing on the power cord if they become damaged.

Weekly Maintenance in Operating Position

- (1) DUSTER CLUTCH ASSEMBLY
- (2) WASTE RECOVERY TANK

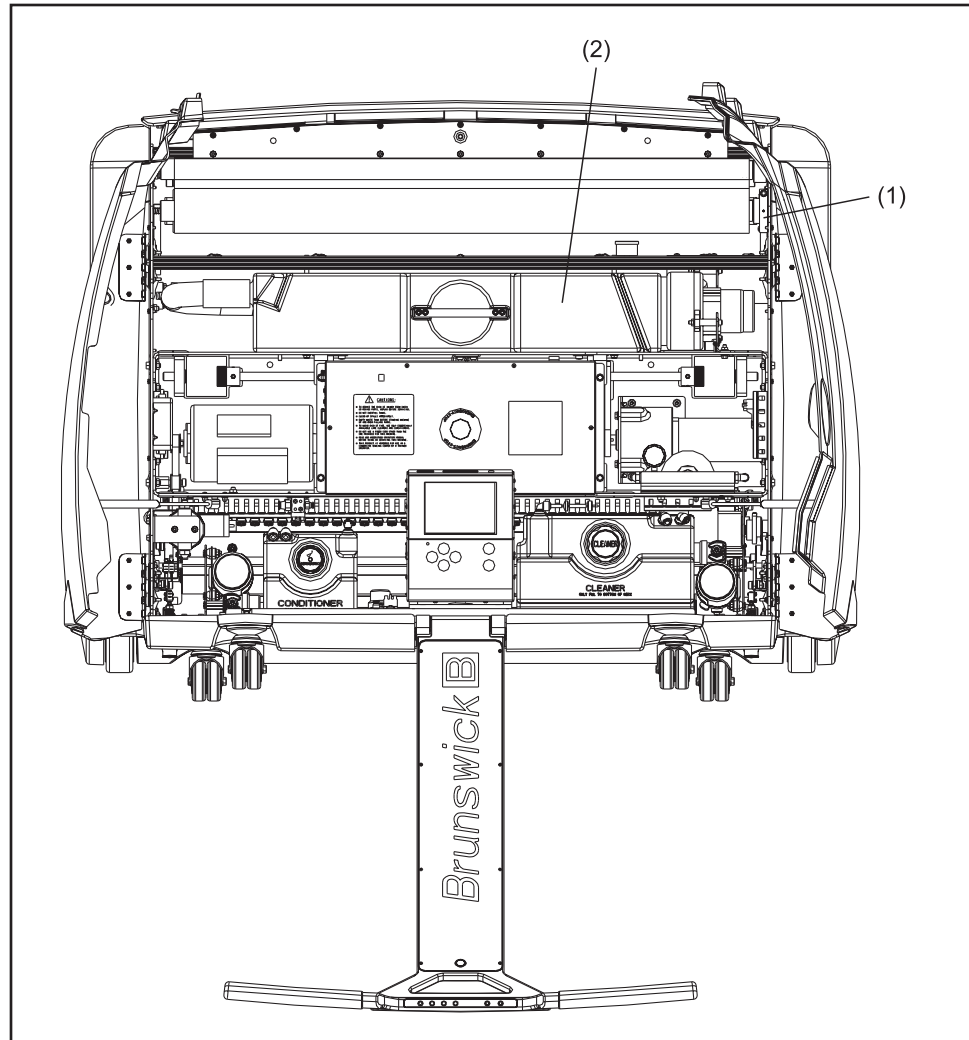

Figure 5-3. Operating Position - Weekly Maintenance

1. Check the tension setting on **duster clutch assembly**.

For more information go to the **adjusting the duster clutch** section.

2. Rinse waste **recovery tank**.
3. Inspect all **electrical connections** for loose or damaged wires.

Weekly Maintenance in Transport Position

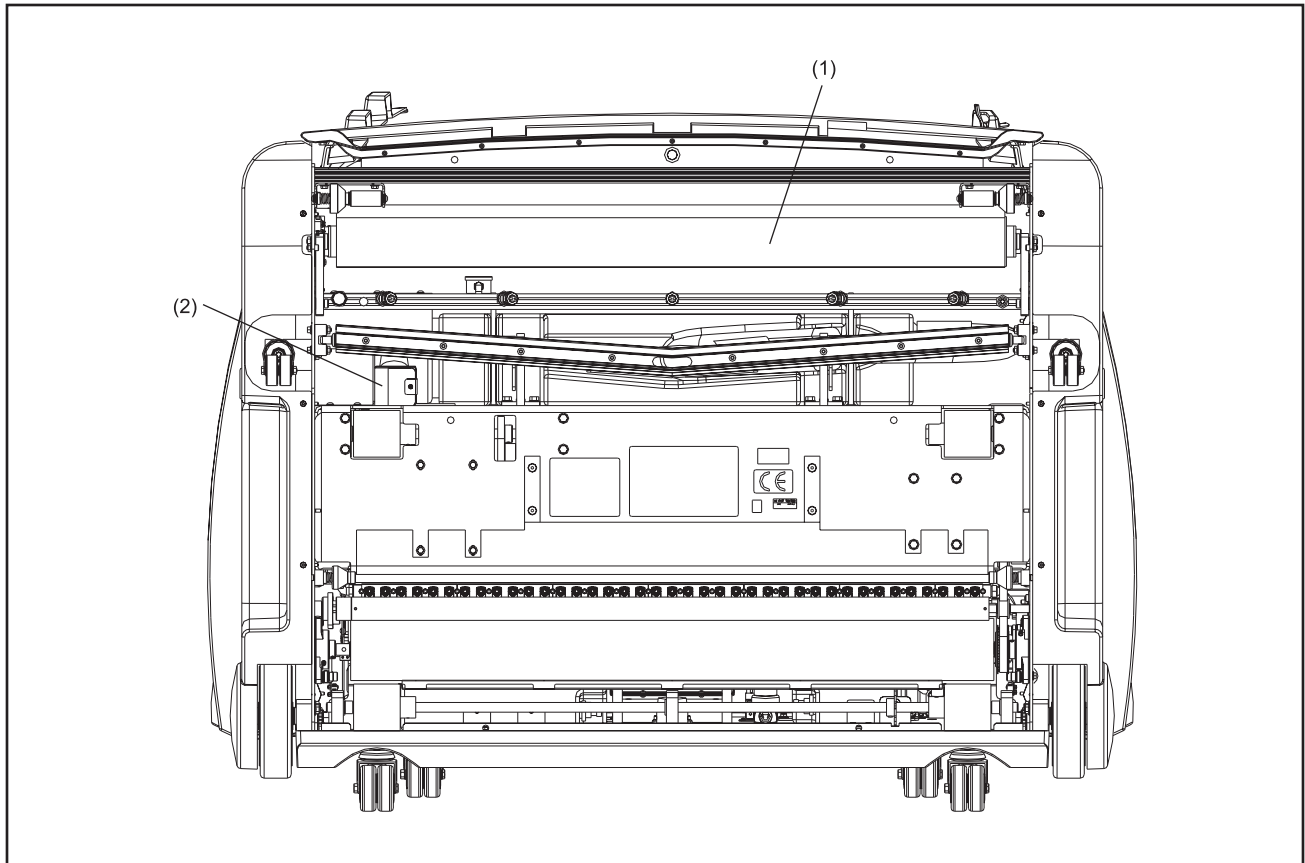

Figure 5-4. Transport Position - Weekly Maintenance

(1) DUSTER CLOTH CONTACT ROLLER (2) VACUUM EXHAUST DEFLECTOR

1. Wipe duster contact roller with a dry cloth.
2. Remove and squeeze out the absorbent foam material inside the vacuum exhaust deflector.
3. Check the absorbent wiper on the front of the squeegee blade. Flip the direction of bend every 1 to 3 months (5000 lanes) and replace every 3 to 6 months or sooner if it becomes damaged.



WARNING!

Brunswick recommends using a partner whenever possible to help with lifting or lowering the machine from the operating position. Take care when lowering this machine into the operating position. Use proper lifting and lowering techniques, bend at the knees, and use a back support, if needed.

Annual Maintenance

In addition to the daily and weekly maintenance, these items should be done once a year, depending on use. The Authority22 uses high-quality parts to ensure long life. Yet with the demands of daily use, you'll want to replace parts that wear and check the adjustment of other components to keep your machine in peak working order.

Wear on your machine is directly related to the amount of use and quality of preventative maintenance. Your replacement needs may be higher or lower than the guidelines given here. If you have questions about maintaining your machine, please contact your authorized Distributor or the Brunswick Customer Response Center (CRC) in the United States at 1-800-YES-BOWL, or internationally at 231-725-4966. For non emergency support, e-mail crcsupport@brunbowl.com



WARNING!

Before performing maintenance, be sure the power cord is disconnected from both the machine and the wall outlet. Replace the protective sleeve and heat shrink tubing on the power cord if they become damaged.

Annual Maintenance in Operating Position

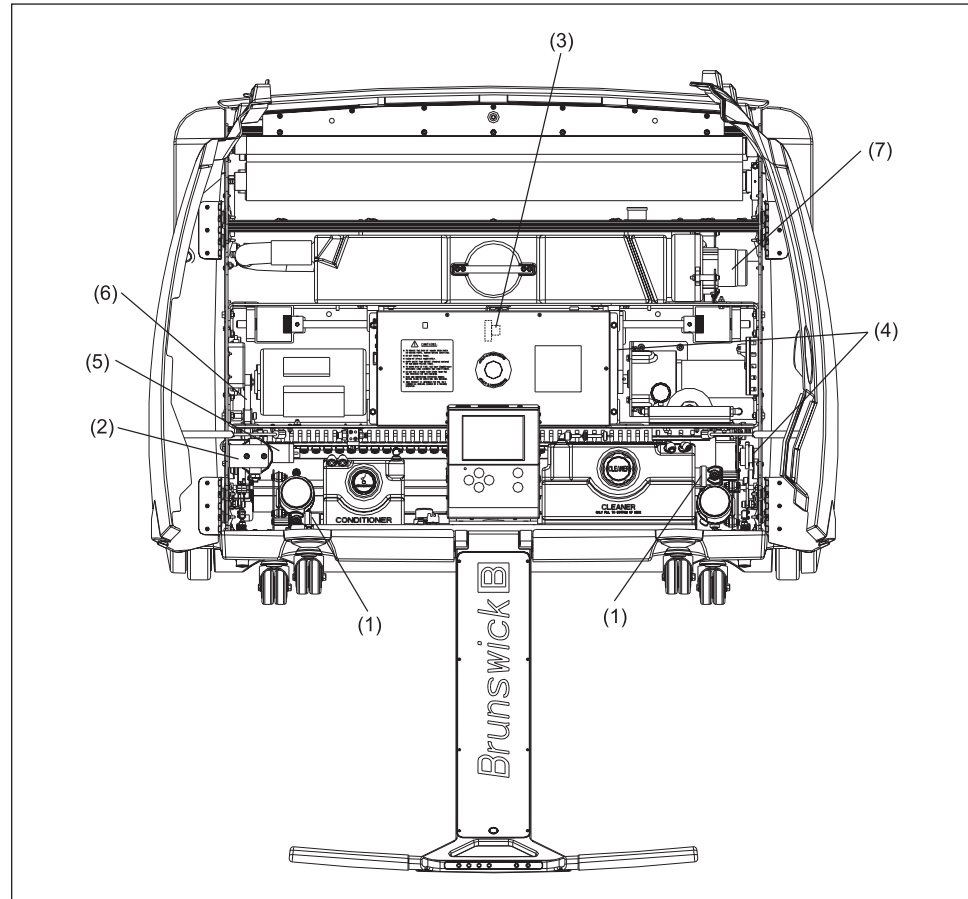

Figure 5-5. Operating Position - Annual Maintenance

- | | | |
|--|--------------------------------|----------------------------------|
| (1) CLEANER/CONDITIONER
SCREEN FILTERS | (2) CONDITIONER SPIN-ON FILTER | (3) SQUEEGEE LIFTING
ASSEMBLY |
| (4) TRACTION DRIVE/DISPERSION
ROLLER CHAINS | (5) BUFFER LIFTING ASSEMBLY | (6) BUFFER DRIVE BELT |
| (7) VACUUM MOTOR ASSEMBLY | | |



NOTE:

*The following procedures are explained in detail next, in the **How to Replace, Adjust, or Lubricate Parts** portion.*

1. Clean or replace in-line **cleaner**, and **conditioner screen filters**.
2. Replace **conditioner spin-on filter**.
3. Lubricate **squeegee lifting assembly**.
4. Lubricate **traction drive chain** and **dispersion roller chain**.
5. Lubricate **buffer lifting assembly**.
6. Inspect **buffer drive belt**, check tension and adjust if needed.
7. Inspect all fittings and tubing for damage and replace if needed.
8. Inspect all electrical connections and repair or replace if needed.
9. Inspect **vacuum motor assembly**, clean and replace if needed.



WARNING!

Before performing maintenance, be sure the power cord is disconnected from both the machine and the wall outlet. Replace the protective sleeve and heat shrink tubing on the power cord if they become damaged.



WARNING!

Brunswick recommends using a partner whenever possible to help with lifting or lowering the machine from the operating position. Take care when lowering this machine into the operating position. Use proper lifting and lowering techniques, bend at the knees, and use a back support, if needed.

Annual Maintenance in Transport Position

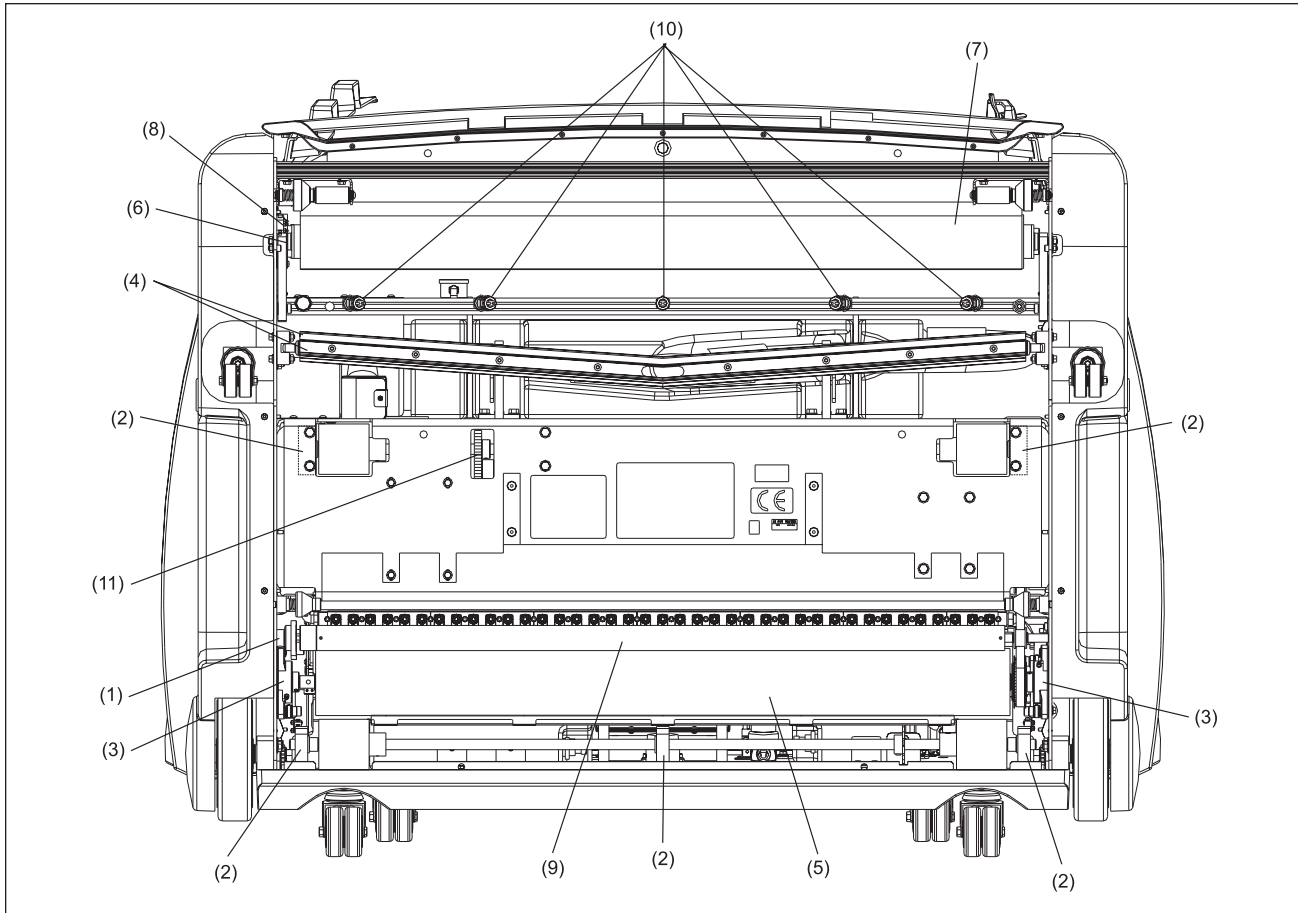

Figure 5-6. Transport Position - Annual Maintenance

- | | | |
|---|---|-------------------------------|
| (1) DISPERSION ROLLER
(GREASE LOCATION) | (2) REAR WHEEL/TRACTION DRIVE
BEARING BLOCKS | (3) BUFFER BRUSH
BEARINGS |
| (4) ABSORBENT WIPER AND
SQUEEGEE BLADE | (5) BUFFER BRUSH | (6) DUSTER CLUTCH
ASSEMBLY |
| (7) DUSTER CONTACT ROLLER | (8) DUSTER UP/DOWN SWITCHES | (9) DISPERSION ROLLER |
| (10) CLEANER SPRAY NOZZLES
AND CHECK VALVE FILTERS | (11) TRACTION DRIVE CHAIN | |



NOTE:

The following procedures are explained in detail next, in the *How to Replace, Adjust, or Lubricate Parts* portion.

1. Grease **dispersion roller**.
2. Lubricate **rear-wheel bearing blocks and traction drive bearing blocks**.
3. Grease **buffer brush bearings**.
4. Replace **absorbent wiper** (flip every 1 to 3 months (5000 lanes) and replace every 6 months) and **squeegee blade** (flip every 3 to 6 months, replace every 12 months). You may need to replace them sooner depending on the usage of the machine

5. Inspect **buffer brush** and replace if needed.
6. Inspect **duster clutch assembly** and **hardware** and replace if needed.
7. Inspect **duster contact roller** for chunks, dents, or brittleness and inspect **hardware** for wear and replace as needed.
8. Inspect **duster up/down switches** for damage and replace if needed.
9. Inspect **dispersion roller** for damage, check chain tension and repair, replace, or adjust if needed.
10. Remove **cleaner spray nozzles** and **check valve filters**. Clean all by soaking in a distilled white vinegar for 30 minutes, rinse with warm water and blow out with compressed air.



WARNING!

Wear safety glasses when using compressed air. Place a cloth under the spray tip assembly to absorb residual fluid that may drip when removing tips.

11. Inspect **traction drive chain** alignment and tension and adjust if needed.

GUI Maintenance Messages

The GUI will generate *Warning* messages when counters expire for specific components listed in the “Diagnostics - Counters”. Each component has an expected “life” it should achieve before it should be replaced. Keep in mind that lanes with surface issues and environments that are very dirty can accelerate wear. For each lane that is run, once a counter has expired, the GUI will display the warning message until the component is replaced or cleaned, and the counter is reset. The warning message will always appear “*Warning: A hardware counter has expired...*” Refer to Figure 5-7.

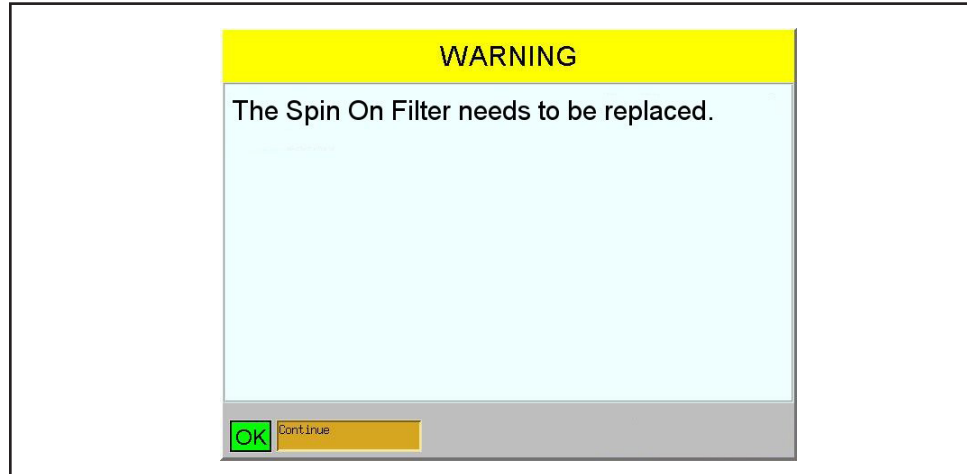

Figure 5-7. GUI Maintenance Messages

Below is a list of all the counters and the expected life (in lanes or in hours) for each component monitored by the GUI. Refer to *Section 4 - Maintenance Counters* for instructions on resetting a counter.



NOTE:

The Spin-on filter is recommended to be replaced after 29,200 lanes; however, it should also be replaced whenever switching brands of lane conditioner.



NOTE:

Inspect and rotate the squeegee absorbent wipe and urethane blade to place the opposite edge in use every 3 months or 5,000 lanes. Replace if needed.

Quick-list of Maintenance Counters

Buffer Lanes	29,200 lanes
Squeegee Lanes	14,600 lanes
Duster Lanes	700 lanes
Oil Filter Lanes	29,200 lanes
Cleaner Filters Lanes	29,200 lanes
Spin-On Filter Lanes	29,200 lanes
Absorbent Wiper Lanes	5000 lanes
Drive Motor Hours	5000 hours
Vacuum Motor Hours	500 hours
Lane Length	As needed

How to Replace, Adjust, or Lubricate Parts

The Cleaning System

Using the Squeegee/Buffer Adjustment Tool

The Authority22 is equipped with its own adjustment tool for measuring the height of the squeegee and the buffer brush. The adjustment tool is mounted inside the lane machine between the electronic enclosure and the center compartment wall separating the cleaning section from the center compartment. It is fastened by two wing nuts. Refer to Figure 5-8. The adjustment tool has three notches used to verify adjustments. The squeegee uses the 1/8" notch only while the buffer brush may use all three notches (1/8", 3/16", and 1/4"). To properly use the Squeegee/Buffer Brush adjustment tool, position so it spans the rear shaft wheel and the traction drive wheel on one side of the machine and then the opposite side. The notches should align with the squeegee and buffer brush so they are spanning the assembly. Refer to Figure 5-9.

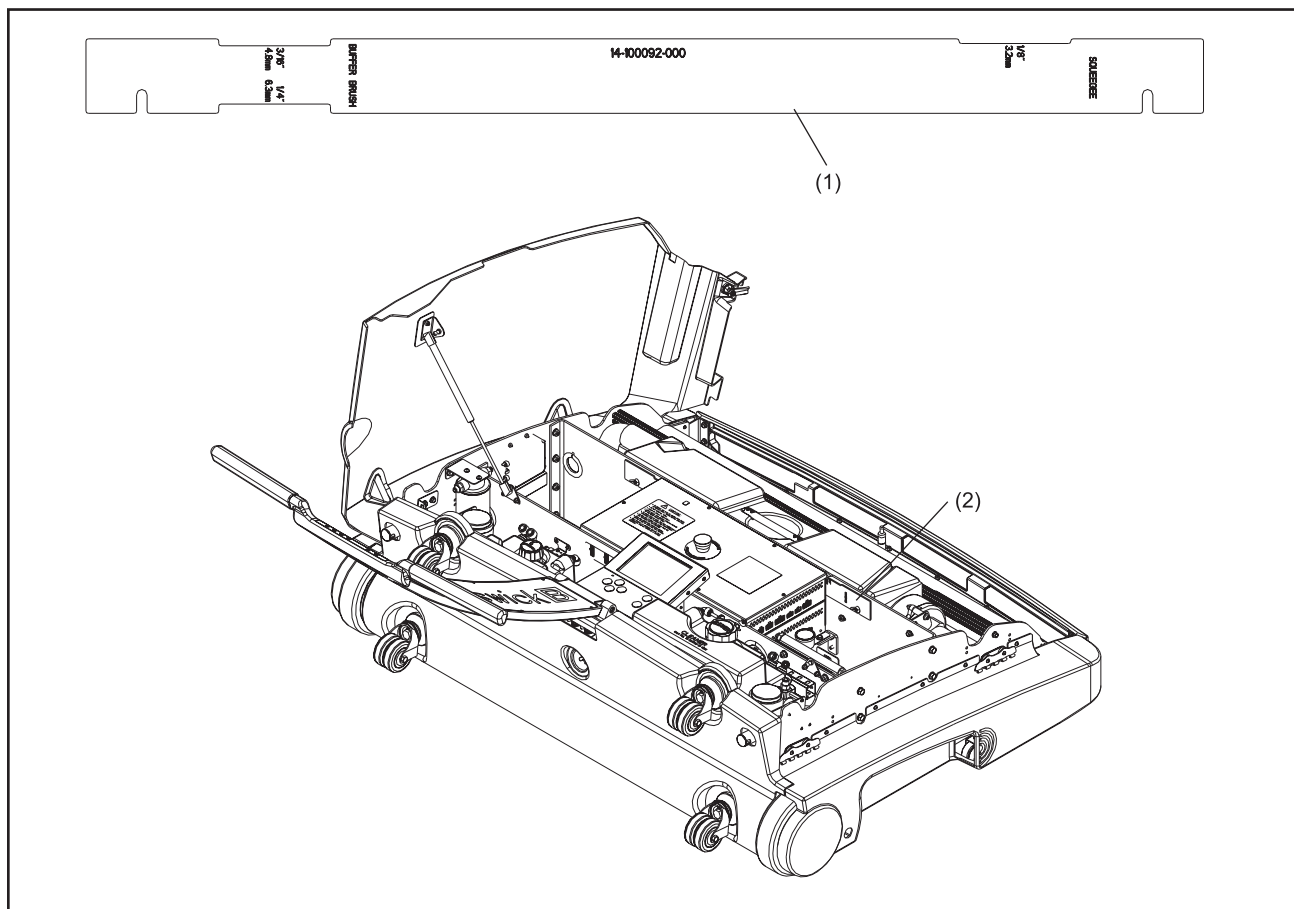

Figure 5-8. Adjustment Tool Storage Location

- (1) SQUEEGEE/BUFFER ADJUSTMENT TOOL (2) ADJUSTMENT TOOL STORAGE LOCATION

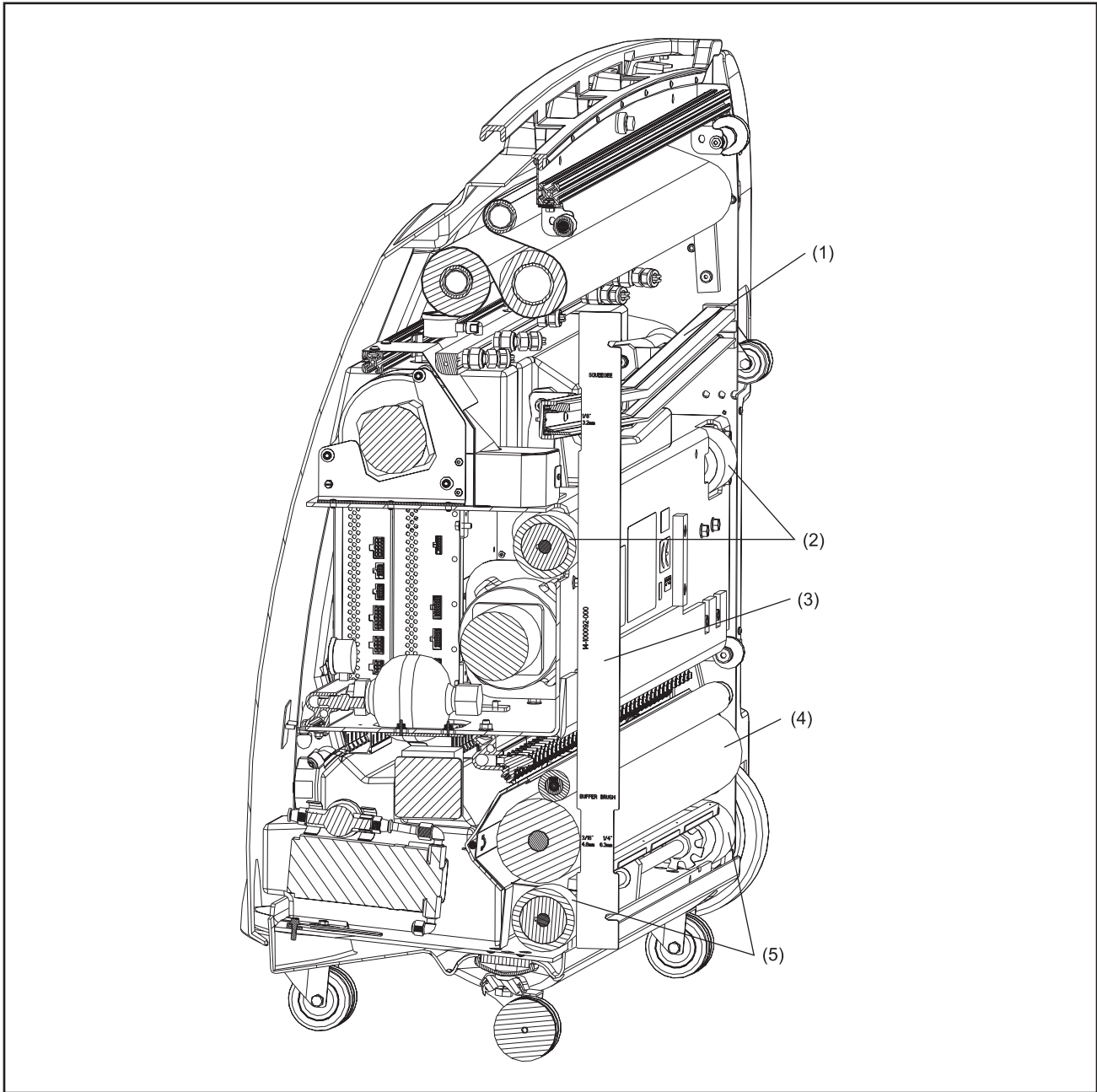

Figure 5-9. Using the Adjustment Tool - Section View

- | | | |
|----------------------------|-----------------------|-------------------------------------|
| (1) SQUEEGEE HEAD ASSEMBLY | (2) TRACTION WHEELS | (3) SQUEEGEE/BUFFER ADJUSTMENT TOOL |
| (4) BUFFER BRUSH | (5) REAR SHAFT WHEELS | |



NOTE:

*Refer to the **Adjusting the squeegee blade height** and **Adjusting the buffer brush height** in this section.*

Replacing the Duster Cloth

Parts needed: new duster cloth supply roll:

1. With the machine on the approach and in the Operating Position, open the covers.
2. Grasp the lower duster cloth take-up roll (the full one in front) and push it to your right to compress the spring loaded hub.
3. Lift the duster cloth take-up roll towards you and remove from the lane machine.
4. Tip the duster cloth take-up roll to allow the metal stiffener tube to slide out of the duster cloth take-up roll core. Set the metal stiffener tube aside and dispose of the duster cloth take-up roll and core.
5. Remove the empty duster cloth supply roll core from the top position by following the same process as in 2 & 3 above. Keep the metal stiffener tube with the empty duster cloth supply roll core.
6. Insert the metal stiffener tube from the duster cloth take-up roll core into the new supply roll core and install the new duster cloth supply roll in the upper supply roll position on the machine.
7. Unwind several feet of cloth and route it through the duster system as shown on the routing decal. This decal should be located on the left side wall of the machine (7 pin side) in the area of the supply roll hub.
8. Drape the loose end of the duster supply cloth over the top of the waste recovery tank and onto the electronics enclosure.
9. Remove the paper backing from the unused strip of double sided tape on the old duster cloth supply core.
10. Lay the core, adhesive side down, across the duster supply cloth between the waste recovery tank and the electronics enclosure. Care should be taken to keep the core at a straight 90 degree angle to the cloth.
11. Wind the duster cloth over the top of the old duster cloth supply core as shown on the routing decal.
12. With at least two full winds on the old duster cloth supply core, install it into the lower, duster cloth take-up roll position in the front of the machine.

13. From the Operators screen, use the left/right arrows to highlight the Change Duster Cloth button in the lower, center of the screen and press OK.
14. The GUI will prompt you on how to correctly wind up the slack duster cloth. This process will also automatically reset the duster cloth counter in the maintenance screen.
15. Close the covers and resume operation of the machine.

Adjusting the Duster Clutch

Tools needed: 1/4" Allen wrench (part number 11-112132-000, included in the spare parts package):

1. Lower the duster cloth using the “duster unwind” button in the GUI diagnostics for cleaning, then wind the cloth up, using the “duster wind” button. The motor should lift the duster contact roller to its raised position and then advance ~1/2" of new cloth.
2. Once the motor quits turning, the clutch on the duster cloth supply roll and duster motor on the duster cloth take-up roller should maintain their position. Press down firmly on the raised duster contact roller with the fingertips of both hands to check for proper adjustment of the duster clutch.
3. If the duster contact roller does not remain in the raised position after trying to press it down, the duster clutch assembly needs to be tightened. To increase torque, use the supplied 1/4" Allen wrench to turn the adjustment bolt clockwise in the duster clutch assembly.
4. Next, check to make sure that the duster clutch is not tightened too tightly to advance new duster cloth. Lower the duster cloth using the “duster unwind” button in the GUI diagnostics for cleaning, then wind the duster cloth up, using the “duster wind” button. (The load on the duster cloth motor should increase and turn more slowly when the supply roller turns, causing the duster clutch to slip.)
5. If the duster cloth motor stalls before it advances new duster cloth or if it reverses direction or “back lashes” after the duster cloth motor stops turning, there is too much torque on the duster clutch assembly. To decrease torque, use the supplied 1/4" Allen wrench to turn the adjustment bolt counterclockwise in the duster clutch assembly. *Tip: The spring on the duster clutch adjustment bolt may cause unpredictable results after turning it counterclockwise. Instead of turning bolt 1/8 turn counterclockwise, turn bolt 1/4 counterclockwise followed by 1/8 turn clockwise.*
6. Repeat steps 1-5 to verify the proper duster clutch adjustment.

Adjusting the Down Stop for the Duster Contact Roller Pivot-Arm

Tools needed: 3/16" allen wrench, 7/16" Open-end wrench:

Refer to Figure 5-10.

- (1) DUSTER CONTACT ROLLER
DOWN STOP BOLT
- (2) DUSTER CONTACT ROLLER PIVOT ARM
- (3) DUSTER UP SWITCH
- (4) DUSTER DOWN SWITCH

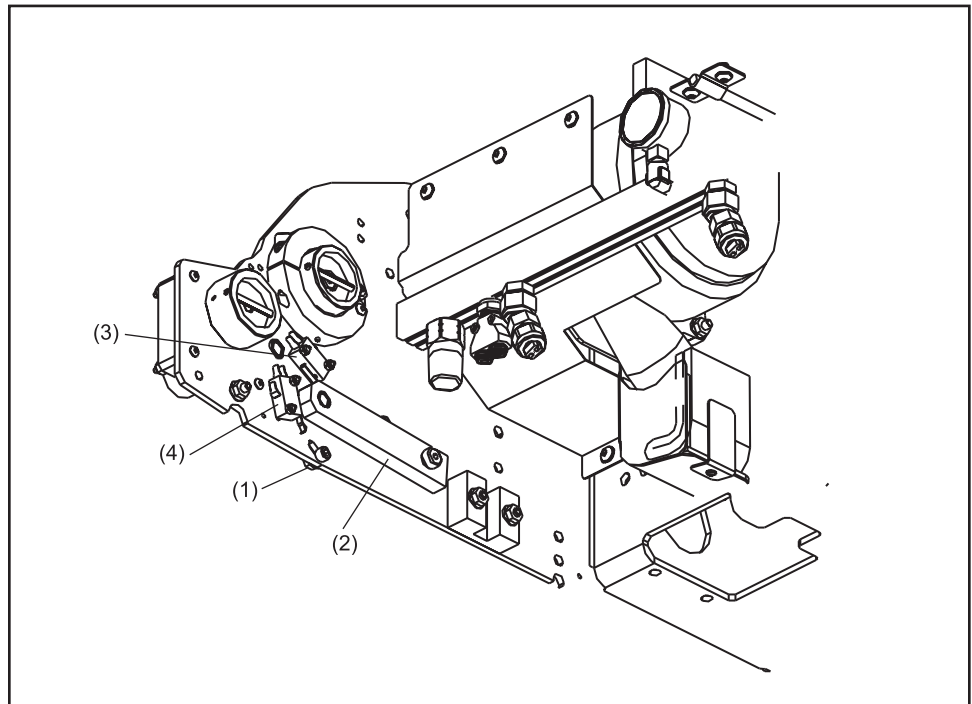

Figure 5-10. Adjusting Down Stop - Bottom View

1. Place the machine in transport position with the power supply disconnected.
2. Locate the duster contact roller down stop bolt below the pivot arm of the contact roller.
3. Loosen the bolt using a 3/16" allen wrench and 7/16" open-end wrench and move the stop bolt up or down in the slotted hole to adjust the position of the stop. The stop bolt should be located in the center of the adjustment slot on both the 7 and 10-pin sides.

Replacing the Duster Up/Down Switches

Tools needed: 1/8" allen wrench, 1/16" allen wrench, 1/4" open-end wrench.

Parts needed: duster up or down switch (Part Number 11-616025-000).

Refer to Figure 5-9.

1. Place the machine in transport position with the power supply disconnected and open the cover.
2. Remove the side cover on the 10-pin side of the machine by removing the 3 screws on the bottom side and the 5 screws on the top inside using a 1/8" Allen wrench.
3. Identify the faulty switch.
 - a. The duster "up" switch is in a fixed position, up and behind the duster contact roller when the machine is in transport position.
 - b. The duster "down" switch is mounted in an adjustable slot and is visible from below the duster contact roller.
4. Move the duster cloth out of the way in order to access the switches.
5. Remove the duster up/down switch by removing the 2 mounting screws with the 1/4" wrench and 1/16" allen wrench and disconnecting the wires from the fast-on connectors.
6. Transfer the wires from the old duster up/down switch to the new switch.
7. Replace wires following the same wiring pattern as the original switch:
 - a. Up switch wiring: white = common, green = n.o. (normally open).
 - b. Down switch wiring: blue = common, brown = n.o. (normally open).
8. Remount duster up/down switch.
9. Verify the placement of the duster down switch.
 - a. The switch should begin to engage when the contact roller pivot arm is contacting the down stop.



NOTE:

The duster down switch should indicate the down position in the cleaner diagnostics when the duster cloth motor is lowered with the lane machine in the operating position on the approach, when it is resting against the down stop for the contact roller pivot arm. When the lane machine is pushed on the front of the lane, the lane should push the contact roller up slightly so the duster down switch is no longer engaged.

- b. Loosen the screw and adjust the position of the switch until it is correct.
10. Replace duster cloth.
11. Replace side cover.

Adjusting the Squeegee Blade Height

Tools needed: Buffer/Squeegee adjustment tool, 10" #2 Phillips screwdriver.
(Part Number 11-112133-000 included with spare parts package).

Adjustment: 1/8" notch on buffer/squeegee adjustment tool.

Refer to Figure 5-11.

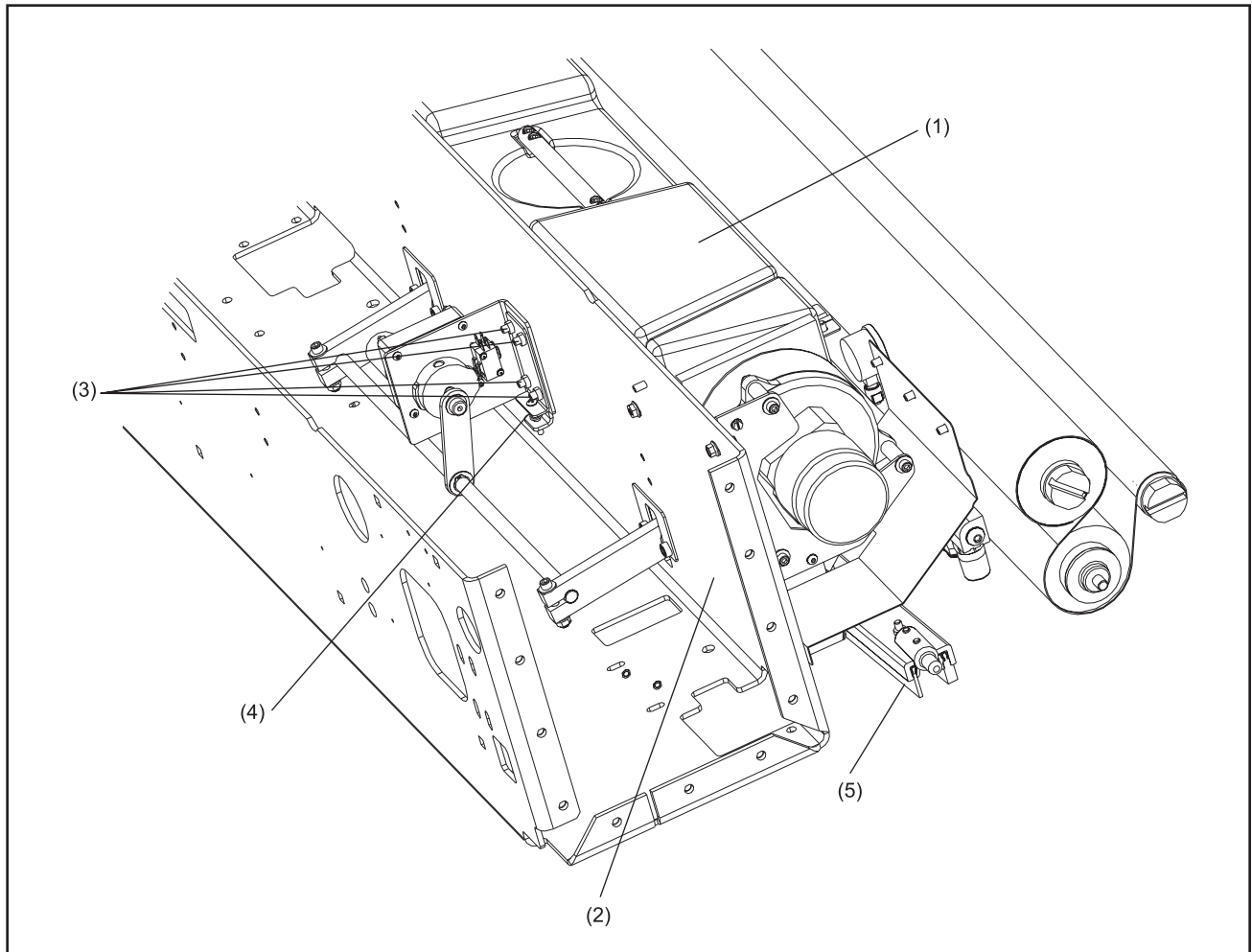

Figure 5-11. Adjusting Squeegee Blade Height

- | | | |
|---------------------------|-------------------------------|---------------------|
| (1) WASTE RECOVERY TANK | (2) FRONT FRAME DIVISION WALL | (3) FLAT HEAD BOLTS |
| (4) PLATE ADJUSTING SCREW | (5) SQUEEGEE BLADE | |

1. Place machine in operating position covers open and the power supply on.
2. Go to the “Cleaner Diagnostics” screen in the “Maintenance” menu of the GUI.
3. Lower the squeegee head so the sensor shows the squeegee is down.
4. Disconnect power from the machine.

5. Lift the machine into the transport position and measure the height adjustment using the buffer/squeegee adjustment tool for the initial appropriate adjustment. (refer to the beginning of this section “Using the buffer/squeegee adjustment tool”).
6. If an adjustment is needed open the covers and remove the waste tank, loosen but do not remove the 4 flat head bolts on the front frame division wall of the machine.
7. Using the 10" Phillips screwdriver on the plate adjusting screw, raise or lower the adjusting plate so the front edge of the blade contacts the lane surface. Turning the adjustment screw clockwise will lower the squeegee blade while turning the screw counter clockwise will raise the squeegee blade.
 - a. If it's too high, the bottom of the squeegee blade will not contact the 1/8" notch surface of the buffer/squeegee adjustment tool.
 - b. If it's too low, the front face of the squeegee blade will contact the 1/8" notch surface of the buffer/squeegee adjustment tool with some deflection of the blade.
8. Tighten the 4 flat head bolts.
9. Lower the lane machine into the operator position and open covers.
10. Place the machine on the lane surface.
11. Visually check the squeegee for even deflection away from the vacuum head. If the squeegee blade is not evenly deflected from side to side, loosen the two bolts on one of the squeegee are pivots on the front frame division wall. Adjust the pivot up or down for even side-to-side deflection of the squeegee blade and then tighten the pivots bolts.
12. The squeegee blade needs a 45-degree angle of deflection across the entire squeegee blade. If an adjustment is needed, restore power to the machine and use the cleaner diagnostic screen to raise the squeegee. Loosen, but do not remove, the 4 flat head bolts on the front frame division wall of the machine.
13. Using the 10" Phillips screwdriver on the plate adjusting screw, raise or lower the adjusting plate so the front edge of the blade contacts the lane surface at about a 45 degree angle. Lower the squeegee and push the machine forward on the lane.
 - a. If it's too high, the bottom of the squeegee blade will just contact the lane surface with very little deflection.
 - b. If it's too low, the front face of the squeegee blade will contact the lane surface with too much deflection (~90 degree angle).

14. Tighten the 4 flat head bolts.
15. Replace the waste recovery tank.
16. Test clean the lane.

Adjusting the Squeegee Blade Pitch

Tools needed: 3/8" open-end wrench, 7/16" open-end wrench.

Adjustment: slightly forward from center of the adjustment slot.

Refer to Figure 5-12.

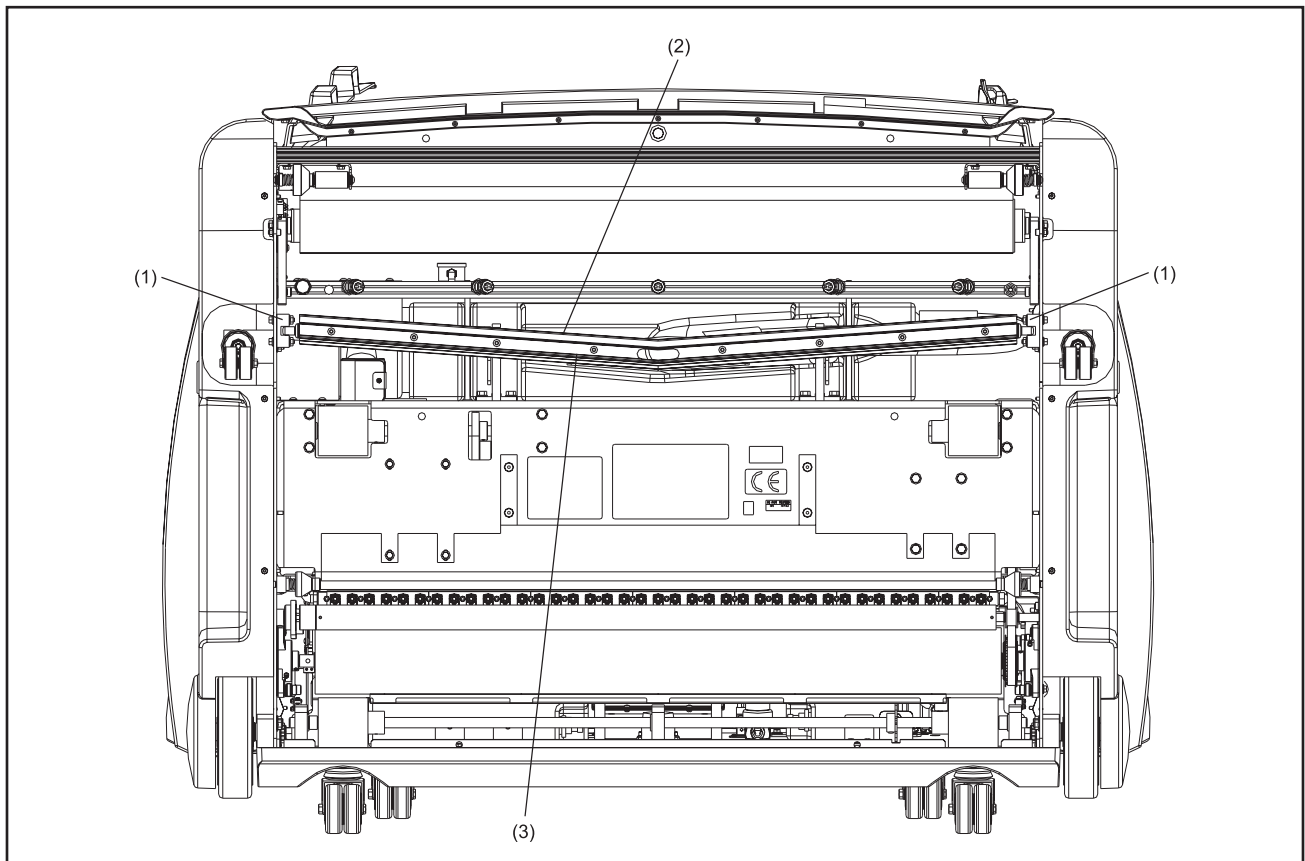

Figure 5-12. Adjusting Squeegee Blade Pitch

(1) SQUEEGEE ADJUSTMENT
GUIDE BLOCKS

(2) ABSORBENT WIPER

(3) SQUEEGEE BLADE

1. Place machine in operating position covers open and the power supply on.
2. Go to the “Cleaner Diagnostics” screen in the “Maintenance” menu of the GUI.
3. Lower the squeegee head so the sensor shows the squeegee is down.
4. Disconnect power from the machine.

5. Loosen, but do not remove, the two mounting bolts for each the squeegee adjustment guide blocks on the 7 and 10-pin sides.
6. Adjust the guides.
 - a. Moving the guides towards the front of the machine forces more pressure on the center of the squeegee blade (for lane depressions).
 - b. Moving the guide blocks towards the rear of the machine releases pressure from the center of the squeegee blade (for crowning lanes) and applies more pressure to the absorbent wiper.
7. Tighten the bolts for the squeegee adjustment guide blocks. Verify the squeegee has some play to pivot forward and backward and is not binding in the guide blocks.
8. Remove the cleaner waste recovery tank.
9. Place the machine on the lane surface.
10. Visually check the squeegee for even deflection away from the vacuum head.



NOTE:

It may be necessary to perform the squeegee height adjustment after making the pitch adjustment.

11. Replace the waste tank.
12. Restore power to the machine and test clean the lane.

Replacing the Absorbent Wiper And Squeegee Blade

Refer to Figure 5-12.

Tools Needed:

- 3/16" Allen wrench
- 1/2" Open end wrench
- 5/32" Allen wrench

Parts Needed To Rotate Existing Absorbent Wiper or Squeegee

New Absorbent Wiper part number

14-100556-000 included with spare parts package.

New Squeegee Blade part number 14-100523-000

1. Put machine in transport position.
2. Open covers and remove cleaner waste recovery tank.
3. Remove the two shoulder pivot bolts for the squeegee head using 3/16" allen wrench and 1/2" wrench on hex nuts.

4. Take the vacuum head to a work table and remove the hose.
5. Remove all 8 button head cap screws with a 5/32" Allen wrench from inside the vacuum head and gently pry up the inner retaining channel and remove.
6. Remove and replace the absorbent wiper blade or rotate the blade depending on the blade usage.



NOTE: The absorbent wiper blade and the squeegee blade are designed to be flipped so that you receive at least two uses of each blade.

7. Check the squeegee blade for wear, flip and reuse, or replace as required.
8. Place the inner retaining channel in-between the absorbent wiper blade and the squeegee blade.
9. Using the screws removed in step #5 above (the inside end of each inner channel uses the shorter screw), start on the outside end and gently work the retaining channel down as you tighten the bolts.



NOTE: Make sure the retaining channel does not pull the blade down under the retainer. Both the absorbent wiper and squeegee blade should be straight across the width of the vacuum head after tightening.

10. Replace the hose and reinstall the squeegee head in the lift arms using the two shoulder type bolts.
11. Verify correct adjustment of the squeegee blade height per this manual.



NOTE: The wiper is two sided and after one side has reached the end of its useful life, rotate the wiper to place the opposite edge in use. Expected life is 1 – 3 months per side for a 40 lane bowling center; however, the wear is dependent on use and the condition of the lane surface.



NOTE: The squeegee blade is two sided and after one side has reached the end of its useful life, rotate the squeegee blade to place the opposite edge in use. Expected life is 3 – 6 months per side for a 40 lane bowling center; however, the wear is dependent on use and the condition of the lane surface.

Replacing the Squeegee Up/Down Switches

Tools needed: 1/16" allen wrench, 3/8" socket wrench with extension.

Parts needed: replacement switches (Part Number 11-616026-000).

Refer to Figure 5-13.

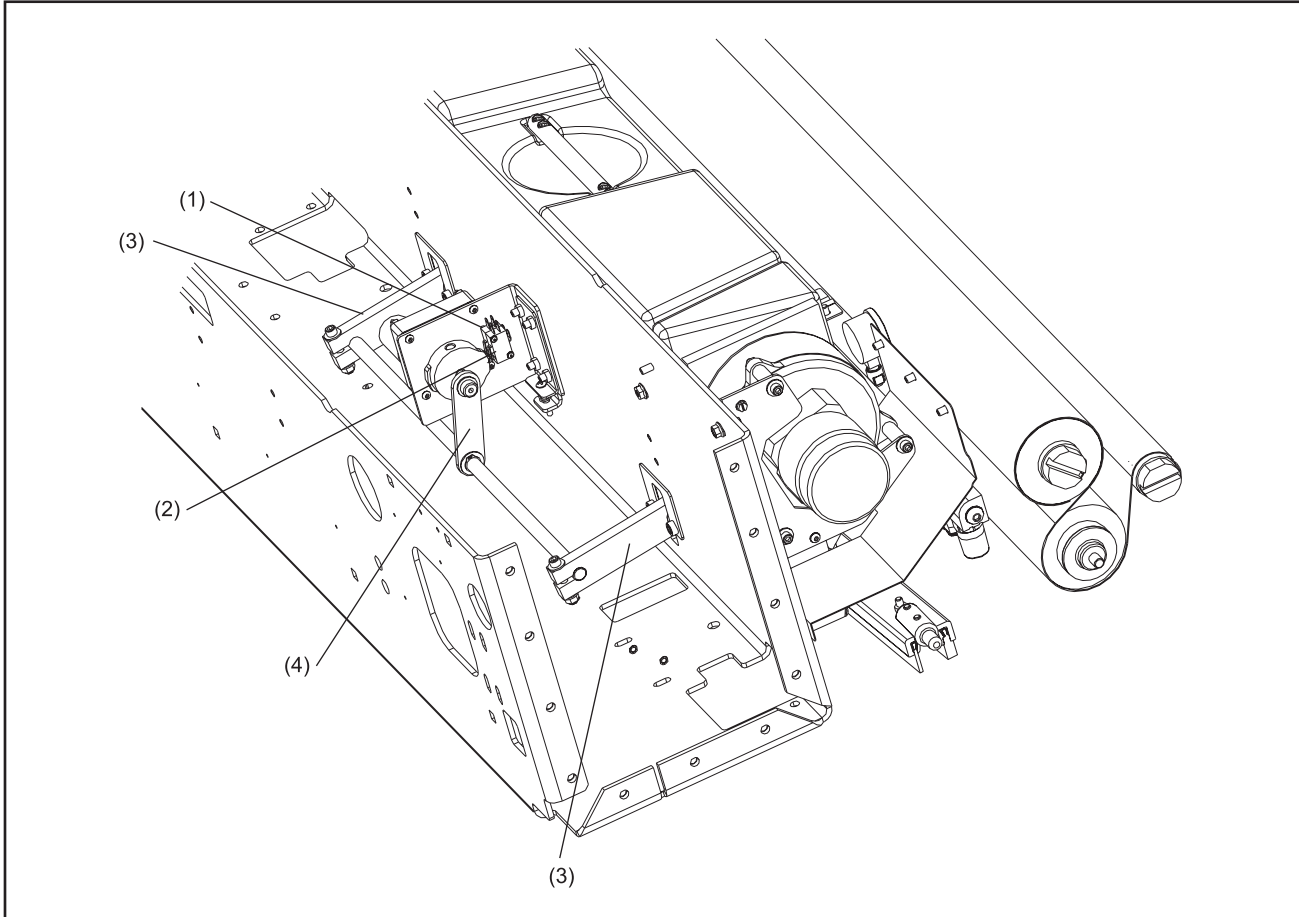

Figure 5-13. Replacing Squeegee Up/Down Switches

- | | | |
|------------------------------|--------------------------|-------------------------|
| (1) SQUEEGEE UP SWITCH | (2) SQUEEGEE DOWN SWITCH | (3) SQUEEGEE PIVOT ARMS |
| (4) SQUEEGEE LIFTING LINKAGE | | |

1. Place machine in operating position with the power supply disconnected and open the cover.
2. Remove the electronic enclosure and set aside using this process:
 - a. Disconnect all cables from the sides and rear of the enclosure.
 - b. Loosen and remove 4 bolts that secure electronic enclosure to mounting brackets.
 - c. Remove and set aside.



CAUTION!

Do not use emergency stop button as a handle to lift enclosure

3. Disconnect switch cables at connector plug, leaving the wires on the switches.
4. Remove the 2 screws that secure the switch to the mounting bracket using a 1/16" allen wrench.



NOTE:

The up/down switches are mounted back to back on the bracket and can be distinguished by the color of their wires; the “up” switch has green and white cables, the “down” switch has blue and black cables.

5. Remove switches.
6. Replace faulty switch.
7. Reconnect cables using the fast-on cable connectors.
8. Position switches on mounting bracket and replace and tighten screws that secure switches to the bracket.



NOTE:

Position switches as close to the cam as possible to ensure good contact with switches.

9. Connect Cable plug to harness.
10. Position the electronics enclosure in place, replace and tighten bolts that secure the electronic enclosure to mounting brackets, and reconnect all cables.

Lubricating the Squeegee Lifting Assembly

Refer to Figure 5-13.

1. Apply one drop of oil to each side of the bearings on the squeegee pivot arm.
2. Apply one drop of oil to the bearings on the squeegee lifting linkage connected to the cam for the lifting motor and to the shaft connecting both squeegee pivot arms.

Draining the Cleaner Supply Tank

Tools needed: None.

Parts needed: Drain tubing found in the spare parts kit, spare container.

Refer to Figure 5-14.

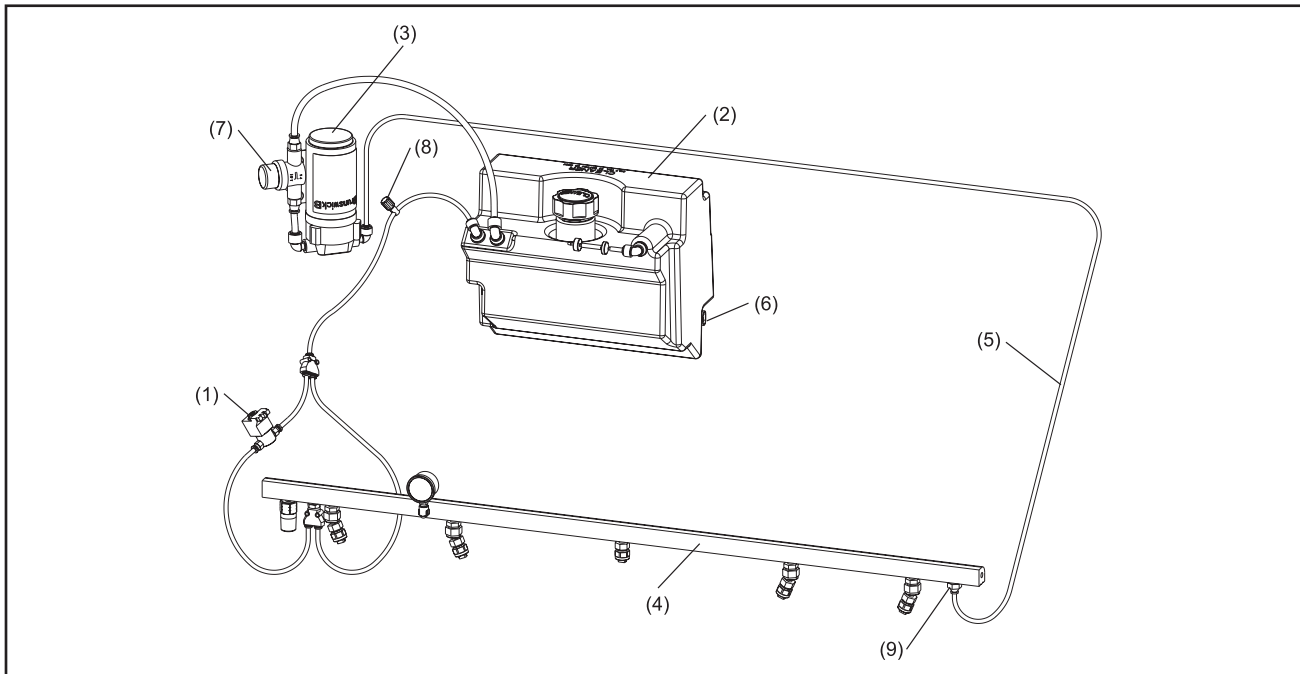

Figure 5-14. Draining the Cleaner Supply Tank

- | | | |
|---------------------------|-------------------------|-------------------------------------|
| (1) CLEANER BYPASS VALVE | (2) CLEANER SUPPLY TANK | (3) CLEANER PUMP |
| (4) CLEANER MANIFOLD | (5) SUPPLY TUBING | (6) CLEANER LEVEL
FLOAT SENSOR |
| (7) CLEANER SCREEN FILTER | (8) PINCH VALVE | (9) DISCONNECT TO USE
DRAIN TUBE |

1. Place the machine in the operator position and supply power.
2. Place a rag underneath the fitting on the 7-pin side of the cleaner manifold.
3. Remove the supply tubing from the 7-pin side of the cleaner manifold by depressing the retainer on the fitting and pulling the tubing out.
4. Attach the drain tubing with the 1/4" elbow union to the supply tubing removed in step 3.
5. Route the drain tubing into a container and hold in place.
6. Go to Cleaning Diagnostics and turn on the cleaner pump.
7. Continue to run pump until cleaner has been completely drained.
8. Remove the drain tubing and reconnect the supply line to the manifold.



IMPORTANT!:

It is very important to make sure the tubing is not damaged and that it is inserted completely into the fitting

Replacing the Level Float Sensor in the Cleaner Supply Tank

Refer to Figure 5-14.

Tools needed: 3/8" open ended wrench or socket

Parts needed: Replacement Level Float Sensor (Part Number 11-696956-000).

1. Drain the cleaner supply tank. (Refer to draining the cleaner supply tank at the beginning of this section.).
2. Place the machine in transport position with the power supply disconnected.
3. Disconnect cable from level float sensor (push down and away on tab to disconnect).
4. Disconnect tubing from tank, loosen two mounting bolts and remove tank.
5. Remove faulty sensor from the tank using a wiggling and pulling motion.
6. Push new sensor into place and look inside the tank to check position.



NOTE:

Sensor is correctly positioned if the white float hangs down toward the bottom of the tank when machine is in operating position.

7. Replace tank in machine, tighten mounting bolts and replace tubing.
8. Reconnect sensor cable.
9. Fill the cleaner supply tank to verify that there is no leaking from around the new cleaner level float sensor.

Replacing/Cleaning the Cleaner Screen Filter

Parts needed: Cleaner filter - screen only, 200-mesh, part number 11-655044-004 or complete filter assembly with fittings, part number 14-100353-000.

Tools needed: spare container, 3/8" open ended wrench or socket.

Refer to Figure 5-14.

1. Place machine in operating position with covers open.
2. Disconnect power to the machine and the power and ground cables attached to the Cleaner Pump.
3. Slowly disconnect the tubing from the top of the filter. Once air is introduced into the tubing the cleaner will flow back into the tank.
4. Loosen the two bolts at the top of the pump and filter assembly that secure it to the rear frame and lift out the cleaner pump and filter bracket.
5. Disconnect the tubing from the pump outlet fitting (to the cleaner manifold). Move the pump and filter bracket to a workbench.
6. Place a container under the strainer bowl to catch any remaining cleaner and unscrew the bowl on the mesh strainer.
7. Clean the filter/strainer by running under water or replace, if necessary. (filter only p/n 11-655044-004)
8. Replace strainer and bowl, take care to ensure the strainer is on straight, not crushed, and the bowl gasket is properly positioned around the entire groove of the filter body.
9. Reconnect the supply tubing as you replace the pump and filter bracket in the machine, tighten the bolts.
10. Reconnect the pump power and ground cables, and restore power to the machine.
11. Place machine on the lane and turn on the cleaner pump via the “Cleaner Diagnostics” screen in the “Maintenance” menu of the GUI.
12. Test clean one or more lanes (as needed) to verify that all air has been purged from the cleaning system.



NOTE:

To test the cleaning performance set the pattern to a “Clean” mode in the “Design”, “Pattern Parameters” in the “Pattern” menu.

Adjusting the Cleaner Min/Max Pressures

Refer to Figure 5-14.

Tools needed: none.

Adjustment: Min = 20-25 psi, Max = 25-30 psi.

1. Place the machine in the operator position and supply power.
2. Place the machine on the lane and open the two top covers.

3. Navigate to “Cleaning”, “Diagnostics” in the “Maintenance” menu.
4. Select and “OK” both the **Cleaner valve** and **Cleaner pump** to observe the “Min” pressure setting.
5. Turn the white pinch valve located on the return line to the cleaner supply tank clockwise to increase the pressure.
6. Turn the white pinch valve located on the return line to the cleaner supply tank counter-clockwise to decrease the pressure.
7. Select the **Cleaner Pump** and press “OK” to observe the “Max” pressure setting.

Replacing the Vacuum Seal

Tools needed: single-edge razor blade.

Parts needed: New Vacuum Seal (Part Number 14-100487-000 included with spare parts package).

Isopropyl Alcohol (Part number 61-869255-000)

Refer to Figure 5-15.

- (1) VACUUM SEAL
- (2) VACUUM HOUSING

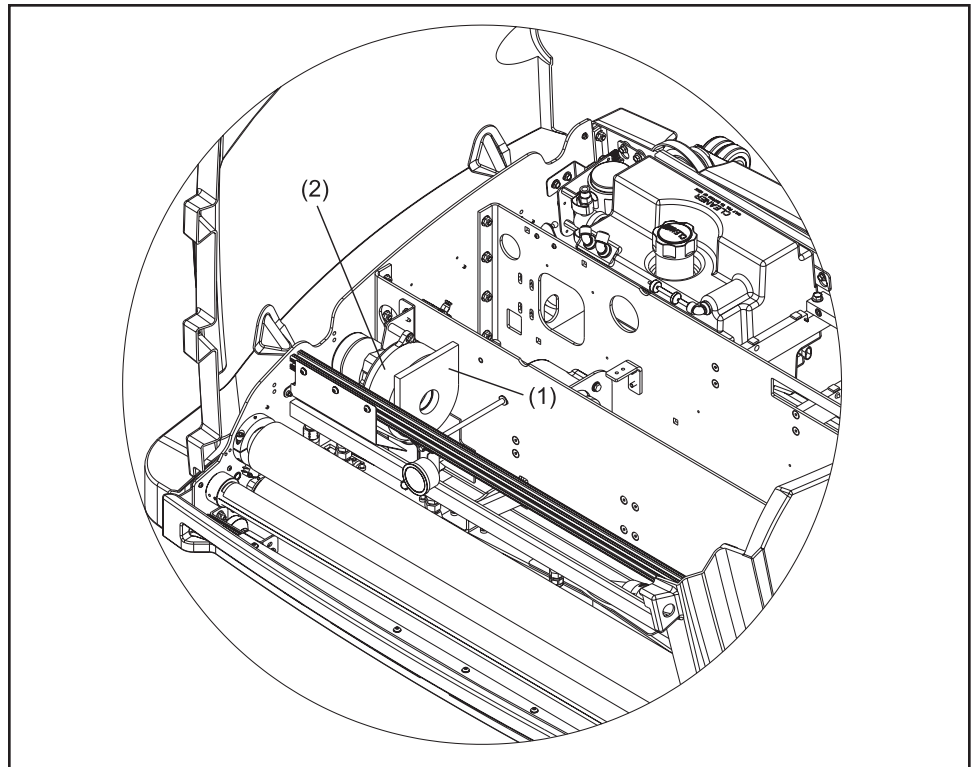

Figure 5-15. Replacing the Vacuum Seal

1. Place the machine in transport position with the power disconnected and the cover off.
2. Remove waste recovery tank

3. Remove the old seal and carefully clean residue with isopropyl alcohol from vacuum housing.
4. Remove self-adhesive backing from new seal
5. Attach new seal to vacuum motor housing, centering the seal over the hole in housing and aligning the flat edge of the seal with the top of the machine.
6. Inspect the 14-100378-000 Absorbent Foam Vacuum exhaust /deflector felt and 14-100104-000, 14-100105-000 and 14-100106-000 vacuum exhaust/deflector felt and replace as needed with 14-860222-000 adhesive.
7. Replace waste recovery tank.



NOTE:

Make sure that the vacuum motor assembly mounting bracket is positioned in the slots to provide even pressure between the vacuum housing and the waste recovery tank.

The Conditioning System

Depressurizing the Conditioning System

Tools needed: None.

1. Enter the “Conditioning” sub menu in “Diagnostics”.
2. Navigate, using the left/right arrows, to the Vent valve and press “OK”.
3. Immediately navigate to the Pressure relief valve and press “OK”.



NOTE:

Each valve function will run for 20 seconds. It may be necessary to repeat steps “2” and “3” for a second time to fully depressurize the system so the pressure sensor reads 0.

Draining the Conditioner Supply Tank

Tools needed: None.

Refer to Figure 5-16.

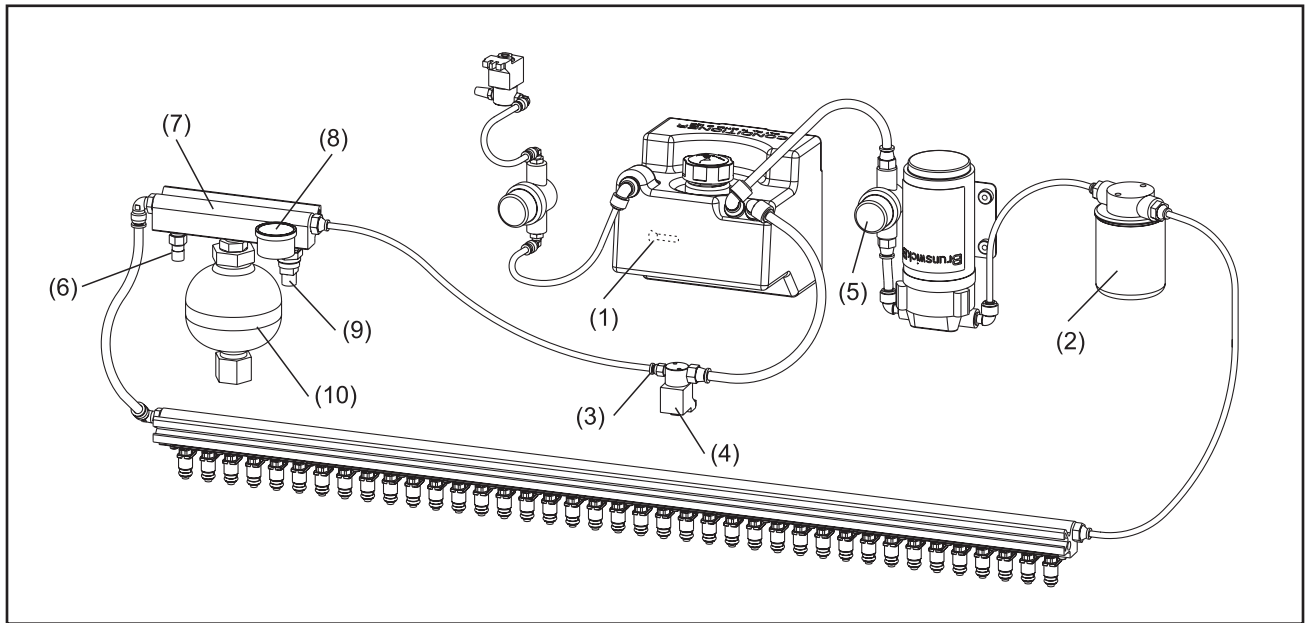

Figure 5-16. Replacing Level Sensor in Supply Tank

- | | | |
|--|--------------------------------|------------------------------------|
| (1) CONDITIONER LEVEL FLOAT SENSOR | (2) CONDITIONER SPIN-ON FILTER | (3) DISCONNECT TO USE DRAIN TUBE |
| (4) CONDITIONER PRESSURE CONTROL VALVE | (5) CONDITIONER SCREEN FILTER | (6) CONDITIONER TEMPERATURE SENSOR |
| (7) ACCUMULATOR RAIL | (8) CONDITIONER PRESSURE GAUGE | (9) CONDITIONER PRESSURE SENSOR |
| (10) ACCUMULATOR | | |

Parts needed: Drain tubing found in the spare parts kit, spare container.

1. Place the machine in the operator position and supply power.
2. Verify that there is no pressure within the conditioning system by viewing the sensor reading in the “Sensor” sub menu in the Maintenance diagnostics menu.
3. If the conditioning system is pressurized, refer to *Depressurizing the conditioning system* at the beginning of the *Conditioning System* section.
4. Locate the conditioner pressure control valve, across from the conditioner supply tank, and place a rag underneath the valve fitting facing the 10-pin side.
5. Remove the tubing, from the conditioner pressure control valve only, that extends to the accumulator rail assembly and attach the drain tubing supplied in the spare parts kit to the end of the tubing you just removed.
6. Route the drain tubing to a container.
7. Go to Conditioning Diagnostics and turn on the vent valve and oil pump.

8. Continue to run pump until the conditioner supply tank has been completely drained.
9. Remove the drain tubing and reconnect the tubing to the conditioner pressure control valve.



NOTE:

It is very important to make sure the tubing is not damaged and that it is inserted completely into the fitting.

Replacing the Level Float Sensor in Conditioner Supply Tank

Tools Needed: 3/8" open ended wrench or socket

Parts needed: Replacement Level Float Sensor, part number 11-696956-000.

Refer to Figure 5-16.

1. Drain the conditioner supply tank. (Refer to draining the conditioner supply tank.)
2. Disconnect power to machine. Disconnect all tubing at conditioner tank.
3. Disconnect cable from level float sensor (push down and away on tab to disconnect).
4. Remove tank by loosening (2) support bolts and lifting tank.
5. Remove faulty sensor from the tank using a wiggling and pulling motion.
6. Push new level float sensor into place and look inside tank to check position.



NOTE:

Sensor is correctly positioned if the white float hangs down toward the bottom of the tank when machine is in operating position.

7. Replace tank into machine and tighten mounting bolts.
8. Reconnect sensor cable.
9. Reconnect tubing at tank.
10. Fill the conditioner supply tank to verify that there is no leaking from around the new level sensor.

Replacing the Conditioner Spin-On Filter

Tools Needed: Shop Towels, 3/4” Open End Wrench or 3/8” Drive 3/4” Socket and Ratchet, Standard Strap Filter Wrench – OEM Brand #25079 or equivalent (available at local automotive parts supplier).

Parts Needed: Replacement Spin-On Oil Filter, part #11-655029-001.



NOTE:

This procedure must be performed in the operating position with the covers open, push the machine out 24” past the foul line out onto the lane surface.



WARNING!

Before the filter is replaced the conditioner system must be depressurized, and the Temperature Cycle must be turned OFF. Failure to do so may result in personal injury to the user, and could also cause damage to the lane machine.

Step 1. Depressurizing the Conditioning System

1. Enter the “Conditioning” sub menu in “Diagnostics.”
2. Navigate, using the Left / Right arrows, to the “Oil Tank Vent “valve and press “OK.”
3. Immediately navigate to the “Oil Pressure Valve” and press “OK.”

Step 2. Removing the Spin On Oil Filter

1. Remove power to the Authority22 by turning off the red toggle switch on the side of the electrical enclosure and unplug the power cord from the lane machine.
2. Place several shop towels under the Spin-On Oil Filter and with the filter housing mounted in the machine, remove by turning the filter counter clockwise as viewed from the top of the machine. If the filter can not be removed by hand, use a Strap Filter Wrench to remove. Drain and discard the filter. Refer to Figure 5-17.

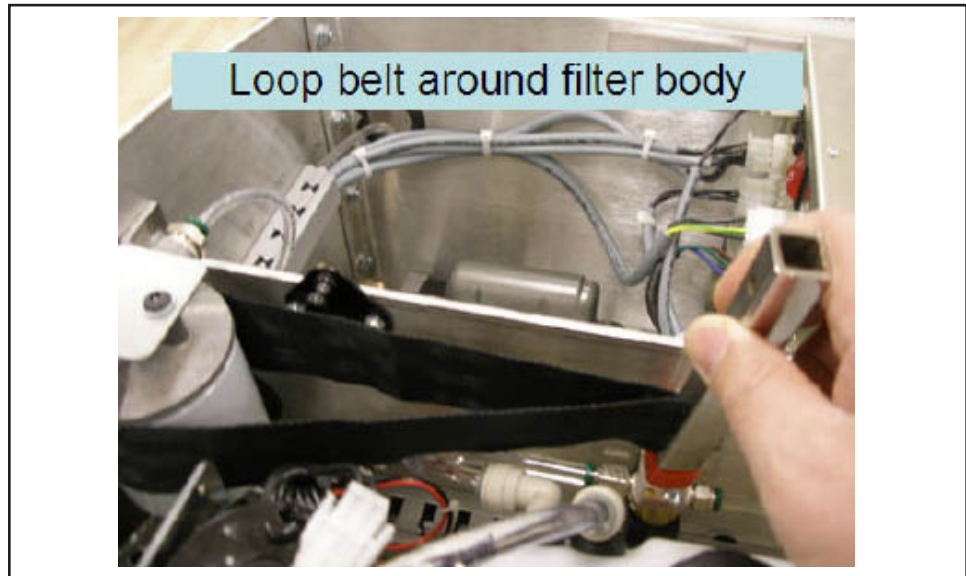

Figure 5-17

Step 3. Installing the New Spin-On Oil Filter

Fill the replacement filter up halfway with lane conditioner and use your finger to lubricate the rubber seal at the top of the filter. With the filter housing mounted in the machine, install by turning the Spin-On Oil Filter in a clockwise direction. Spin until filter stops against the filter housing.

Using a permanent marker, draw a line on the filter and the housing. This will note the position of the filter in relation to the housing, so you have a starting reference point. Refer to Figure 5-18.



Figure 5-18.

Tighten the Spin-On Oil Filter one full turn past the original mark. Use the filter wrench if needed. Refer to Figure 5-19.



Figure 5-19

This should seal the filter to the housing at the correct point to prevent the filter from leaking during normal operation of the Authority22.

Step 4. Bleeding the Conditioner System and Checking for Leaks

Restore power to the Authority22.

Navigate to “Conditioner” “Diagnostics” in the “Maintenance” screen of the Graphical User Interface.

Turn on the “Conditioner Vent Valve.”

Turn on the “Oil Pressure Valve.”

Turn on the “Conditioner Pump.”

Run the conditioner pump in diagnostics until all the air is out of the system. This can be seen as bubbles moving through the conditioner hoses. If air is left in the conditioner system, conditioner pressure variances will occur. Before running the conditioner pump, make sure you have opened the Conditioner Vent Valve and the Conditioner Pressure Valve in the diagnostics screen before you run the Conditioner Pump.

Inspect the filter for leaking. If there are leaks present between the filter and the housing rotate the spin on filter one additional quarter turn clockwise using the Strap Filter Wrench.

Replacing/Cleaning the Conditioner Screen Filters

Refer to Figure 5-16.

Tools needed: Spare container, 3/8" open ended wrench or socket.

Parts needed: Conditioner filter - screen only, 40-mesh, part number 11-655024-004, or complete filter assembly with fittings, part number 14-100321-000.

To replace the conditioner screen:

1. Place machine in operating position with cover open.
2. Disconnect the cables attached to the Conditioner Pump.
3. Slowly disconnect tubing from inlet of filter (once air is introduced into the line, the oil in the tubing will flow into the tank).



NOTE:

Place a container beneath the conditioner bowl and strainer assemble to capture any oil.

4. Loosen the two bolts at the top of the pump and filter assembly that secure it to the rear frame and lift out the cleaner pump and filter bracket
5. Unscrew bowl on the 40-mesh strainer.
6. Clean only the filter by rinsing with isopropyl alcohol or replace, if necessary. (Screen only part number 11-655024-004).
7. Replace screen and bowl.
8. Replace the pump and filter bracket in the machine, tighten the bolts, reconnect the supply tubing and the pump power cable.
9. Restore power to machine.
10. Go to "Conditioner Diagnostics" in the "Maintenance" menu of the GUI. Turn on the conditioner vent valve, the pressure control valve, and the conditioner pump. Verify the bowl strainer does not leak.



NOTE:

This forces air out and circulates oil through the system. Repeat this procedure as needed until there is no air in the conditioning system.

Replacing the Conditioner Pressure Sensor or Temperature Sensor

Refer to Figure 5-16

Tools needed: 1/2" wrench, Adjustable wrench, Spare towels/rags.

Parts needed: Replacement Pressure Sensor, part number 11-696945-000, or Temperature Sensor, part number 11-696944-000.

1. Place machine in operators position and supply power to the machine.
2. Depressurize conditioning system: in the “Conditioner Diagnostics” screen of the “Maintenance” menu, turn on the conditioner vent valve and the pressure control valve until the pressure gauge and digital sensor both read “0”.
3. Disconnect power cord from the lane machine.
4. Disconnect electrical cables from both the pressure and temperature sensors (push down and away on tab to disconnect).



WARNING!

Verify there is no pressure with the analog gauge on the accumulator rail.

5. Loosen and remove 2 nuts (5/16-18), with a 1/2” open end wrench or socket, that secure accumulator rail assembly to the machine’s center compartment wall.
6. Disconnect 3/8" tubing and 1/4” tubing from each end of the accumulator rail assembly.



NOTE:

Place towels underneath tubing and position tubing upward to prevent dripping.

7. Carefully remove accumulator rail assembly and place it on a work bench.



NOTE:

Cover the ends of the tubes to prevent inadvertent drips and drain residual conditioner in a container.

8. Remove the faulty sensor using an adjustable wrench.



NOTE:

Pressure sensor is always on the same side of the rail assembly as the pressure gauge, with the temperature sensor on the other side.

9. Inspect the sensor mounting hole and remove any debris in threads.
10. Install new sensor with the adjustable wrench, there should be pre-applied pipe sealant on the threads.
11. Replace accumulator rail assembly.
12. Place the accumulator rail assembly in position and insert and tighten nuts that secure the assembly to the machine's center compartment wall.
13. Reconnect 3/8" and 1/4" tubing.
14. Reconnect cables from both sensors at connector.
15. Turn on "Settings, Temperature Cycle" in the "System" menu to cycle conditioner through the system.

The Buffing System

Adjusting the Buffer Brush

Tools needed: 1/8" Allen wrench, 3/8" open-end wrench, 9/64" Allen wrench, buffer/squeegee adjustment tool.

1. With the machine in the operators position, lower the buffer brush in the diagnostics for conditioning using the "Toggle buffer brush" button.
2. Once the brush is in the down position, disconnect power cord from the machine and lift into the transport position.
3. Lay the handle on the floor with a towel underneath and open the 7-pin side top cover.
4. Using the 1/8" allen wrench, remove the eight button head screws that mount the 7-pin side cover to the frame. Remove the side cover.
5. Loosen the four (4) bolts that mount the brush lifting motor assembly, to the 7-pin side of the machine, using a 3/8" open end wrench. Refer to Figure 5-20.

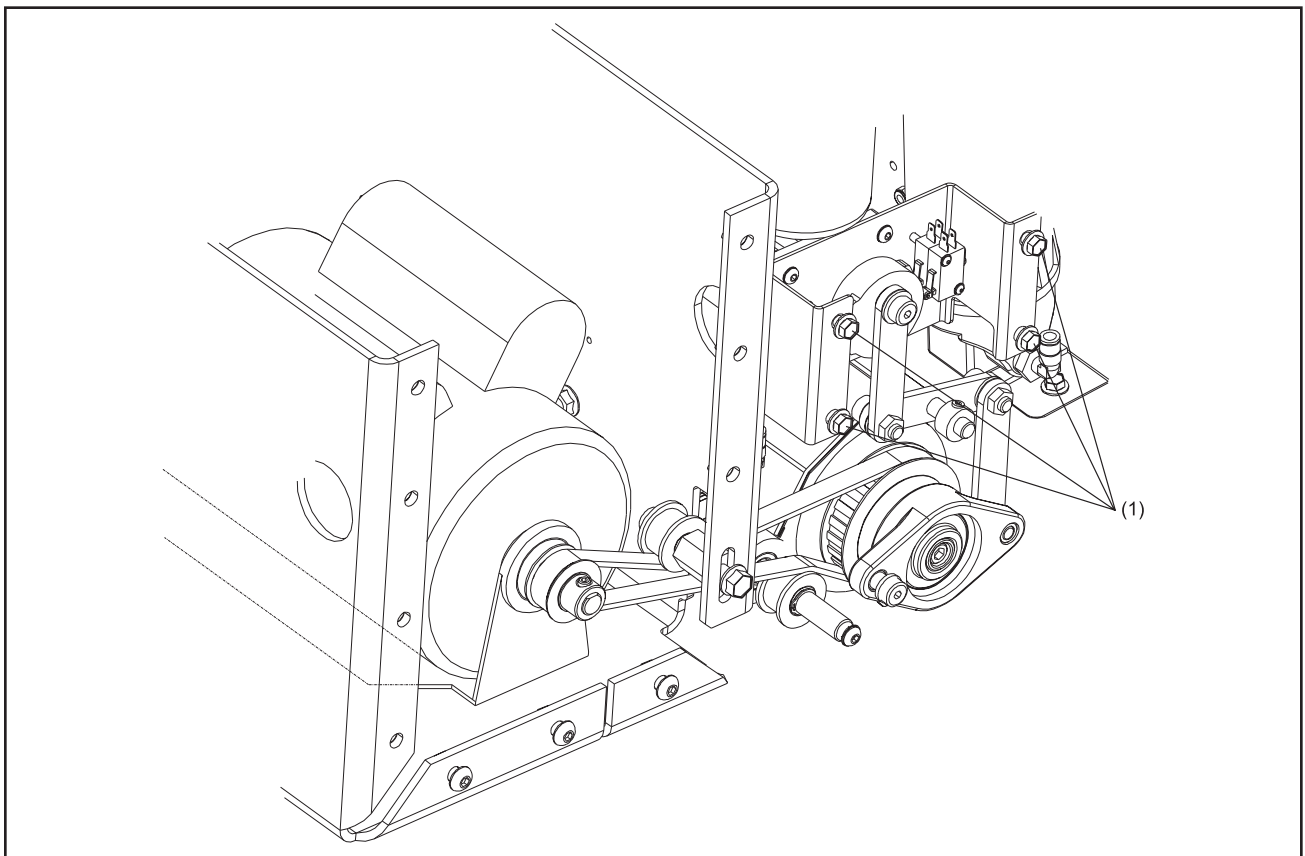

Figure 5-20. Adjusting the Buffer Brush

(1) FOUR MOUNTING BOLTS

- Place adjustment tool (mounted inside the lane machine in front of the electronics enclosure) across the rear wheel and drive wheel on the 7-pin side of the machine. Refer to Figure 5-21.

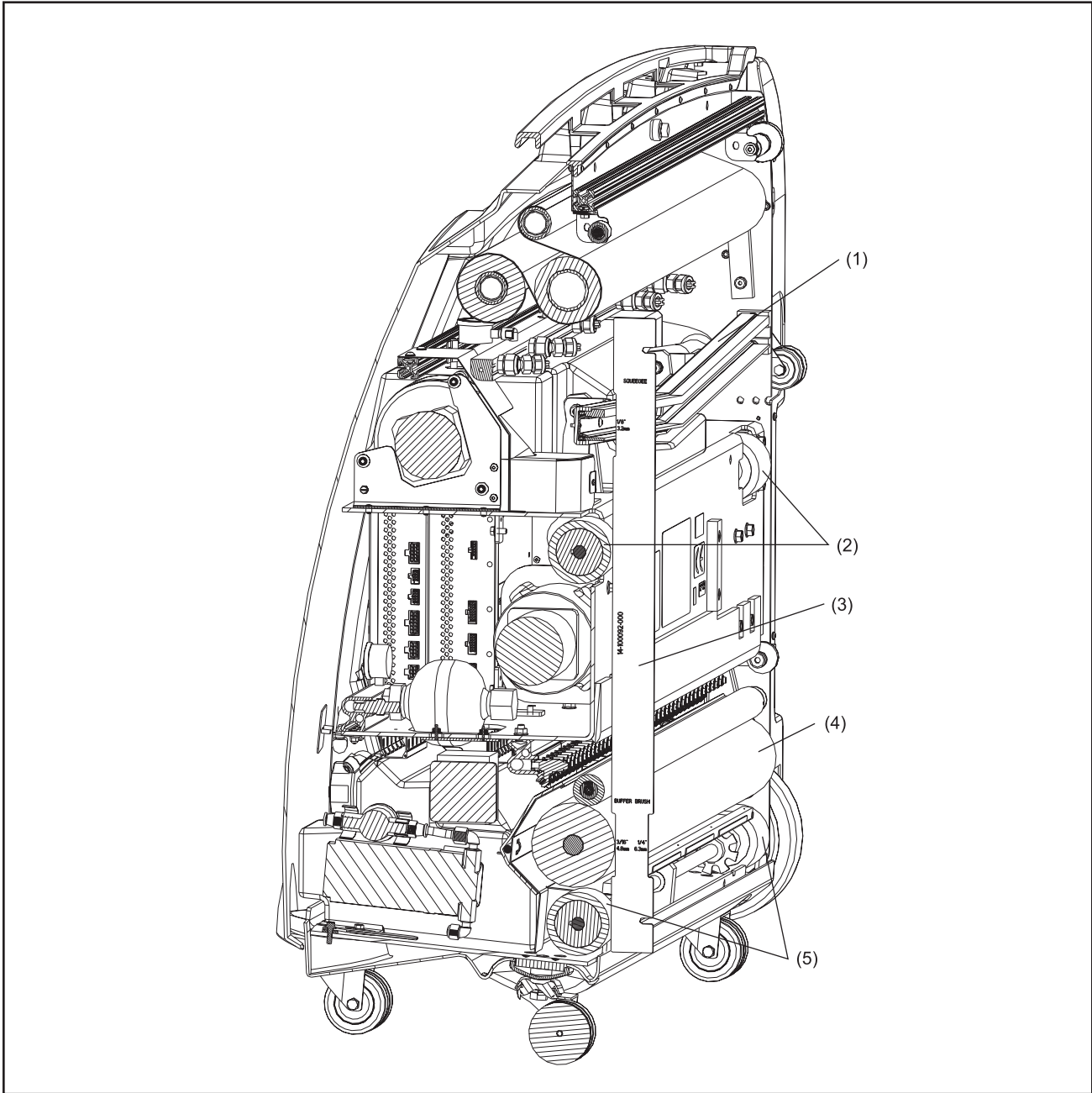

Figure 5-21. Adjustment Tool - Section View

- | | | |
|-----------------------------------|---------------------------|-------------------------------------|
| (1) SQUEEGEE/VACUUM HEAD ASSEMBLY | (2) TRACTION DRIVE WHEELS | (3) BUFFER/SQUEEGEE ADJUSTMENT TOOL |
| (4) BUFFER BRUSH | (5) REAR SHAFT WHEELS | |

7. Verify that the desired adjustment notch is sitting over the buffer brush (it is suggested to start with the 1/8" or 3/16" notch).
8. To raise the buffer brush, lower the motor position in the slots of the 7-pin side wall.
9. To lower the buffer brush, raise the motor position in the slots of the 7-pin side wall.
10. When the brush is in desired position, snug two of the four mounting bolts using the 3/8" wrench.
11. Verify adjustment on 7-pin side of machine, then check the adjustment across the rear and drive wheels on the 10-pin side of the machine.
12. If the adjustment is equal on both sides of the machine, then completely tighten the four mounting bolts making sure not to over tighten and deform the adjustment slots. If the adjustment is not balanced, continue with the following steps.
13. Locate the collar, on the 10-pin side, inside of the machine in the conditioning compartment (found directly under the dispersion roller motor) that holds the two sides of the brush lifting shaft. Refer to Figure 5-22.

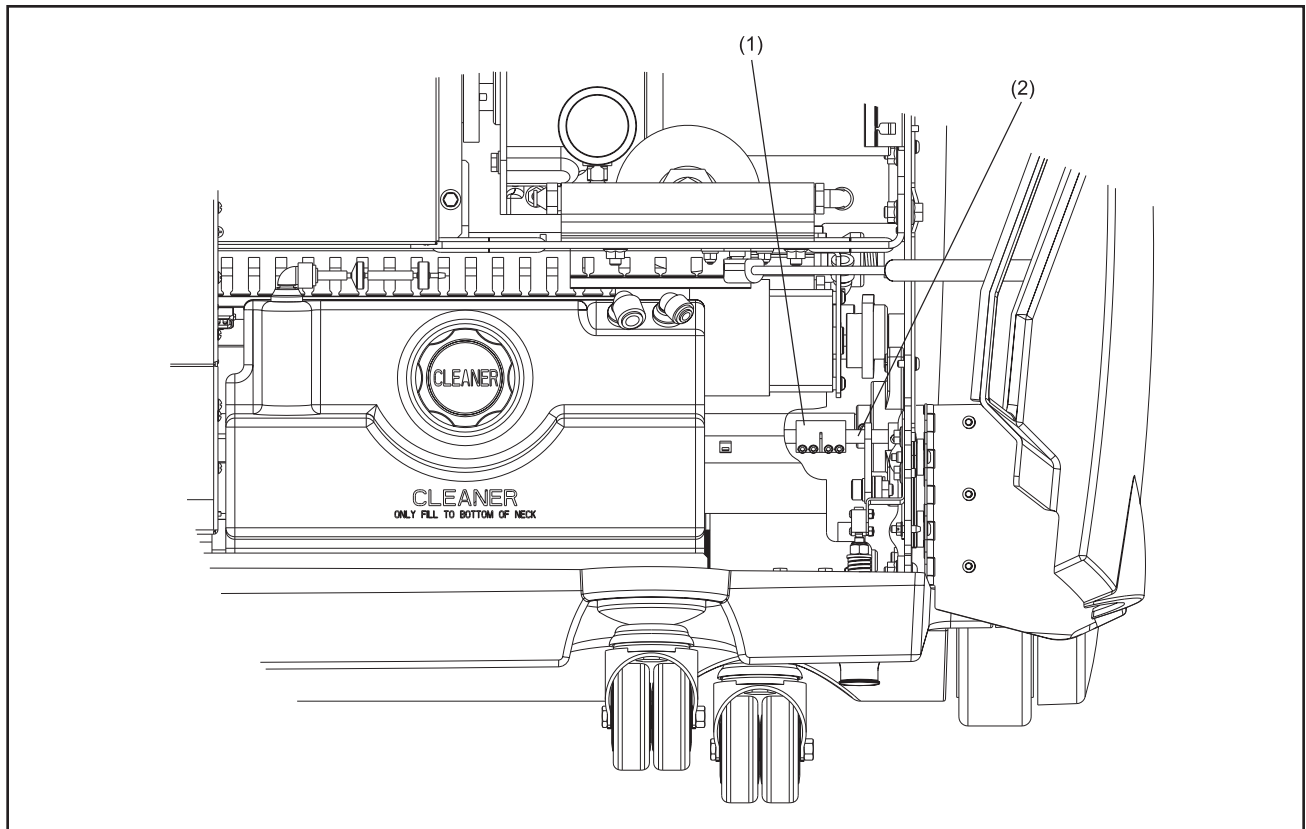

Figure 5-22. Collar

(1) COLLAR

(2) SHORT SHAFT

14. Slightly loosen the 2 screws, using a 9/64" allen wrench, on the short side of the shaft assembly.
15. Check the adjustment of the buffer brush and push/pull on the buffer brush wall-mounted bearing until the proper adjustment is achieved.
16. Tighten the screws on the collar.
17. Tighten (but do not over tighten) the four mounting bolts making sure not to deform the adjustment slots. Refer to Figure 5-16.
18. Replace the 7-pin side cover and fasten to the machine.

Replacing the Buffer Brush

Tools needed: 1/8" Allen wrench, and long 1/4" T-Wrench (supplied with kit).

Parts needed: Buffer Brush Assembly, part number 14-100043-000, and attachment screw, part number 11-005308-000, blue loctite.

Refer to Figure 5-23.

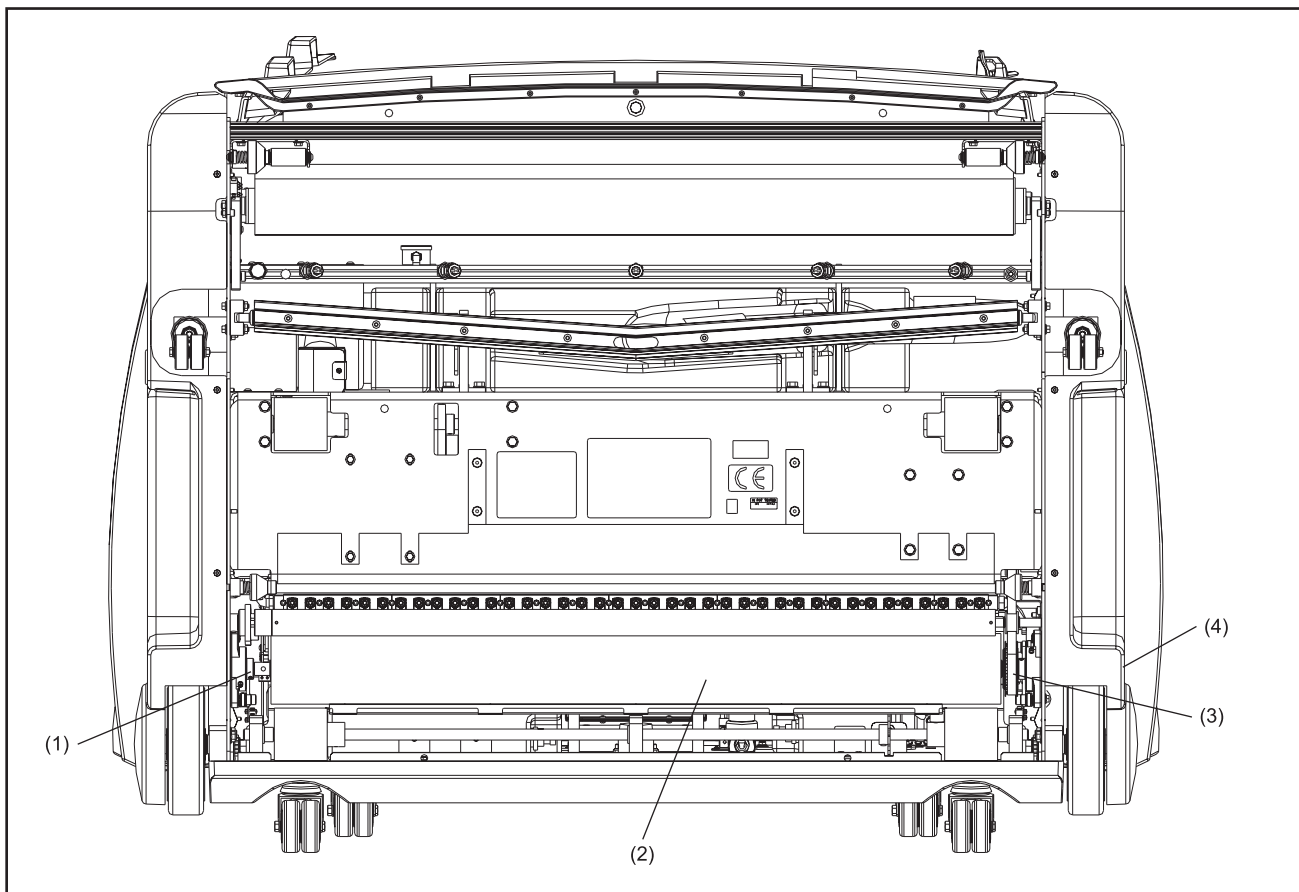

Figure 5-23. Replacing the Buffer Brush

- | | | |
|--|------------------|-------------------------|
| (1) WALL MOUNTED BEARING | (2) BUFFER BRUSH | (3) BUFFER DRIVE PULLEY |
| (4) ACCESS HOLE FOR 1/4" SOCKET HEAD CAP SCREW | | |

1. Place machine in transport position.
2. Remove 2 set screws on the 10-pin side, wall-mounted buffer brush bearing using a 1/8" Allen wrench.
3. Remove socket-head cap screw inside the buffer drive pulley using 1/4" T-wrench. This will allow the buffer brush shaft to separate from the buffer drive pulley, which will remain in the machine.



NOTE:

Access the socket-head cap screw via the access hole on the 7-pin side of the machine's cover, above the 8" lane wheel.

4. Slide buffer brush toward 10-pin side of machine, swing brush away from the machine and then slide brush out of the bearing housing.
5. Inspect the groove-end of the buffer shaft and make sure there are no burrs or scars that may effect how well the brush slides into the wall-mounted bearing. File if necessary.
6. Install new buffer brush by reversing step 4.
7. Replace socket-head cap screw using blue loctite.
8. Replace set screws on wall-mounted bearing.



NOTE:

Make sure that the set screws align within the groove on the end of the buffer brush shaft.

9. Tighten set screws.
10. Verify the adjustment of the buffer brush using the straightedge alignment tool.
11. Place the buffer/squeegee adjustment tool from the drive wheel to the rear wheel, with the edge of straightedge resting on both wheels.
12. Check to ensure that the brush contacts the desired notch of the adjustment tool.
13. Check adjustment on both the 7-pin and the 10-pin sides of the machine.
14. Adjust if necessary.

For information see **Adjusting the Buffer Brush**.

Adjusting the Buffer Belt Tension

Tools needed: adjustable wrench, 1/2" wrench.

Parts needed (if replacing): Buffer Drive Belt, part number 11-655022-000.

Refer to Figure 5-24.

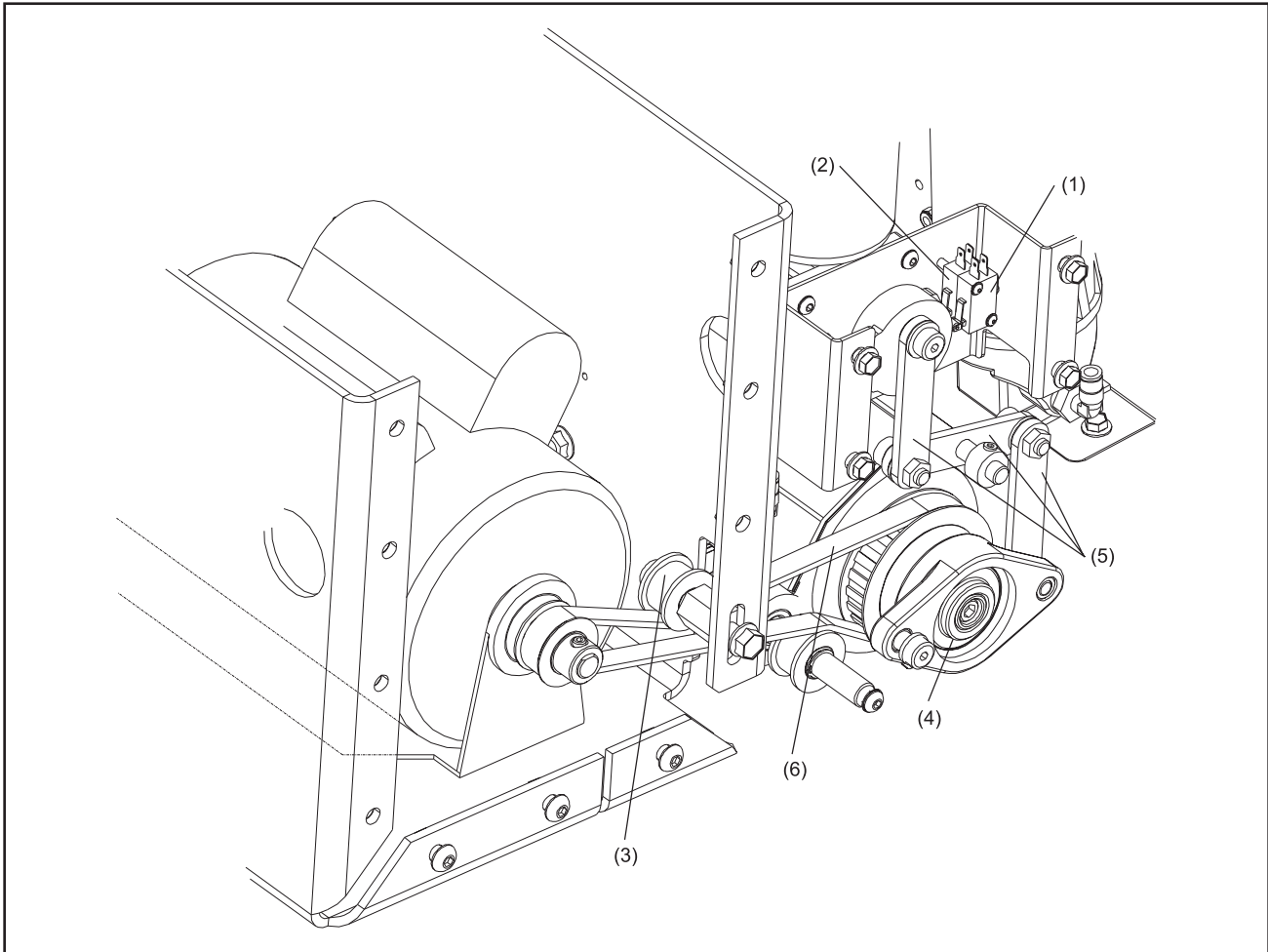

Figure 5-24. Adjusting Buffer Belt Tension, Replacing Buffer Up/Down Switches, Lubrication Buffer Brush Bearings and Lubricating Brush Lifting Assembly

- | | | |
|--------------------------|-----------------------------------|--------------------------------|
| (1) BUFFER UP SWITCH | (2) BUFFER DOWN SWITCH | (3) BUFFER BELT IDLER ASSEMBLY |
| (4) BUFFER BRUSH BEARING | (5) BUFFER BRUSH LIFTING LINKAGES | (6) BUFFER DRIVE BELT |

1. Place machine in transport position with the power supply disconnected.
2. Remove the side cover from the 7-pin side of the machine.
3. Place machine in operating position.
4. Supply power to machine.
5. Lower buffer brush by selecting “toggle buffer up/down” on the “Conditioner diagnostics” screen in the “Maintenance” menu.

6. Disconnect power from machine.
7. Place adjustable wrench on the hex-mount inside the machine and place the 1/2" wrench on the bolt on the outside of the machine.
8. Loosen the bolt from the outside using the 1/2" wrench.
9. To **increase** belt tension, lower the idler assembly.
10. To **decrease** belt tension, raise the idler assembly.
11. Secure the assembly position by tightening the nut (place adjustable wrench on spacer nut inside machine, and tighten bolt on the outside of machine using 1/2" wrench).



NOTE:

Make sure that the belt tension is not too tight or too loose. Poor adjustment can cause damage to belt and/or motor.

Replacing the Buffer Up/Down Switches

Refer to Figure 5-24.

Tools needed: 1/16" Allen wrench, 3/8" open-end wrench, 1/8" Allen wrench.

Parts needed: replacement switches (Part Number 11-616026-000).

1. Place the machine in operating position with the cover open and the power supply connected to the machine.
2. Turn on the "Buffer lift" motor, in the "Conditioning", "Diagnostics" of the "Maintenance" menu and turn off when set screw on the cam is facing upward.
3. Disconnect power cord from the machine.
4. Disconnect motor cable from quick-connect cable harness leaving the wire assembly attached to the switches.
5. Disconnect buffer switch cables from quick-connect cable harness.
6. Remove the 4 bolts that secure the brush lifting bracket assembly to the machine side wall using a 3/8" open-end wrench.
7. Loosen set screw in the cam attached to the up/down motor shaft using a 1/8" Allen wrench.
8. Carefully remove the up/down motor assembly from the machine (motor, bracket, and switches).
9. Identify faulty switch.



NOTE:

The up/down switches (which are mounted back to back on the bracket) can be distinguished by the color of their wires; the “up” switch has green and white cables, the “down” switch has blue and black cables.

10. Disconnect cables from faulty switch at cable connectors.
11. Remove switches from the mounting bracket by loosening and removing 2 mounting screws using a 1/16" Allen wrench.
12. Remove faulty switch.
13. Connect cables to new switch at fast-on cable connectors.
14. Position switches on mounting bracket as close to the motor shaft as possible and tighten screws that secure switches to the bracket.
15. Replace the up/down motor assembly (motor, bracket, and switches) aligning set screw in the cam with the flat on the motor shaft and tighten into position. Ensure that the lobes of the cam line up with the switches.
16. Insert the four bolts that secure the assembly to the 7-pin side of the machine wall using a 3/8" open-end wrench.
17. Reconnect motor cable at quick- connect cable harness.
18. Check the buffer brush adjustment (Refer to “Adjusting the buffer brush”)

Lubricating the Buffer Brush Bearings

Refer to Figure 5-24.

1. Attach grease gun to the grease fitting located on the wall mounted buffer bearing.
2. Squeeze gun twice.
3. Repeat for the opposite side.

Lubricating the Buffer Brush Lifting Assembly

Refer to Figure 5-24.

1. Apply one drop of oil to the bearings in the buffer brush lifting linkages on 7 and 10-pin sides.

Replacing the Dispersion Roller

Tools needed: 5/32" Allen wrench.

Refer to Figure 5-25.

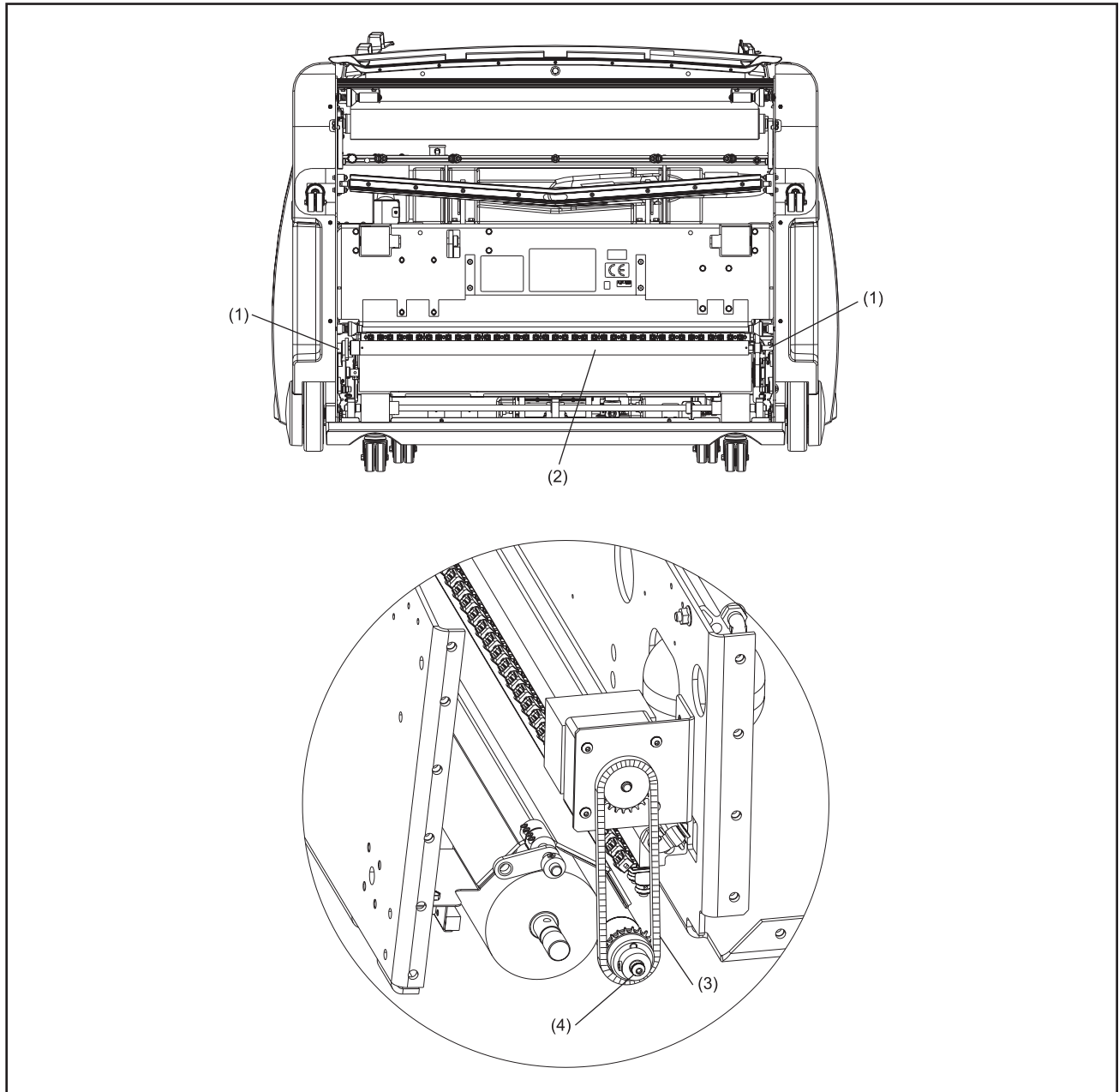

Figure 5-25. Replacing and Lubricating Dispersion Roller

- | | | |
|---|-----------------------|-----------------------------|
| (1) DISPERSION ROLLER MOUNTING BOLTS | (2) DISPERSION ROLLER | (3) DISPERSION ROLLER CHAIN |
| (4) GREASEABLE END OF DISPERSION ROLLER | | |

1. Place machine in transport position with the power supply disconnected.
2. Remove dispersion roller.

- a. Remove side covers from machine.
 - b. Remove 2 button-head bolts—one from each end of dispersion roller using a 5/32" Allen wrench.
 - c. Slide the dispersion roller out, removing the roller drive chain from the 10-pin side of the machine.
3. Position the new dispersion roller in place, sprocket end first, replacing the chain on the sprocket.
 4. Replace the buffer brush idler pulley on the mounting shaft and ensure that it's in-line with the motor drive and brush drive pulleys, and make sure the drive belt is in proper position.
 5. Insert button head bolts and position the dispersion roller in the center of the mounting slots. Refer to Dispersion Roller Adjustment.
 6. Tighten button head bolts completely.
 7. With the machine in the operator position, lower the buffer brush in the diagnostics for conditioning using the "Toggle Buffer Brush" button.
 8. Once the brush is in the down position, disconnect power cord from the machine and lift into the transport position.
 9. Verify that there is slight contact between the buffer brush and dispersion roller across the entire width. Adjust the dispersion roller bolt in the side frame slot if necessary for uniform contact.

Lubricating the Dispersion Roller

Refer to Figure 5-25.

1. Place machine in transport position with power supply disconnected.
2. Remove side cover from 10-pin side of machine.
3. Remove the button head bolt that fastens dispersion roller on the 10-pin side of the machine.
4. Insert grease fitting (part number 14-100202-000, supplied in spare parts package) into the dispersion roller.
5. Attach grease gun with standard bearing grease and pump 2 to 3 times.
6. Remove grease fitting and insert bolt.
7. Check adjustment to buffer brush and tighten.

For more information see **Adjusting the buffer brush**.

The Drive System

Replacing the End-of-Lane Sensor

Refer to Figure 5-26.

Tools needed: adjustable wrench.

Parts needed: replacement EOL sensor (Part Number 14-100235-000).

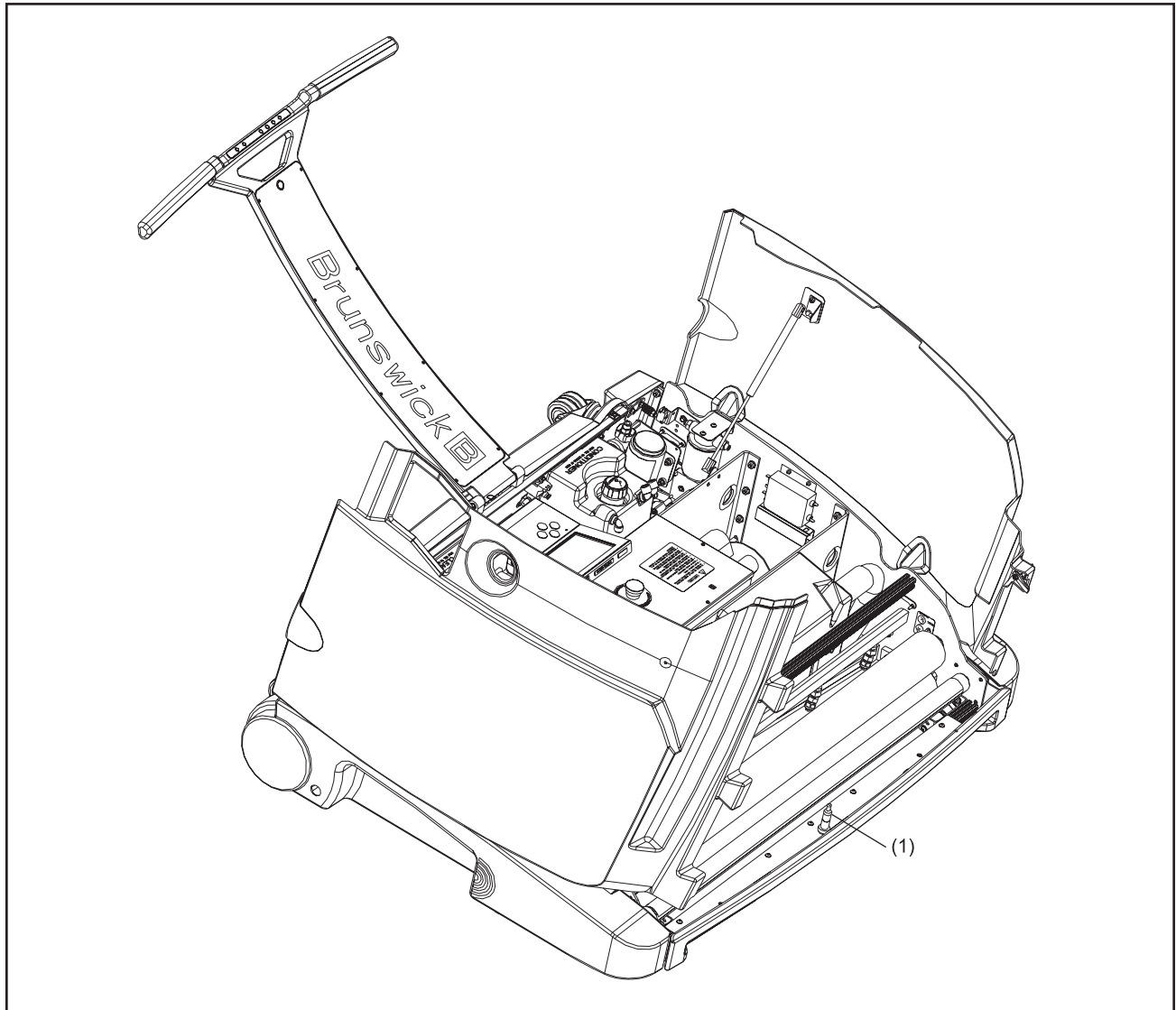

Figure 5-26. End-of-Lane Sensor

(1) END-OF-LANE SENSOR

1. Place machine in transport position with the cover open and power supply disconnected.
2. Loosen and remove nut at base of sensor.

3. Remove black O-ring from base of sensor.
4. Disconnect sensor cable from the quick-connect cable harness.
5. Pull sensor out from the top side of the machine and remove the second O-ring on top side of the sensor.
6. Place an O-ring under the top-side nut and then install new sensor from top side of the machine.
7. Place the second O-ring on the sensor pushing it up to the bottom side of the mounting shield.
8. Insert and tighten nuts at base of sensor until the end of the sensor is just even with the bottom edge of the lower nut.



NOTE:

Do NOT over tighten nuts.

Adjusting the Distance Encoder

Tools needed: 11/16" wrench, 3/8" socket wrench, feeler gauges.

Refer to Figure 5-27.

- (1) DISTANCE ENCODER
- (2) MOUNTING BRACKET
- (3) ENCODER WHEEL SPROCKET

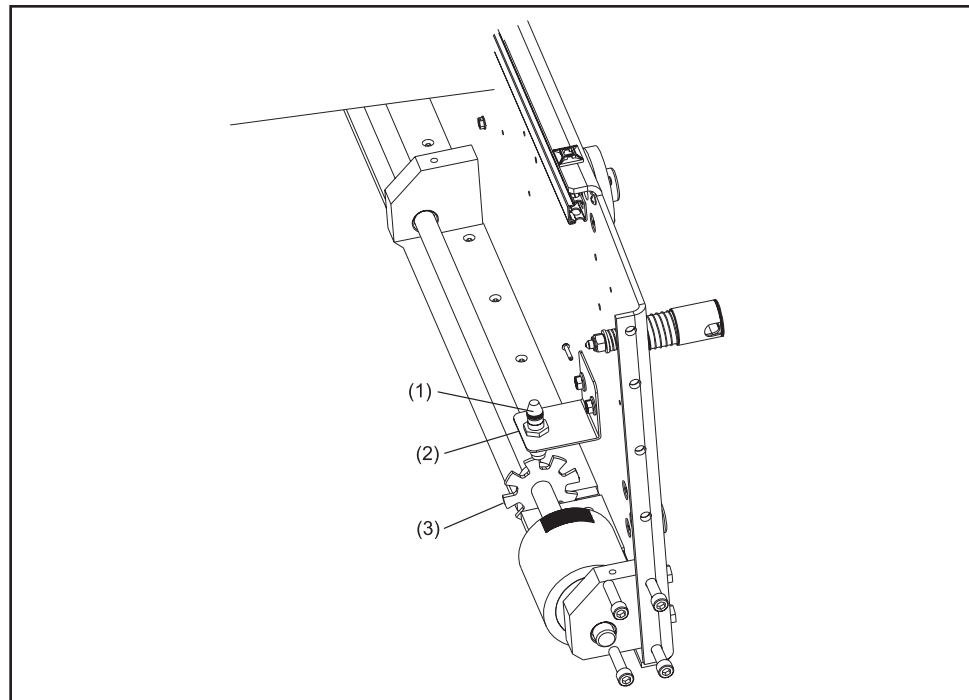

Figure 5-27. Distance Encoder

1. Place machine in transport position with the power supply disconnected.
2. Check the distance between the encoder and the encoder wheel sprocket, using the set of feeler gauges, and verify that it is 1.5mm +/- 0.5mm (.06" +/- .02"). To adjust distance, do the following steps:

- a. Loosen mounting nut on bottom side of mounting bracket using 11/16" wrench.
- b. Adjust assembly position so that the sensor end of the distance encoder extends 15/16" from the bottom side of the encoder bracket
- c. Tighten mounting nut to secure position.
- d. Check the distance between the encoder and the encoder wheel sprocket, using the set of feeler gauges, and verify that it is 1.5mm +/- 0.5mm (.06" +/- .02").

Replacing the Distance Encoder

Refer to Figure 5-27.

Tools needed: 11/16" wrench, 3/8" socket.

Parts needed: replacement distance encoder (Part Number 14-100254-000).

1. Place the machine in transport position with the cover open and power supply disconnected from the machine.
2. Loosen and remove bolts that secure encoder bracket to machine wall (Located underneath the Conditioner supply tank).
3. Disconnect encoder cable from the cable harness.
4. Pull encoder assembly out from the top side of machine.
5. Remove mounting nut on bottom side of mounting bracket using 11/16" wrench.
6. Install new encoder assembly from top side of the machine so that the sensor end extends 15/16" from the bottom side of the encoder bracket.
7. Insert and tighten mounting nut to secure encoder assembly to bracket.
8. Replace bolts to secure encoder bracket to machine wall.
9. Connect encoder cable to the quick-connect cable harness.
10. Check the distance between the encoder and the encoder wheel sprocket. It should be 1.5mm +/- 0.5mm (.06" +/- .02").
11. Adjust encoder as needed.

Adjusting the Traction Drive Chain Tension and Alignment

Tools needed: 3/8" socket wrench, 5/32" allen wrench.

Refer to Figure 5-28.

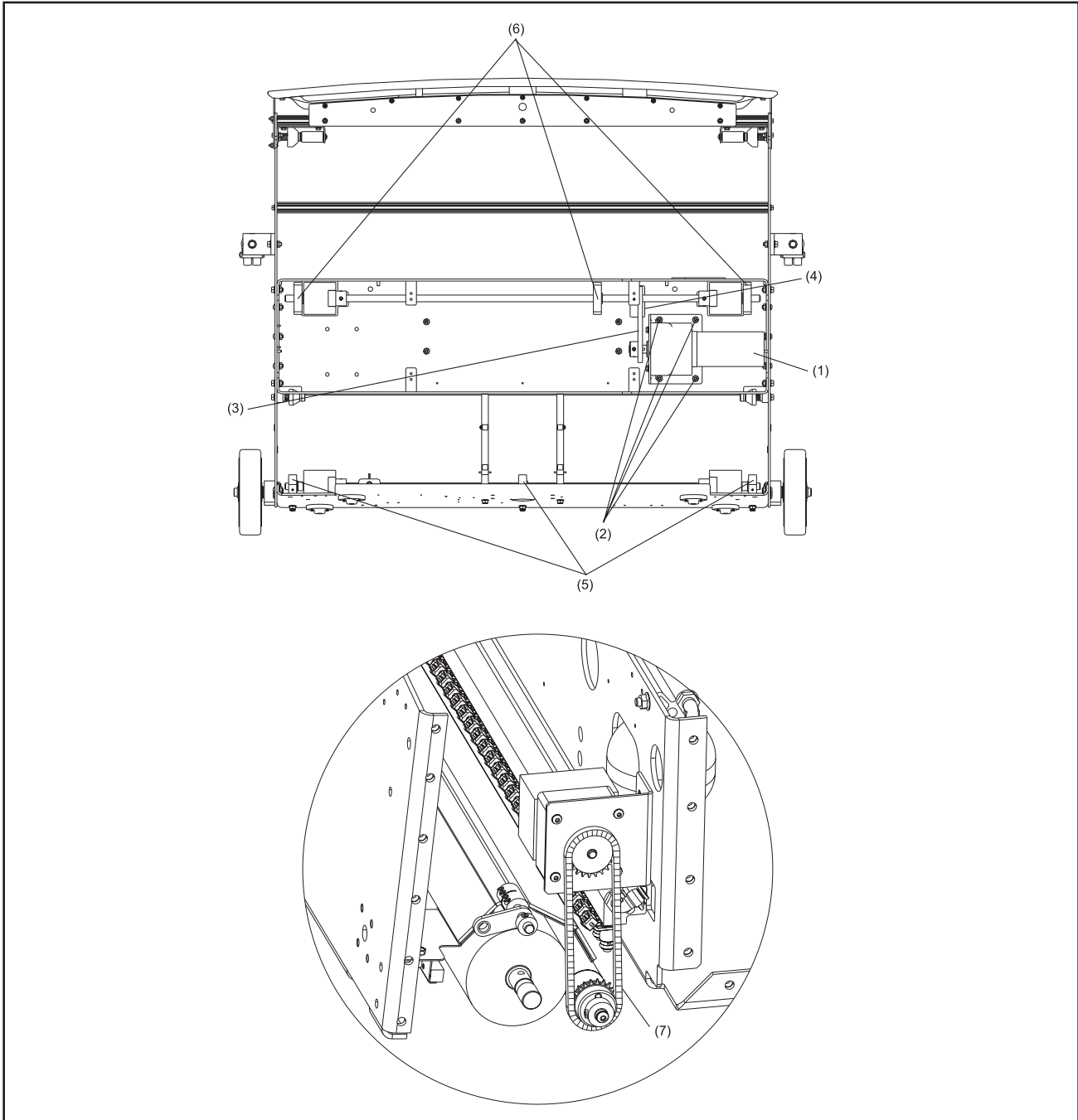

Figure 5-28. Adjusting and Lubricating Drive Chains

- | | | |
|-----------------------------------|---|-----------------------------------|
| (1) TRACTION DRIVE MOTOR | (2) TRACTION DRIVE MOTOR MOUNTING BOLTS | (3) TRACTION DRIVE CHAIN |
| (4) TRACTION DRIVE SHAFT SPROCKET | (5) REAR SHAFT BEARING BLOCKS | (6) TRACTION DRIVE BEARING BLOCKS |
| (7) DISPERSION ROLLER CHAIN | | |

1. When you depress the traction drive chain, there should be about 3/8" of movement in the chain. If there is too much, or too little movement, follow this procedure.
2. Place machine in transport position with power supply disconnected.
3. Slightly loosen 4 mounting bolts that secure the traction drive motor to the frame.
4. Place machine in operating position.
5. Check movement of chain.
6. To tighten chain, slide traction drive motor assembly away from the traction drive wheels to tighten up slack.
7. To loosen chain, slide traction drive motor assembly toward the traction drive wheels to provide more slack.
8. Tighten the 4 bolts on the bottom side of the center compartment to align the chain.
9. Loosen the 2 set screws on the drive shaft sprocket with a 5/32" allen wrench.
10. Carefully, tap the sprocket with a soft-face hammer to align with the motor sprocket.



NOTE:

Improper alignment will cause drive system to make noise during travel.

11. Tighten the set screws with the 5/32" allen wrench.

Lubricating the Traction Drive Chain and Dispersion Roller Chain

Refer to Figure 5-28.

1. Apply a small amount of chain grease to the traction drive chain at the sprocket and spread the grease across the chain links.
2. Repeat the procedure for the dispersion roller chain.

Lubricating the Bearing Blocks

Refer to Figure 5-28.

1. Apply one drop of oil to each side of the rear-wheel bearing blocks where the shaft and bearing meet.
2. Repeat the procedure for the traction drive bearing blocks.

General Machine Maintenance

Replacing Fuses

Tools needed: fuse puller, replacement fuses included in spare parts kit.

1. Place machine in the operator position with the cover open and power supply disconnected.
2. Remove GUI to access enclosure screws.
3. Remove cover from electronics enclosure by removing 6 screws in cover.
4. Locate motor control board (The motor control board is the large board on the top)



NOTE:

See fuse drawings in Appendix.

5. Locate bad fuse (all fuses are labeled on the control board).



NOTE:

See electrical diagrams in the appendix for more information.

6. Remove fuse using fuse puller.
7. Install new fuse.



WARNING!

Always use the correct size and amperage fuse.

8. Replace cover and reinstall cover screws and GUI.

Replacing the Cord-Kill Switches

Tools needed: 3/8" wrench, 1/16" allen wrench, 1/4" open-end wrench.

Parts needed: replacement switch (Part Number 11-616031-000).

Refer to Figure 5-29.

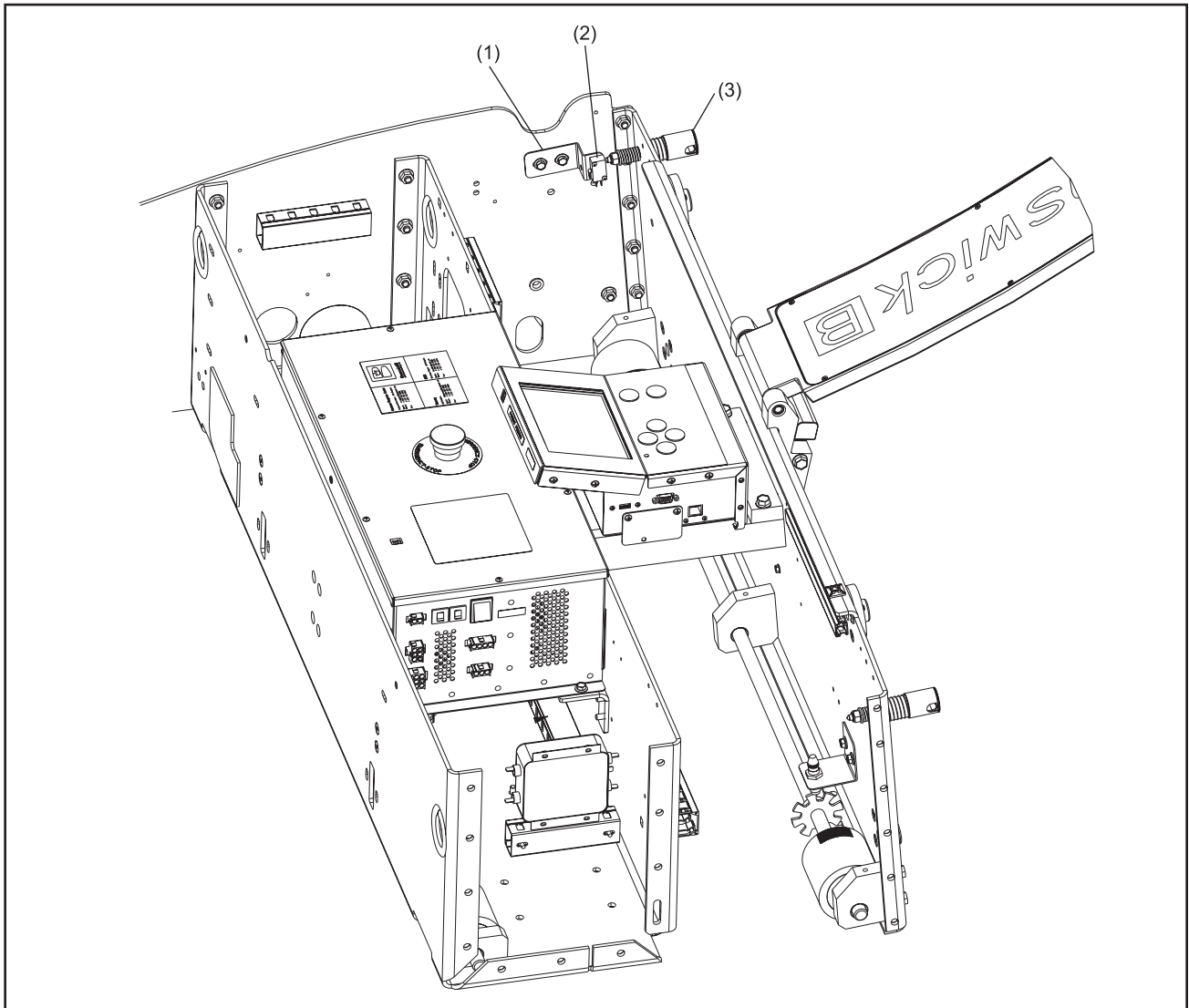

Figure 5-29. Replacing Cord Kill Switches

(1) CORD KILL SWITCH BRACKET

(2) CORD KILL SWITCH

(3) CORD KILL STUD

1. Place machine in operating position with cover open and power supply disconnected.
2. Identify the bad switch using the Diagnostics screen on the GUI (Refer to Troubleshooting section for instructions on using the GUI Diagnostics).

3. Remove the 2 bolts that secure the cord-kill bracket to the machine side wall and remove the cord-kill switch assembly.
4. Remove the screws that secure the switch to the bracket using a 1/16" Allen wrench & 1/4" open-end wrench.
5. Remove faulty switch.
6. Using the old switch as a guide, reconnect the wires on the new switch following the order for wire connections. Refer to electrical schematics in the Appendix for details.
7. Mount the new switch to the bracket using the 2 mounting screws.
8. Insert and tighten the 2 bolts to secure the bracket to the side wall.
9. Check to ensure there is a 1/32" to 1/16" gap between the cord-kill stud and the switch body to provide the proper contact between the plunger on the lanyard and the switch.

Section 6: Troubleshooting

The Authority22's Graphical User Interface (GUI) will alert you to most operational or maintenance problems by displaying an error or warning message. It is also a powerful tool for troubleshooting. This section teaches you to properly use the GUI to effectively troubleshoot, lists all the messages you might encounter and provides guidance for correcting problems.

This section also provides a highly detailed look at the machine's sequence of operations. Understanding the normal operation can be useful for identifying and correcting problems when they arise.

In this section you will find:

1. A sequence of machine operation, system-by-system.
 - a. Preparing for operation
 - b. The cleaning system
 - c. The conditioning system
 - d. The buffing operation
 - e. The traction drive system
2. A guide to troubleshooting using the GUI.
3. A list of error messages with troubleshooting guidance.
4. A list of warning messages with troubleshooting guidance.
5. A list of maintenance messages with replacement information.
6. A list of mechanical failures with troubleshooting guidance



WARNING!

Do not attempt to undertake any maintenance or service for which you are not qualified. If you need assistance, or are interested in training, call Brunswick Customer Response Center, or contact your Brunswick Sales or Service Representative.

If a message appears or a problem occurs that is not addressed in the troubleshooting section, please contact your authorized Distributor or the Brunswick Customer Response Center (CRC) in the United States at 1-800-YES-BOWL, or internationally at 231-725-4966. For non emergency support, e-mail crsupport@brunbowl.com

Sequence of Operation

This section provides a detailed look at how the machine, its controller, and its component parts work together in sequence. Understanding the normal sequence of operations can be a useful resource for troubleshooting.

Preparing for Operation on Approach

1. When the operator supplies power, the machine warms the conditioner to operating temperature. *(This will only occur if the Temperature Cycle feature is turned “ON” on the GUI)* The control system:
 - a. Opens the conditioner pressure control valve and the conditioner vent valve, allowing the conditioner pump to circulate conditioner through the heated injector rail.
 - b. When conditioner reaches operating temperature (factory-set to 80°F (21°C), the conditioner pump turns off and the pressure control valve and the conditioner vent valve close.
 - c. The operator screen displays “READY” when the conditioner has reached operating temperature.



NOTE:

You can press the “OK” button at any time during the temperature cycle to temporarily stop this feature to condition the lanes. Operating within 10°F (12° C) +/- the target temperature will have minimal effect on the pattern.

2. When the operator presses “OK” to prepare the machine to operate, the control system:
 - a. Rotates the duster cloth take-up roll to lower the duster contact roller into operating position and confirms that the duster cloth is in the “down” position via the duster down switch.
 - b. Lowers the squeegee head assembly into operating position via the squeegee up/down motor and confirms that the squeegee is in the “down” position via the squeegee down switch.
 - c. Turns on the conditioner pump and conditioner vent valve to slightly over-pressurize the conditioning system (accumulator and injector rail assembly) and then turns off the conditioner pump and vent valve.
 - d. Opens the conditioner pressure control valve and conditioner vent valve to allow conditioner to flow back to the conditioner tank until the system has reached target pressure.
 - e. Starts the vacuum motor.
 - f. The operator screen displays “PUT THE MACHINE ON THE LANE” when the machine is ready to begin operation.

Normal Clean and Condition Operation on Lane

1. As the Authority22 is placed on the lane, the system sprays a pulse of cleaner as the duster contact roller assembly is lifted off the “down” switch (only if the start cleaner distance and the start squeegee distance are set at “0” in the Pattern Parameters Screen).
2. Once the machine is properly seated on the lane with the larger rear wheels aligned with the gutters just in front of the foul line, and the operator presses “OK” for the second time, the control system:
 - a. Turns on the traction drive motor to accelerate the machine toward the pin deck.
 - b. Directs the cleaner pump to apply a steady spray of cleaning fluid on the lane.
 - c. Vacuums the used conditioner and cleaner.
 - d. Lowers the buffer brush into contact with the lane surface via the buffer lifting motor at a distance specified by the operator.
 - e. Turns on the buffer drive motor to start rotating the buffer brush and turns on the dispersion motor to start rotating the dispersion roller.
 - f. Tells the conditioning system to inject conditioner onto the lane surface according to the user’s selected pattern.
3. The machine continues at a steady forward speed and the control system:
 - a. Stops the buffer drive and dispersion motors and raises the buffer brush at the end of the user specified conditioner pattern.
 - b. Pulses the cleaner spray off at the end of the lane.
 - c. Stops the machine at the end of the lane after the end of lane sensor is activated.
 - d. Winds the duster cloth to the up position, and advances more cloth for use on the next lane.
 - e. Lifts the squeegee into the up position.
4. The traction drive motor is turned on in reverse to accelerate the machine toward the foul line and the control system:
 - a. Lowers the buffer brush and turns on the buffer drive and dispersion motors to rotate the brush and dispersion roller once the machine reaches the proper position in the conditioner pattern.

- b. Stops at the foul line, turns off the brush and dispersion motors, and lifts the buffer brush.
- c. Turns off the vacuum motor.
- d. Turns on the conditioner pump and conditioner vent valve to slightly over-pressurize the conditioning system (accumulator and injector rail assembly) and then turns off.
- e. Opens the conditioner pressure control valve and conditioner vent valve to allow conditioner to flow back to the conditioner supply tank until the system has reached target pressure.

The Cleaning System

Although the cleaning and conditioning operations work simultaneously, they are described separately to simplify the explanation of operation.

1. The duster cloth removes dust and dirt from the lane surface. Refer to Figure 6-1.

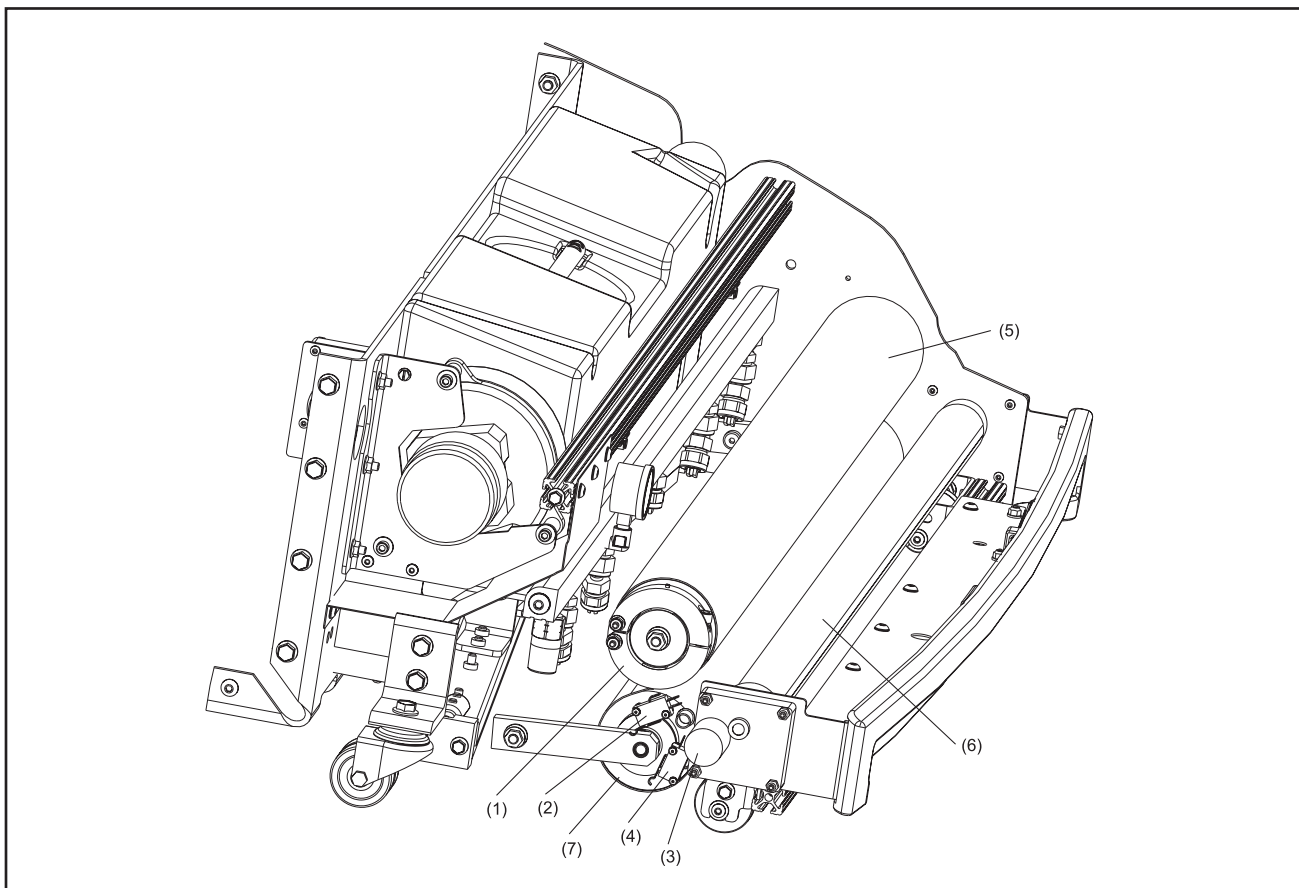

Figure 6-1. Duster Cloth System

- | | | |
|---------------------------|------------------------------|------------------------------|
| (1) DUSTER CLUTCH | (2) DUSTER UP SWITCH | (3) DUSTER CLOTH MOTOR |
| (4) DUSTER DOWN SWITCH | (5) DUSTER CLOTH SUPPLY ROLL | (6) DUSTER CLOTH TAKEUP ROLL |
| (7) DUSTER CONTACT ROLLER | | |

- a. The duster cloth motor unwinds the duster cloth take-up roll to allow the duster contact roller to lower under its own weight until it engages the duster down switch.
 - b. The duster cloth dusts the lane surface as the machine travels toward the pin deck.
 - c. When the machine reaches the end of the lane, the duster cloth take-up roll winds up, creating tension in the cloth that lifts the duster cloth contact roller until it reaches the duster up switch (a friction clutch attached to the duster cloth supply roll is adjusted to ensure the contact roller reaches a fixed stop in the “up” position before it unrolls).
 - d. The duster cloth take up roll continues to rotate to advance clean duster cloth for use on the next lane.
2. The cleaner pump applies cleaning fluid to the lane. Refer to Figure 6-2.
- a. Five spray nozzles apply a continuous spray of cleaning fluid to the lane.
 - b. A spring-loaded check valve opens when more than 10 psi of cleaning fluid is supplied by the pump.
 - c. A cleaner bypass valve and white pinch valve controls the cleaner volume and pressure (allowing you, through the GUI programming, to select the distance along the lane at which the cleaner spray stops and transitions from higher to lower flow).
 - d. The control system turns off the cleaning pump when the machine crosses the front of the pin deck. It quickly sprays one time on the pin deck before stopping the flow of cleaner through the spray nozzles.

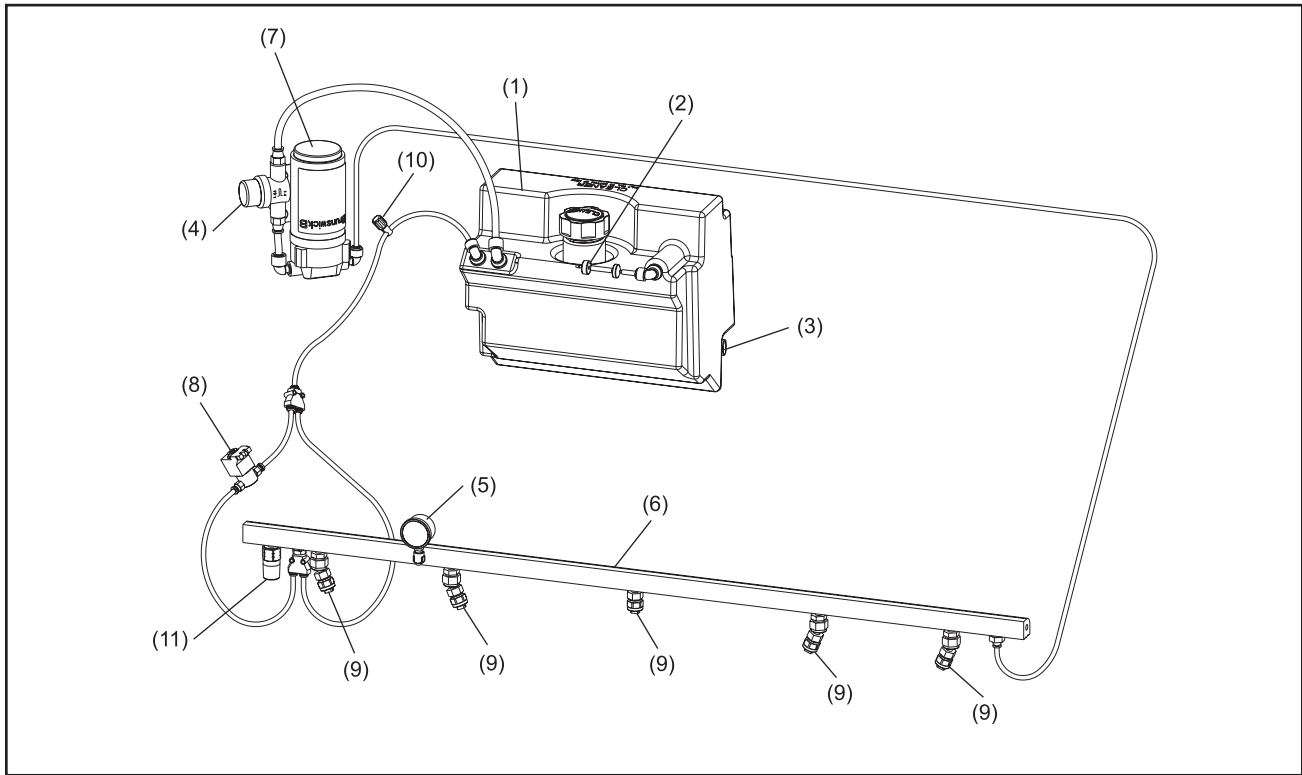

Figure 6-2. Cleaner Spray System

- | | | |
|---------------------------|------------------------------|-----------------------------------|
| (1) CLEANER SUPPLY TANK | (2) CLEANER VENT VALVE | (3) CLEANER LEVEL
FLOAT SENSOR |
| (4) CLEANER SCREEN FILTER | (5) CLEANER PRESSURE GAUGE | (6) CLEANER MANIFOLD |
| (7) CLEANER PUMP | (8) CLEANER BYPASS VALVE | (9) CLEANER SPRAY
NOZZLES |
| (10) PINCH VALVE | (11) CLEANER PRESSURE SENSOR | |

3. The absorbent wiper agitates the cleaning fluid on the lane to help loosen dirt and conditioner. Refer to Figure 6-3.

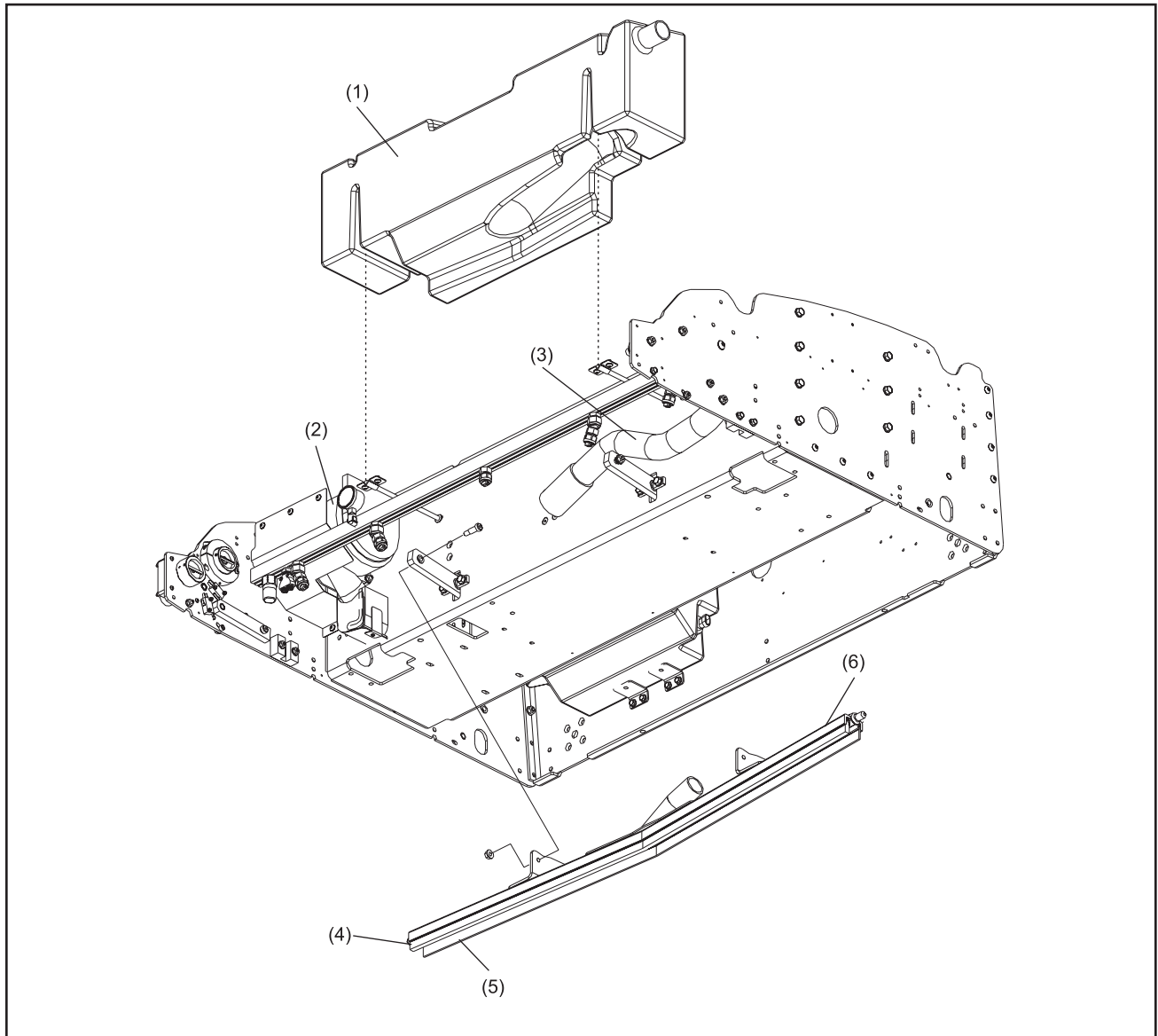

Figure 6-3. Cleaner Vacuum System - Bottom View

- | | | |
|-------------------------|---------------------------|----------------------------|
| (1) WASTE RECOVERY TANK | (2) VACUUM MOTOR ASSEMBLY | (3) WASTE HOSE |
| (4) ABSORBENT WIPER | (5) SQUEEGEE BLADE | (6) SQUEEGEE HEAD ASSEMBLY |

4. The squeegee assembly and vacuum remove cleaner and conditioner from the lane surface and collect it in the waste recovery tank. Refer to Figure 6-3.
 - a. The squeegee blade channels waste fluid to the center of the squeegee assembly.
 - b. Waste fluid is suctioned to the waste recovery tank.
 - c. A baffle system in the waste recovery tank directs waste liquids and solids to the bottom of the tank. This isolates the waste material away from the vacuum motor.

The Conditioning System

1. The machine applies conditioner directly to the lane surface in a pattern specified by the user. Refer to Figure 6-4.

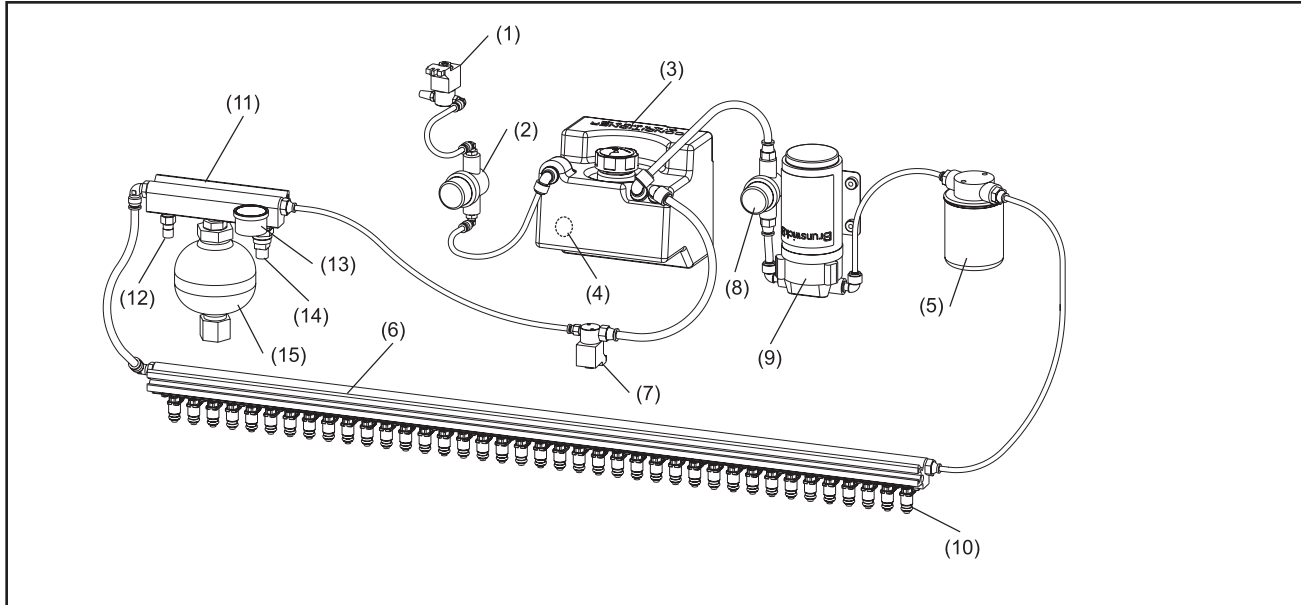

Figure 6-4. Conditioning System

(1) CONDITIONER VENT VALVE	(2) CONDITIONER OVERFLOW RESERVOIR	(3) CONDITIONER SUPPLY TANK
(4) CONDITIONER LEVEL FLOAT SENSOR	(5) CONDITIONER SPIN-ON FILTER	(6) INJECTOR RAIL ASSEMBLY
(7) CONDITIONER PRESSURE CONTROL VALVE	(8) CONDITIONER SCREEN FILTER	(9) CONDITIONER PUMP
(10) CONDITIONER INJECTOR	(11) ACCUMULATOR RAIL	(12) CONDITIONER TEMPERATURE SENSOR
(13) CONDITIONER PRESSURE GAUGE	(14) CONDITIONER PRESSURE SENSOR	(15) ACCUMULATOR

- a. 39 injectors mounted on a pressurized rail apply conditioner directly onto the lane.
- b. The rail is fixed (i.e. the injectors do not reciprocate from side to side) to avoid creating a zigzag conditioner pattern on the bowling lane.
- c. Each injector disperses fluid across the approximate width of one board of the lane and is independently controlled based on the conditioning pattern selected.

- d. Injectors pulse every 0.1 feet (30.5 mm) (pulse pattern is distance based, not dependent on machine's rate of travel).
- e. The pressure of the conditioning system is set before the first lane as described previously in this section, "Preparing for Operation". The pressure of the conditioning system is then reset as soon as the lane machine returns to the foul line so it is ready for the next lane.



NOTE:

Allow the conditioning system to depressurize by waiting at least one minute before unplugging or turning off the lane machine after completing the last lane. Troubleshooting Using the GUI.

The Buffing Operation

1. During the forward travel of the buffing operation, the machine disperses the conditioner on the lane surface and buffs it, then continues its return travel to the foul line. Refer to Figure 6-5.

- (1) BUFFER BRUSH
- (2) DISPERSION ROLLER
- (3) BUFFER LIFTING MOTOR
- (4) DISPERSION ROLLER MOTOR
- (5) BUFFER DRIVE MOTOR
- (6) BUFFER DRIVE BELT

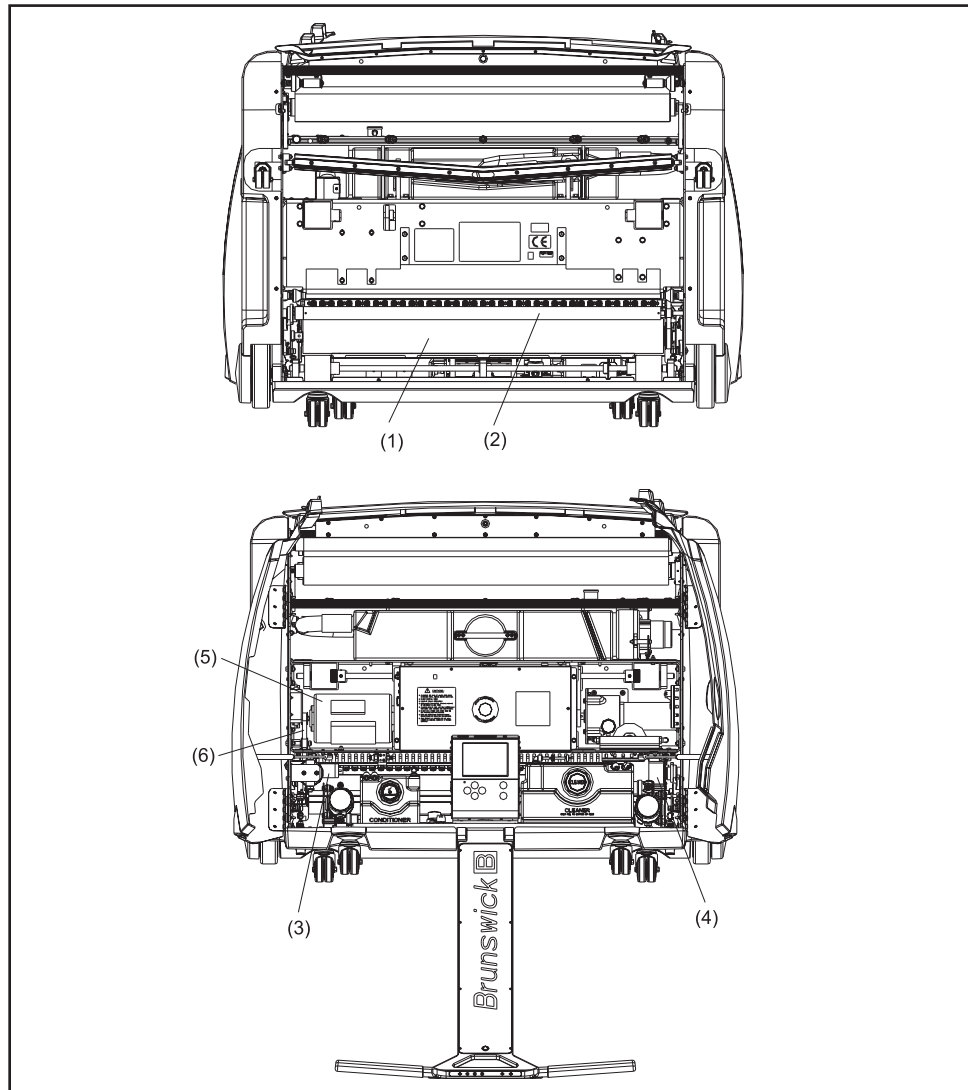

Figure 6-5. Buffing System

- a. The buffer brush lowers at the selected starting pattern distance and begins rotating.
- b. The dispersion roller, rotating in the same direction as the buffer brush, contacts the buffer brush and blends the conditioner amongst the bristles through side-to-side oscillation.
- c. When the machine reaches the end of the selected conditioning pattern distance, the control system stops the rotation of the buffer brush and dispersion roller. It turns on the buffer lift motor and raises the brush up and out of contact from the lane as the machine continues its travel to the pin deck when in the “Clean” and “Oil” mode.

The Traction Drive System

1. The machine travels up and down the lane by means of a traction drive motor connected through a chain to two drive wheels. Refer to Figure 6-6.
 - a. At the optional “Quick Clean” speed, the machine travels at a constant 27 inches per second.
 - b. At “Max Clean” speed the machine travels at a constant 21 inches per second. This option is used to optimize lane cleaning.

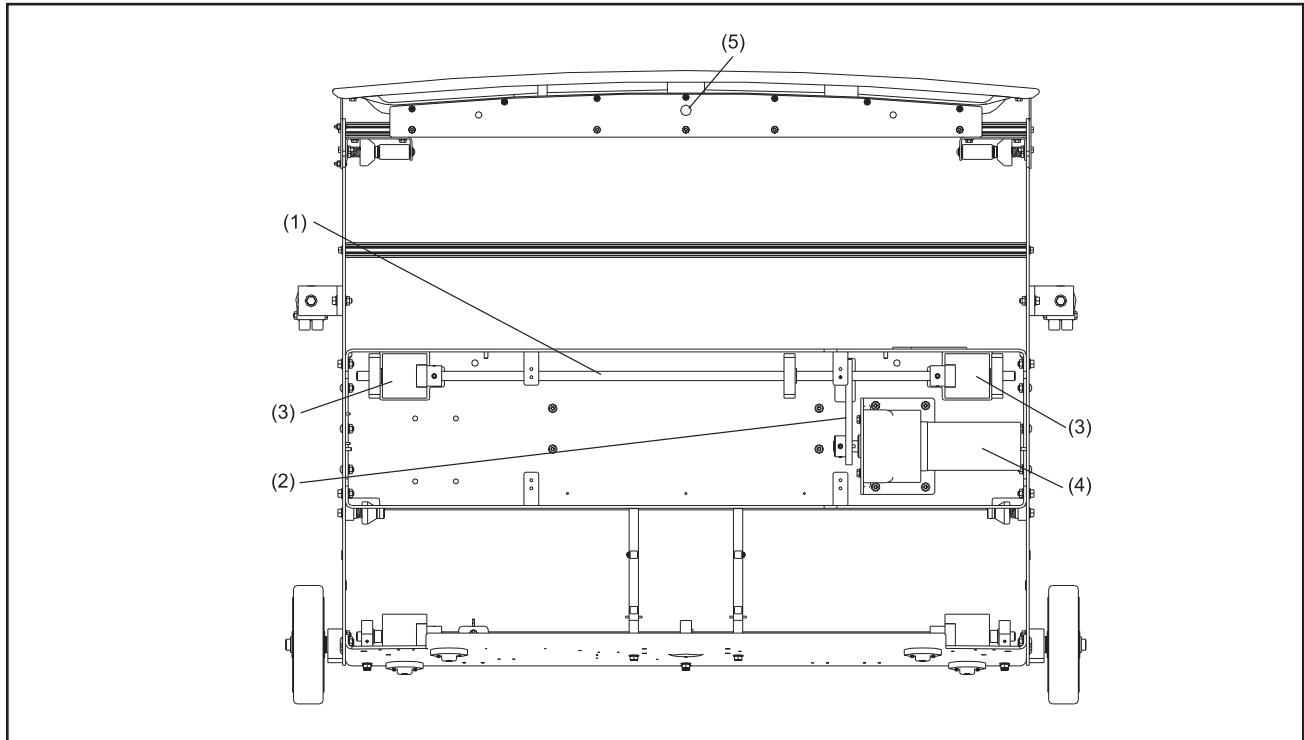

Figure 6-6. Traction Drive System

- | | | |
|--------------------------------|--------------------------|---------------------------|
| (1) TRACTION WHEEL DRIVE SHAFT | (2) TRACTION MOTOR CHAIN | (3) TRACTION DRIVE WHEELS |
| (4) TRACTION DRIVE MOTOR | (5) END OF LANE SENSOR | |

For information on how to change the travel speed, see Section 4.

2. Forward travel.
 - a. The machine travels forward at a constant 21 inches per second (or 27 inches per second at optional quick clean speed).
 - b. As the front of the machine travels past the end of the pin deck, the end-of-lane sensor signals the controller to travel an additional 1.2 feet (36.5 cm) before applying the brake.
 - c. The squeegee head assembly raises.

- d. The duster cloth motor rotates the take-up roll to raise the contact roller away from the lane surface until it contacts the duster up switch.
 - e. The take-up roll continues to rotate to advance clean cloth for use on the next lane.
 - f. The traction drive motor turns on to accelerate the machine back to the foul line.
3. Return to the foul line.
 - a. The machine returns to the foul line in reverse travel at a constant travel speed.
 - b. The buffer brush lowers into contact with the lane surface at the end of the lane pattern to continue buffing conditioner on the return to the foul line (no conditioner is applied on the return).



NOTE:

If the conditioner values in the last pattern zone equal zero, the buffer brush will not lower until reaching the next to last zone.

- c. As a safety precaution, the machine is designed to decelerate as it reaches the foul line.
- d. Once the machine reaches the foul line, the conditioner system prepares the pressure and the GUI displays the number of the next lane to be maintained.

Troubleshooting Using the GUI

The GUI is a very helpful tool to use for troubleshooting machine issues that may occur from time to time. In the “Maintenance” menu you can enter the “Diagnostics” sub menu, of the lane machine, and have a choice of selections for “Sensors”, “Cleaning”, “Conditioning”, “Drive”, and “Tests”. Within each of the choices, you have sensory components and motor functions that can be tested to check the status and functionality.

1. Place the machine in the operator position and supply power.
2. Navigate to the “Maintenance” menu and press “OK”.
3. Navigate to the Diagnostics sub menu and press “OK”.

The screen will now display your “Diagnostics” options that are broken into each system of the lane machine. Refer to Figure 6-7.

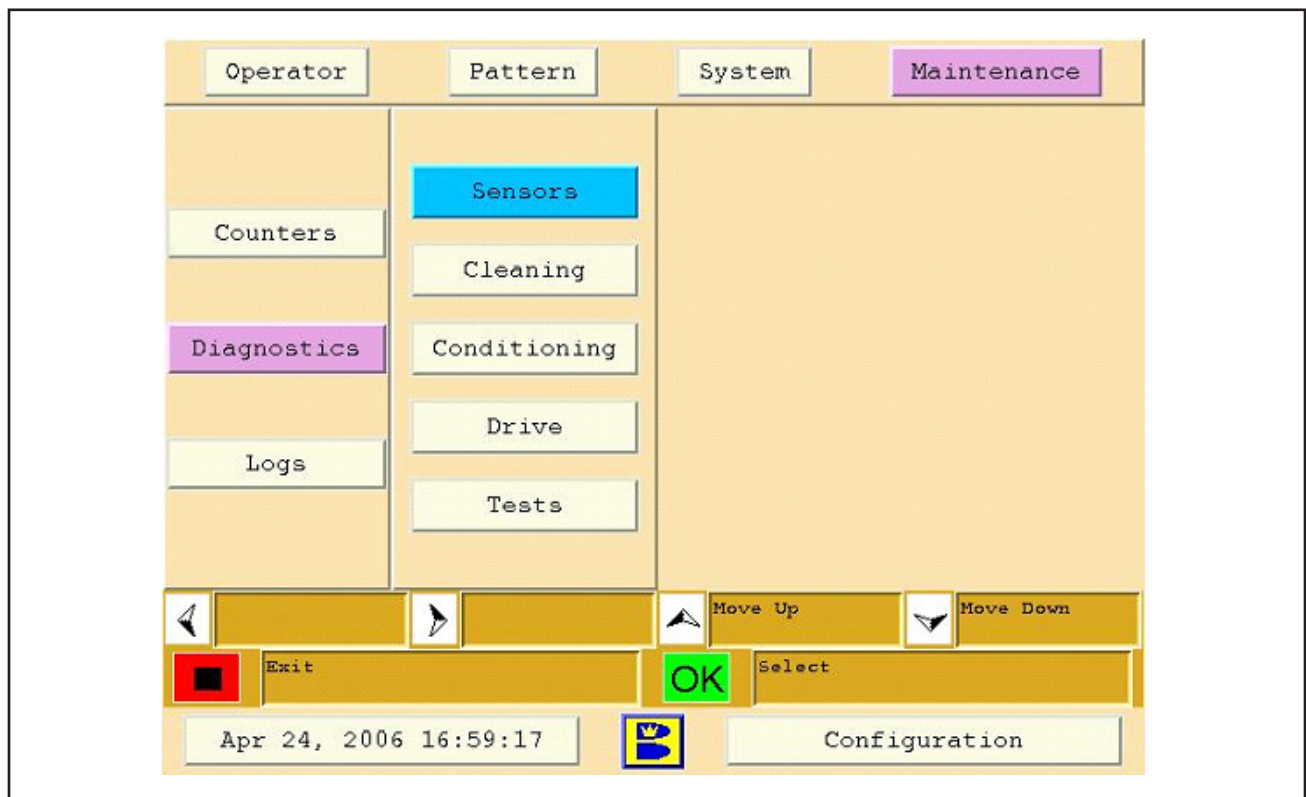

Figure 6-7. Diagnostics

Sensors

The “Sensors” diagnostic screen displays the current status of all sensors and switches used in the lane machine. Refer to Figure 6-8. The display can inform you of the position of a motor or components, such as the “squeegee up”, or can give you a digital reading, such as the temperature or pressure sensors. To test a particular sensor or switch, you can manually activate it by engaging the plunger on the switch or spinning the rear shaft to activate the "speed" encoder. Certain functions can also be tested through the diagnostics for the “Cleaning”, “Conditioning”, and “Drive” systems. Refer to Figure 6-7.

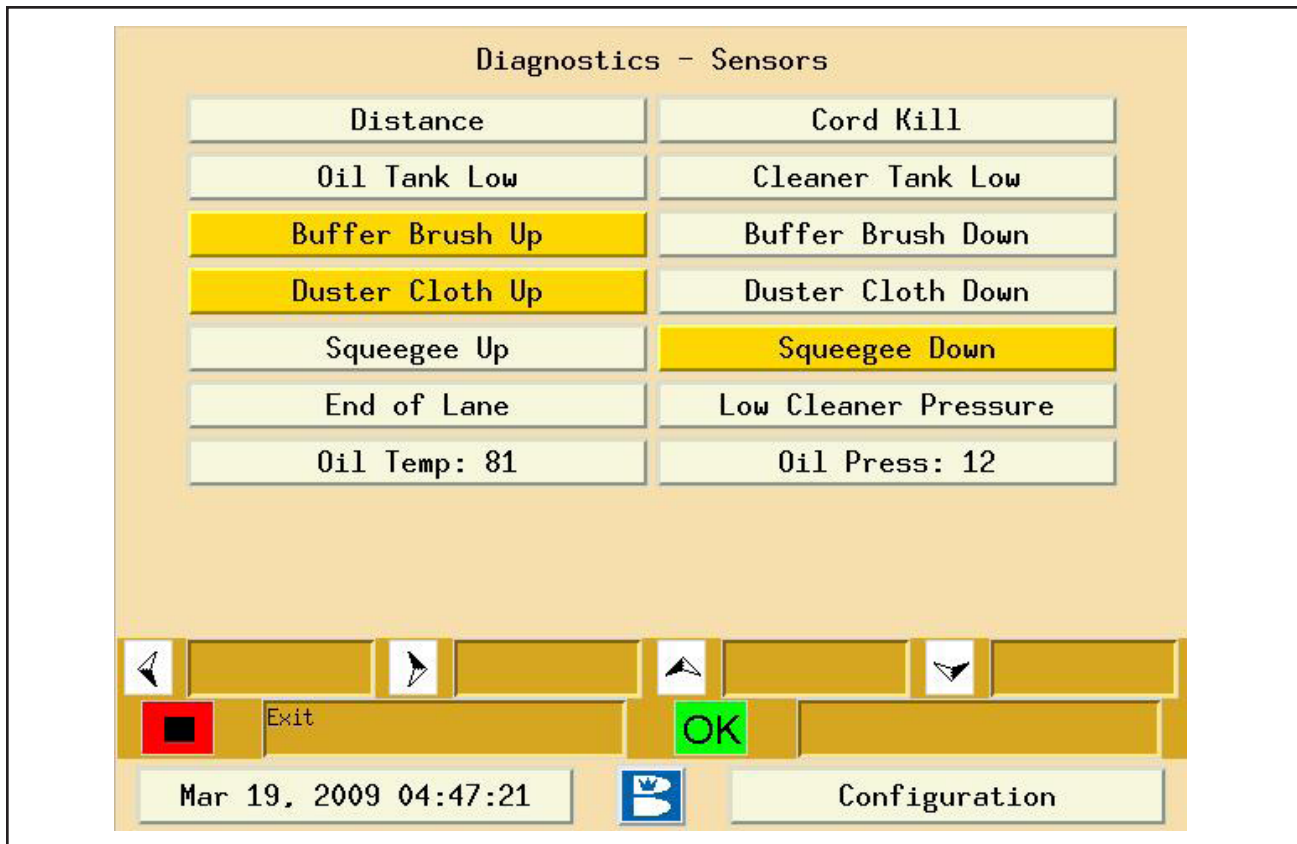

Figure 6-8. Diagnostics - Sensors

1. Use the *up* and *down* arrows to highlight “Sensors” and press “OK”.
2. Identify the sensor that is suspect to failure.
3. Physically actuate the switch or sensor and the sensor status will be displayed.

Sensors, such as the fluid level sensors, can only be checked by draining and filling the tank. However, if the Warning message appears and the tank is full, there may be a failure of the sensor.

Cleaning

The “Cleaning” diagnostics screen is split into 2 sections. The top section displays the sensors and current status used in conjunction with the cleaning system (sensors include squeegee and duster position, cleaner fluid level sensor). The bottom section displays the motor functions (vacuum, cleaner pump, duster motor) that can be selected and tested for either a period of up to 20 seconds or may be toggled between positions (Toggle Squeegee). Any timed function can be turned off in less than the remaining 20 seconds by pressing “OK”. Multiple functions may be turned on at the same time (cleaner pump and cleaner valve – to check Min spray pressure). Refer to Figure 6-9.

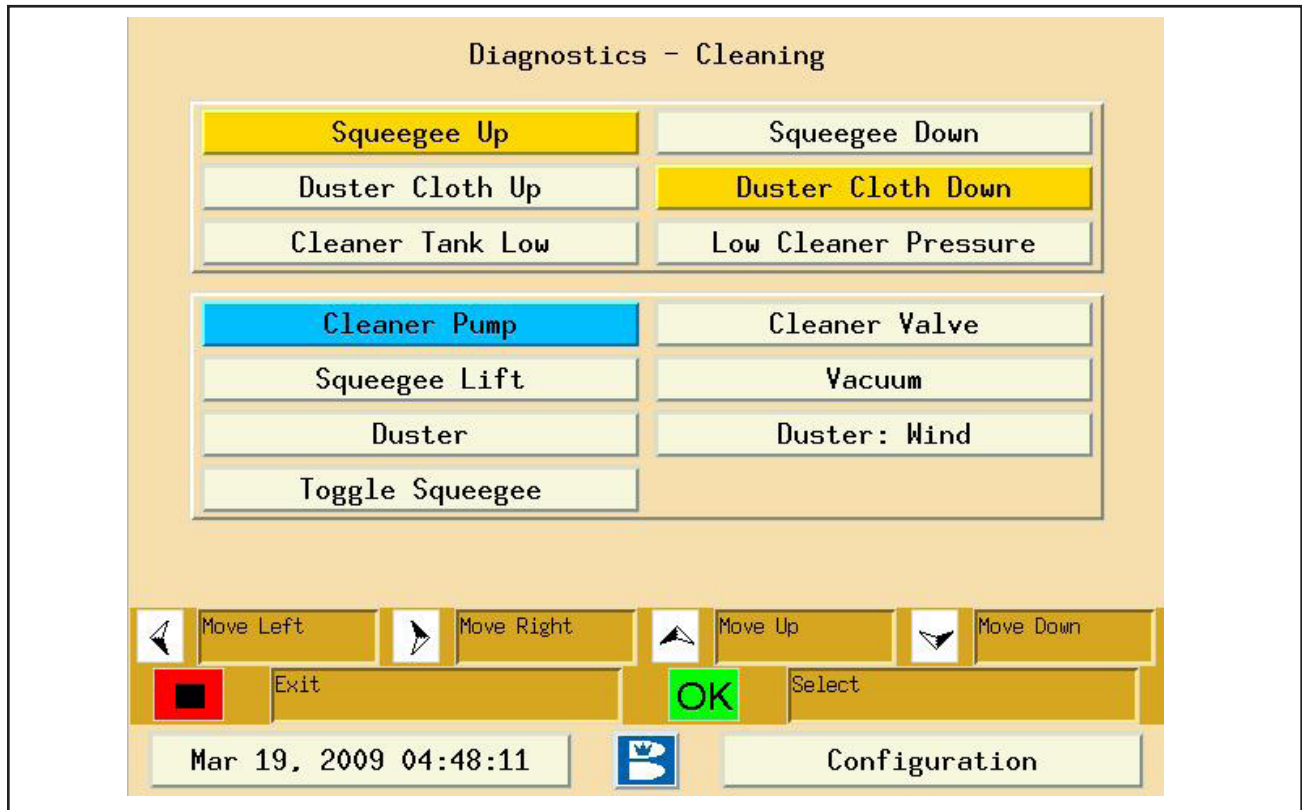

Figure 6-9. Diagnostics - Cleaning



CAUTION!

Do not operate cleaner pump with the machine on the approach.

1. Use the *up* and *down* arrows to highlight “Cleaning” and press “OK”.
2. Identify and navigate to the motor function that is suspect to failure.
3. Press “OK” and the component will run for 20 seconds and shut off, except for the “Toggle Squeegee” button which moves between the squeegee up and down switches. Any timed function can be turned off in less than the remaining 20 seconds by pressing “OK”.

Sensors will highlight when a motor function related to the sensor is activated.

Conditioning

The “Conditioning” diagnostics screen is also split into 2 sections. The top section displays the sensors and current status used in conjunction with the conditioning system (sensors include buffer position, temperature, pressure, and conditioner supply tank level sensor). The bottom section displays the motor functions (buffer drive and lift motors, conditioner pump, heater, and dispersion motor) that can be selected and tested for either a period of up to 20 seconds or may toggle (Toggle Buffer up/down) between positions. Multiple functions may be turned on at the same time (**always turn on the “Oil Tank Vent” whenever running the “Oil Pump” or the “Oil Press Valve”**). Refer to Figure 6-10.

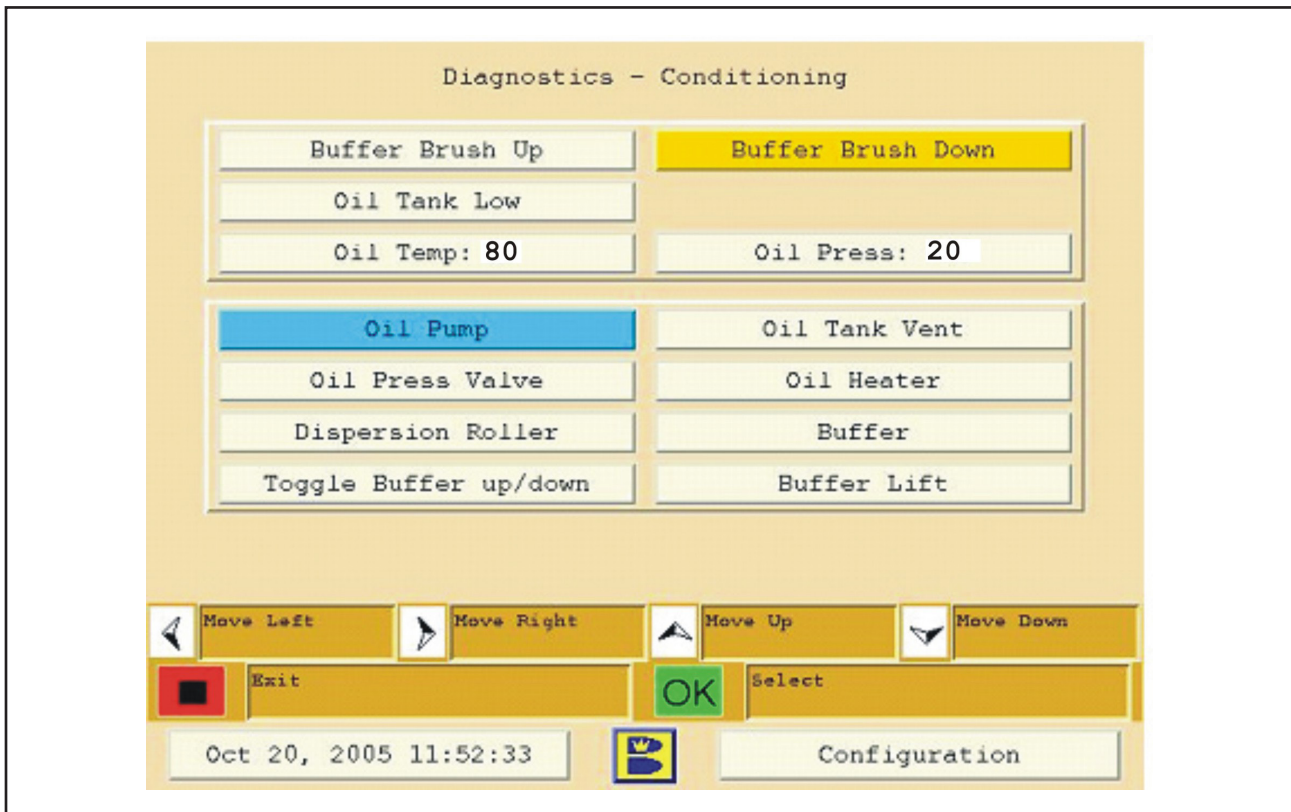

Figure 6-10. Diagnostics - Conditioning

1. Use the up and down arrows to highlight “Conditioning” and press “OK”.
2. Identify and navigate to the motor function that is suspect to failure.
3. Press “OK” and the component will run for up to 20 seconds and shut off except for the “Toggle Buffer up/down” button which moves between the buffer brush up and down switches. Any timed function can be turned off in less than the remaining 20 seconds by pressing “OK”.

Sensors will highlight when a motor function related to the sensor is activated.

Drive

The “Drive” diagnostics screen is used to test the traction drive motor. The test can be performed on the lane surface or on the approach. The machine will travel, if on lane, at a slow speed for up to 20 seconds. While it is traveling on the lane, you will notice the distance (speed) encoder sensor button highlighting (on) each time a tooth from the encoder wheel passes the encoder sensor. If you are testing the traction drive motor on the approach, the distance encoder sensor will not transition between on and off unless the rear shaft is rotated by hand. Refer to Figure 6-11.

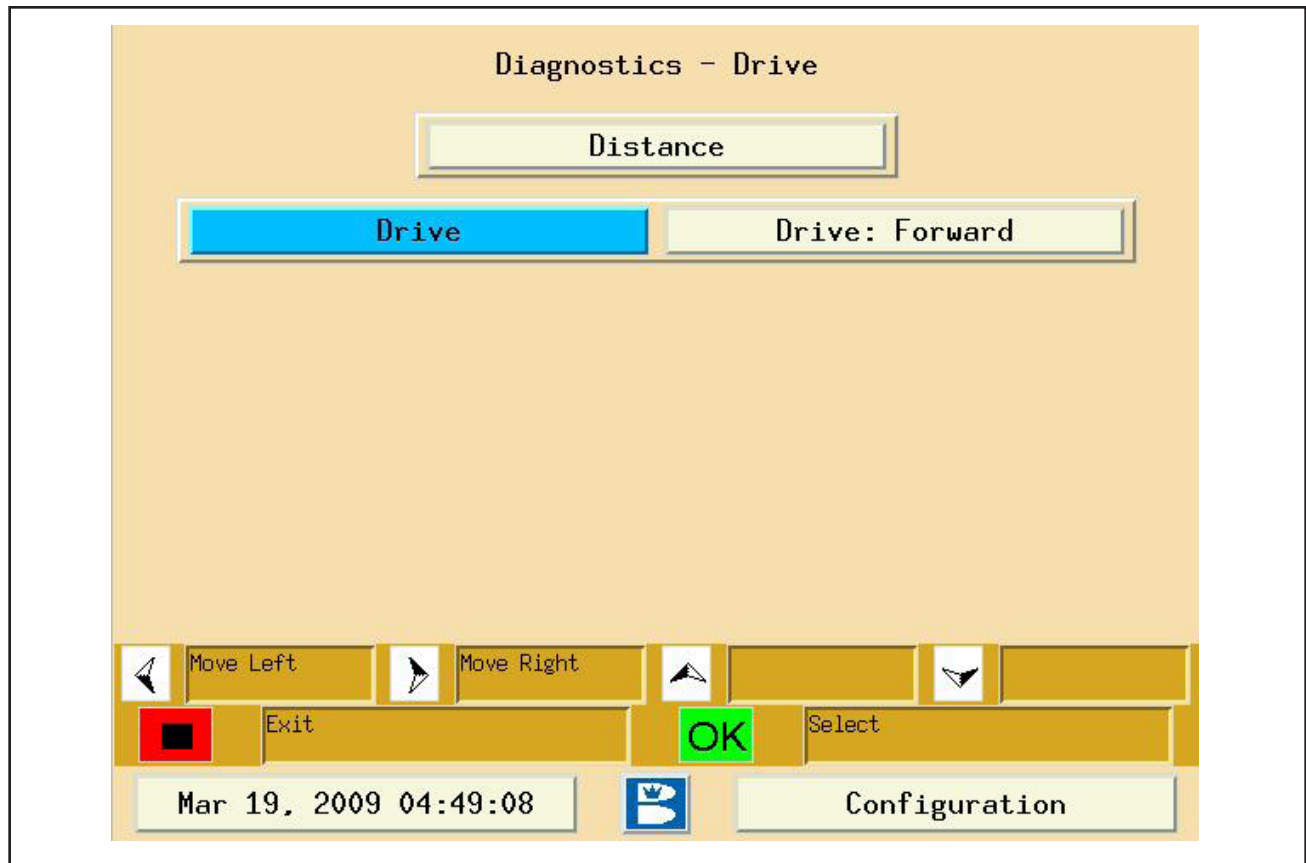

Figure 6-11. Diagnostics - Drive

1. Use the *up* and *down* arrows to highlight “Drive” and press “OK”.
2. Navigate, using the *left* and *right* arrows, to the “Drive: Forward” and select either forward or reverse by pressing “OK”.
3. Navigate back to “Drive” and press “OK” and the drive motor will run for 20 seconds. Any timed function can be turned off in less than the remaining 20 seconds by pressing “OK”.

Tests

The “Tests” diagnostic screen allows you to test the “Oil injectors” and the “Cleaner spray”. In the event that an oil injector or a cleaner spray nozzle is suspect to failure, you may perform these tests to visually inspect the spray patterns and identify an issue, without the interference of the buffer brush or squeegee assemblies. Refer to Figure 6-12.

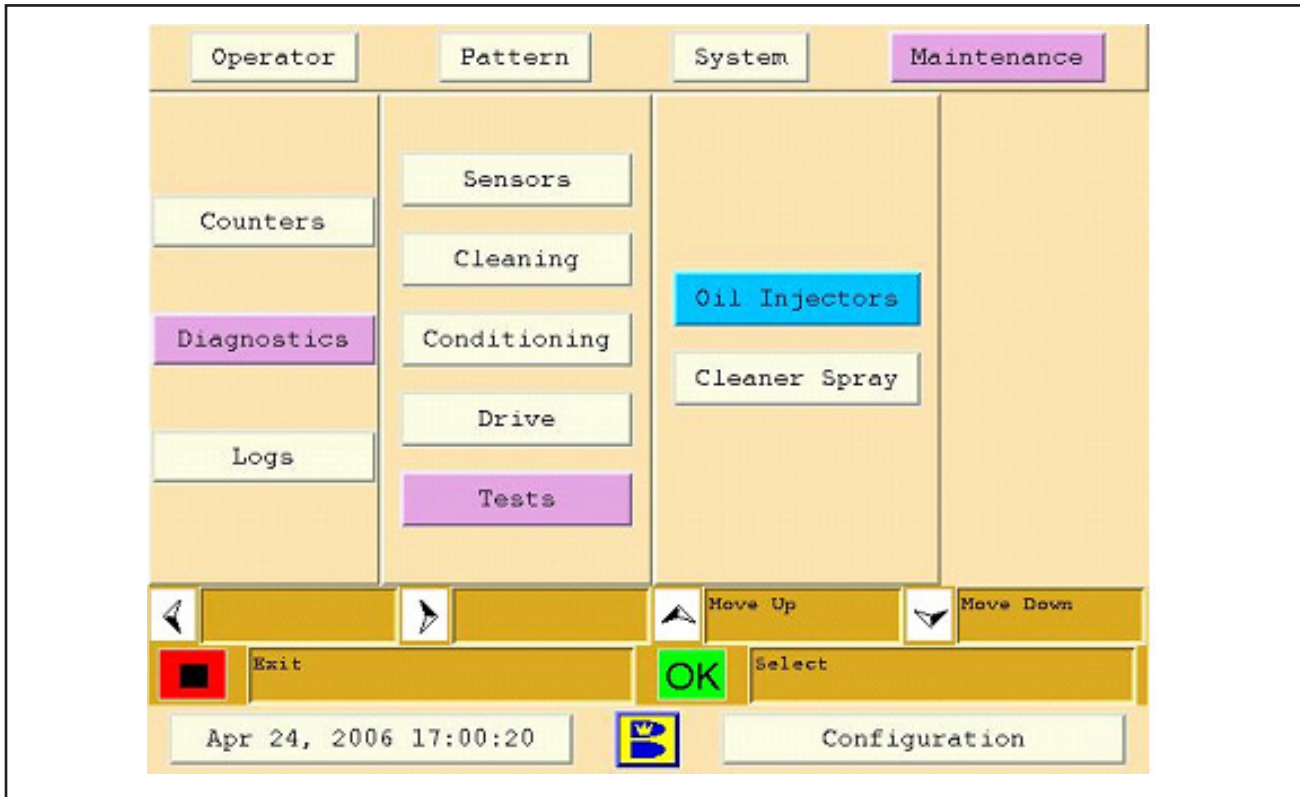

Figure 6-12. Diagnostics - Tests

“Oil Injectors” diagnostics function allows the user to perform specific tests on the injectors to verify that all injectors are firing properly. Refer to Figure 6-13.

The test for the Oil Injectors is designed for the technician to visually see each injectors spray pattern. This diagnostic function verifies that each injector is firing properly and to identify if an injector has failed or not creating the appropriate spray pattern. The machine will travel approximately 25 feet down the lane during this test. The process includes cleaning the lane and firing each injector in a sequential order allowing the technician to easily see each injection without interference by the buffer brush.

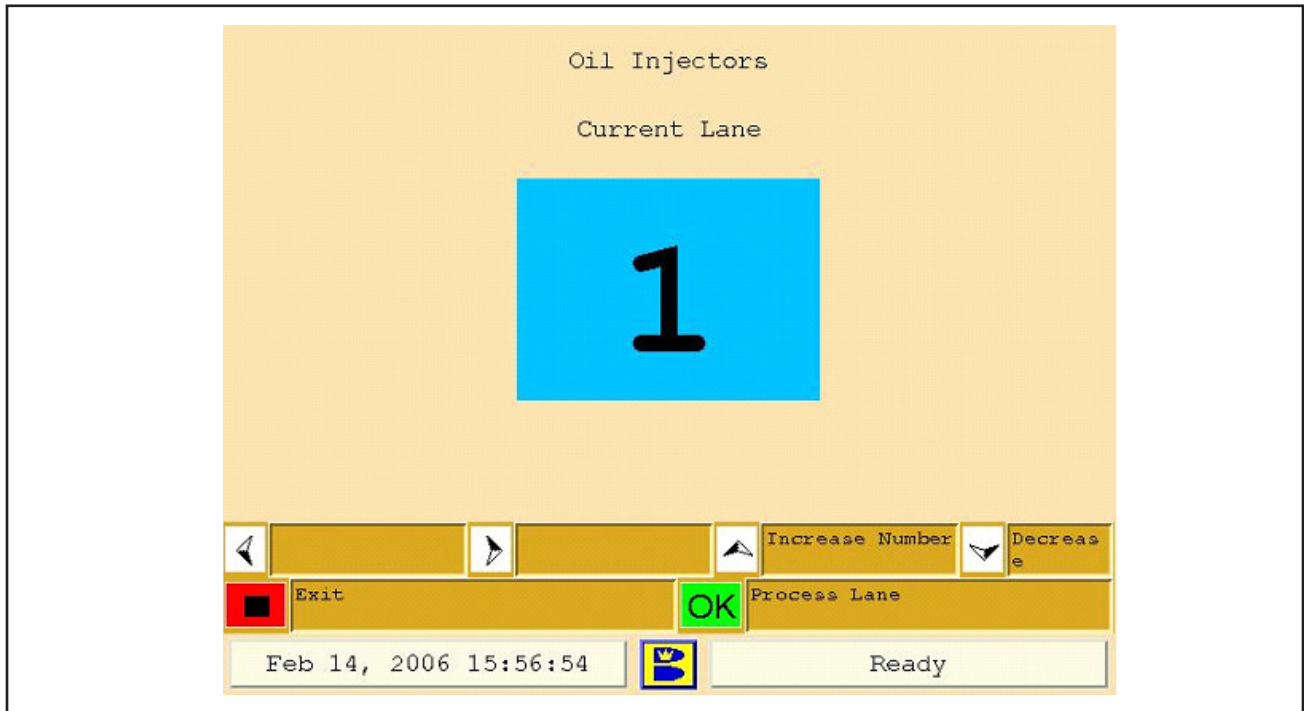

Figure 6-13. Oil Injectors

1. Use the *up* and *down* arrows to highlight “Tests” and press “OK”.
2. Use the *up* and *down* arrows to select “Oil Injectors” and press “OK”.
3. Press “OK” to prepare the lane machine to run a lane. The injector test pattern may need to be downloaded.
4. “Put the lane machine on the lane” when instructed.
5. Press “OK” to start the cleaning operation of the “Oil Injectors” test. The machine will automatically clean approximately the first 25 feet of the bowling lane and inject at the same time while performing this test. Perform a clean only or a clean and condition after completion of the Oil Injector test.



NOTE:

After test is completed it will be necessary to clean and recondition the lane with the appropriate conditioner pattern.

“**Cleaner Spray**” test for the Cleaner spray is used to verify the coverage for both the maximum and minimum spray pressures. This test allows the technician to visually see how well the cleaning spray is covering the lane during a cleaning run. The process is performed in two passes of the lane machine. The first pass of the machine will clean approximately 25 feet of the bowling lane. The second pass sprays cleaner to the bowling lane as it travels without interference of the duster and the squeegee assembly. The cleaner will transition from maximum to minimum about half way through the second run. Refer to Figure 6-14.

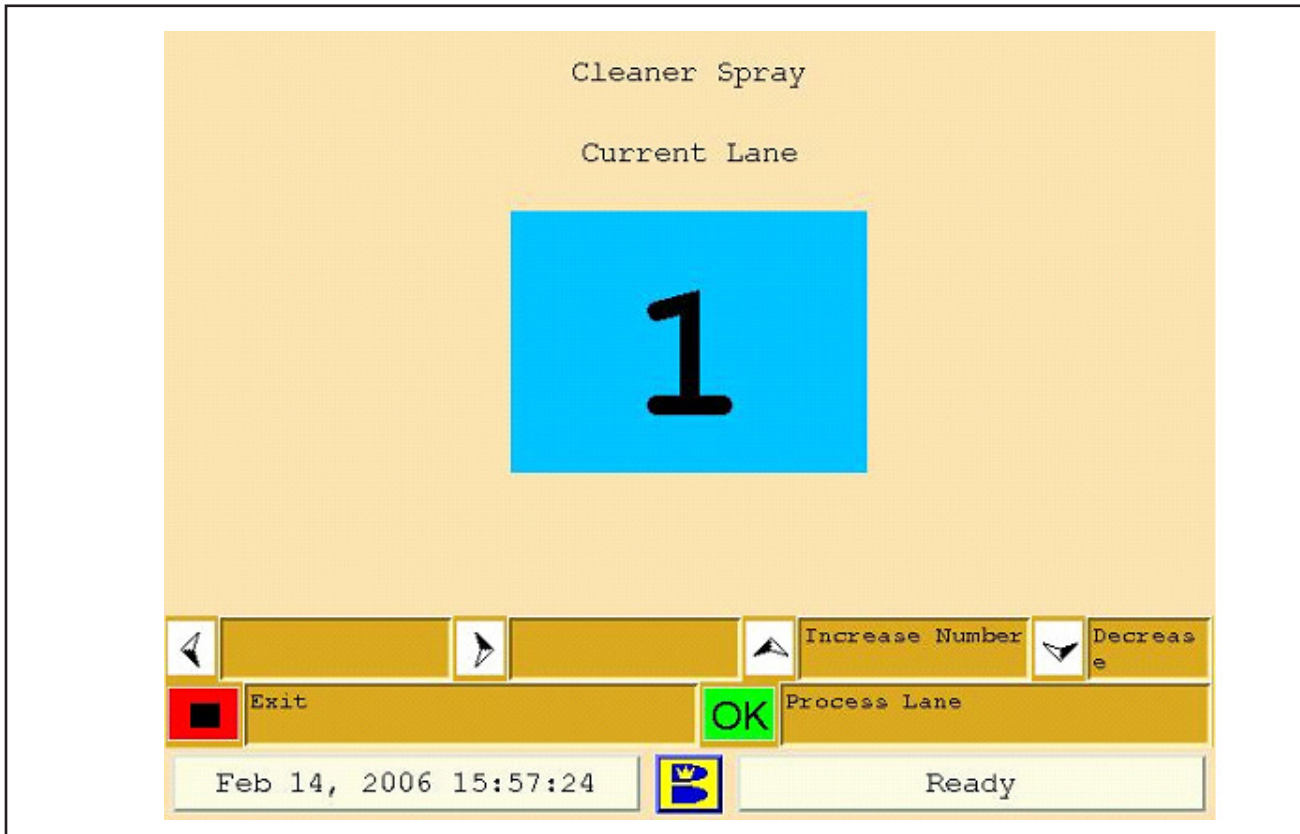

Figure 6-14. Cleaner Spray

1. Use the *up* and *down* arrows to highlight “Tests” and press “OK”.
2. Use the *up* and *down* arrows to select “Cleaner Spray” and press “OK”.
3. Press “OK” to prepare the lane machine to run a lane.
4. “Put the lane machine on the lane” when instructed.
5. Press “OK” to start the cleaning operation of the “Cleaner Spray” test.
6. Press “OK” when the machine returns to the foul line, this will start the cleaner spray coverage test.



NOTE:

DO NOT allow cleaner to completely dry on lane surface. After test is completed it will be necessary to clean and recondition the lane with the appropriate conditioner pattern.

Error Messages

Error messages appear on the GUI if the lane machine fails during preparation or operation. Some errors allow you to continue operation. Some require immediate attention, especially those that affect the consistency and performance of a conditioner pattern. In such cases, you may need to recondition a lane after correcting the error.

The images in Figure 6-15 are examples of possible error messages the GUI may display during preparation.

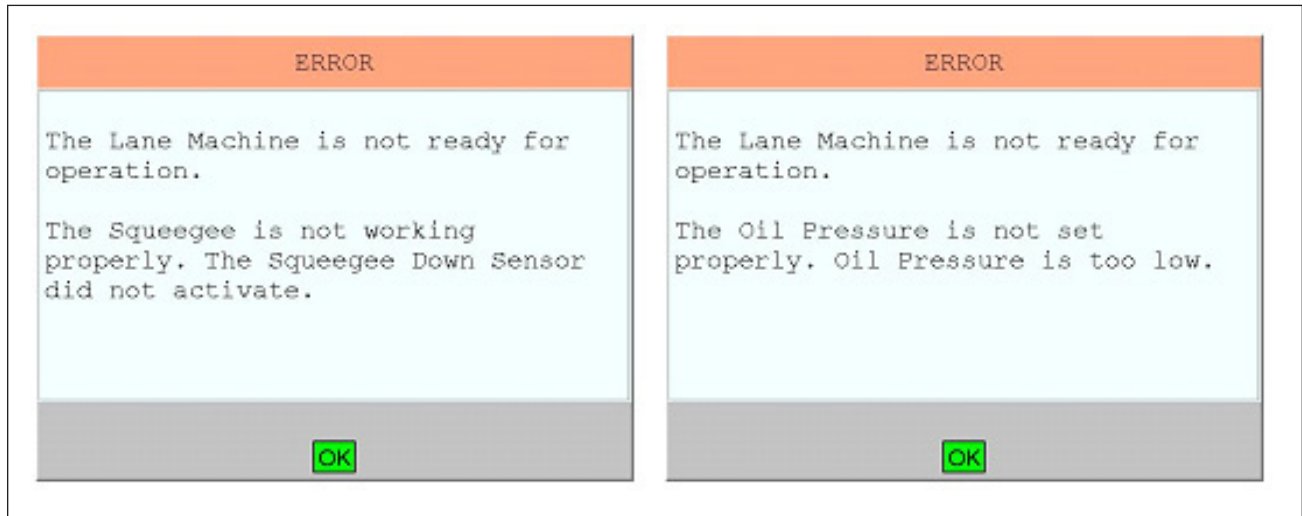

Figure 6-15. Error Messages - Preparation

The images in Figure 6-16 are examples of possible error messages the GUI may display during operation.

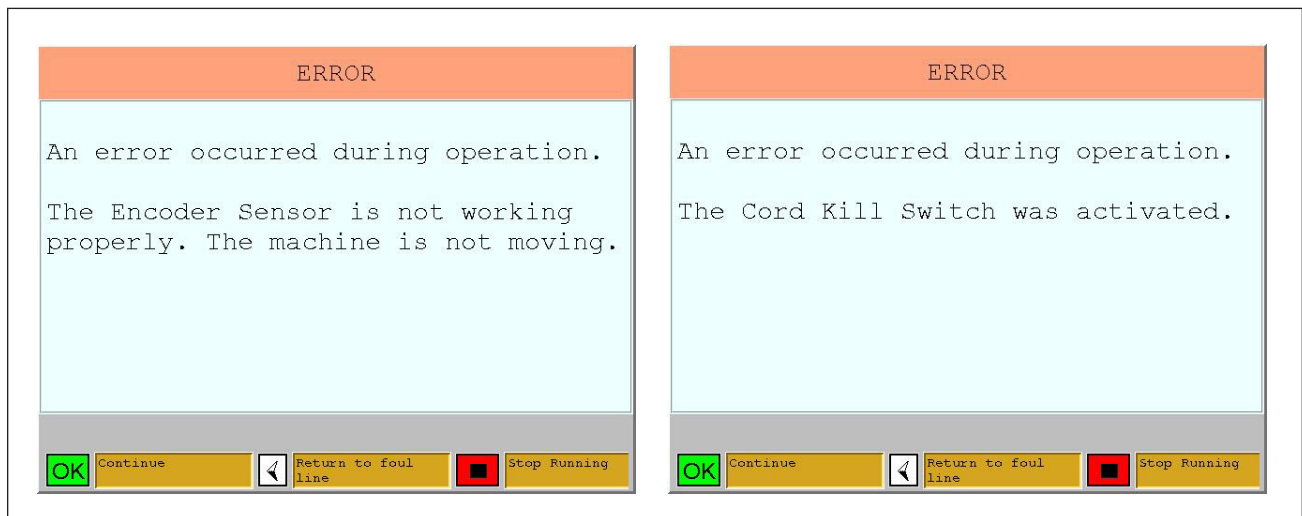

Figure 6-16. Error Messages - Operation

Tables 6-1 through 6-13 provide a list of error messages with potential problems and remedies. If using the Authority22's Diagnostics menu does not resolve your problem, please contact your authorized Distributor or the Brunswick Customer Response Center (CRC) in the United States at 1-800-YES-BOWL, or internationally at 231-725-4966. For non emergency support, e-mail crcsupport@brunbowl.com

List of Error Messages

Error Messages that Appear During Preparation (on approach)

Error Message - Table 6-1:

The lane machine is not ready for operation.
The duster cloth is not working properly. The Duster Cloth down sensor did not activate.

Error Message - Table 6-2:

The lane machine is not ready for operation.
The squeegee is not working properly. The squeegee down sensor did not activate.

Error Message - Table 6-3:

The lane machine is not ready for operation.
The oil pressure is not set properly. The oil pressure is too low.

Error Message - Table 6-4:

The lane machine is not ready for operation.
The oil pressure is not set properly. The oil pressure is too high.

Error Message - Table 6-5:

A communication error occurred.

Error Messages that Appear During Operation (on lane)

Error Message - Table 6-6:

An error occurred during operation.
The Encoder Sensor is not working properly. The machine is not moving.

Error Message - Table 6-7:

An error occurred during operation.
The Cord Kill Switch is not working properly. The Cord Kill Switch was activated.

Error Message - Table 6-8:

An error occurred during operation.
The Buffer Brush is not working properly. The Buffer Brush down sensor was not activated.

Error Message - Table 6-9:

An error occurred during operation.
The Buffer Brush is not working properly. The Buffer Brush up sensor did not activate.

Error Message - Table 6-10:

An error occurred during operation.
The Squeegee is not working properly. The Squeegee Up sensor did not activate.

Error Messages - Table 6-11:

An error occurred during operation.
The Duster cloth is not working properly. The Duster cloth up sensor did not activate.

Error Message - Table 6-12:

An error occurred during operation.
The End of Lane Sensor is not working properly.

Error Message - Table 6-13:

Other error messages.

Error Messages that Appear During Preparation (on approach)

Error Message - Table 6-1:

The lane machine is not ready for operation.
The duster cloth is not working properly. The Duster Cloth down sensor did not activate.



NOTE:

Verify error source through GUI diagnostics.

What you may observe	Potential problem	Action
1. Duster cloth is down and contacting the switch	1. Broken wire or loose connection at switch or at the electronic enclosure 2. Failed switch	1. Repair connection 2. Verify switch function using GUI diagnostics and replace if necessary
2. Duster cloth is down and not contacting the switch	1. Switch has come out of adjustment 2. Duster contact roller is binding	1. Re-adjust switch so it actuates when cloth is in its full down position 2. Check duster assembly for damage; check for loose hardware
3. Duster Cloth is up and did not lower	1. The duster cloth is routed incorrectly on the take-up core 2. Broken wire or loose connection at motor or at the electronic enclosure 3. Duster motor failure	1. Refer to adjustments in section 4.0 or the diagram located in the Machine 2. Repair connection 3. Verify motor function using GUI diagnostics and replace if necessary

Error Message - Table 6-2:

The lane machine is not ready for operation.

The squeegee is not working properly. The squeegee down sensor did not activate.



NOTE:

Verify error source through GUI diagnostics.

What you may observe	Potential problem	Action
1. Squeegee lift motor cycles until it actuates the up switch	1. Broken wire or loose connection at switch or at the electronic enclosure 2. Failed switch	1. Repair connection 2. Verify switch function using GUI diagnostics and replace if necessary
2. Squeegee is up and did not lower	1. Broken wire or loose connection at motor or at electronic enclosure 2. Loose Cam 3. Squeegee motor failure	1. Repair connection 2. Tighten set screw on the "flat" of the motor shaft 3. Verify motor function using GUI diagnostics and replace if necessary

Error Message - Table 6-3:

The lane machine is not ready for operation.
The oil pressure is not set properly. The oil pressure is too low.



NOTE:
Verify error source through GUI diagnostics.

What you may observe	Potential problem	Action
1. No pressure reading from digital pressure sensor	<ul style="list-style-type: none"> 1. Broken wire or loose connection at sensor or at electronic enclosure 2. Pressure sensor failure 3. Pump does not run 	<ul style="list-style-type: none"> 1. Repair connection 2. Verify sensor function using GUI diagnostics and replace if necessary 3. Option 1: Blown fuse, replace fuse and check wire connections Option 2: Broken wire or loose connection at pump or at the electronic enclosure, repair connection Option 3: Verify pump function using GUI diagnostics and replace if necessary
2. System pressure below limit for required operating pressure	<ul style="list-style-type: none"> 1. Air inside the conditioning system 2. Bad tube fitting connection 3. Oil pressure control valve failure 4. Incorrect accumulator pressure 5. Pump by-pass failure 	<ul style="list-style-type: none"> 1. Cycle conditioner with vent valve and oil pressure control valve open 2. Option 1: make sure tube is cut at 90° angle, Option 2: make sure tubing is seated properly in fitting. If both are correct replace fitting. 3. Verify oil pressure control valve function using GUI diagnostics and replace if necessary. 4. Check for 10 psi pressure at the accumulator (call CRC) 5. Option 1: Adjust by-pass (call CRC); Option 2: Replace pump

Error Message - Table 6-4:

The lane machine is not ready for operation.
The oil pressure is not set properly. The oil pressure is too high.



NOTE:

Verify error source through GUI diagnostics.

What you may observe	Potential problem	Action
1. System pressure above limit for required operating pressure	1. Broken wire or loose connection at oil pressure control valve or at the electronic enclosure 2. Pressure control valve failure 3. Pressure sensor failure	1. Repair connection 2. Verify oil pressure control valve function by using GUI diagnostics and replace if necessary. 3. Verify sensor function using GUI diagnostics and replace if necessary.

Error Messages - Table 6-5:

A communication error occurred.



NOTE:

Verify error source through GUI diagnostics.

What you may observe	Potential problem	Action
1. This error message may occur when the lane machine is on the approach or at the foul line.	1. Broken wire or loose connection between the GUI (com 2 port) and electronics enclosure (user interface connector). 2. Damaged PCB or other electrical problem inside electronics enclosure or GUI.	1. Check connection at either end of cable and repair if necessary 2. Call CRC

Error Messages that Appear During Operation (on the lane)

Error Message - Table 6-6:

An error occurred during operation.

The Encoder Sensor is not working properly. The machine is not moving.



NOTE:

Verify error source through GUI diagnostics.

What you may observe	Potential problem	Action
1. Machine does not move (traction drive wheels slipping)	1. Machine not seated properly onto lane 2. High gutters, bumpers or wide lanes 3. Excess cleaner causing wheels to slip 4. Too much oil 5. Squeegee too low 6. Traction drive wheels binding against frame	1. Reposition Authority22 onto lane surface 2. Option 1: Lower gutters Option 2: Replace or repair bumpers Option 3: Adjust the front/rear transition/guide rollers 3. Check squeegee adjustment <i>See Adjusting the squeegee blade for more information</i> 4. Check pattern settings and conditioner settings 5. Check squeegee adjustment <i>See Adjusting the squeegee blade for more information</i> 6. Check for loose set screws at traction drive wheels
2. Machine does not move (traction drive wheels not turning)	1. Blown fuse 2. Broken wire or loose connection at motor or at the electronic enclosure 3. Traction drive motor failure	1. Replace fuse and check wire connections 2. Repair connection 3. Verify motor function using GUI diagnostics and replace if necessary
3. Rear shaft does not turn	1. Rear shaft bearing blocks not aligned 2. Rear shaft is bent 3. Rear wheels binding against bearing blocks 4. Rear shaft noise	1. Re-align bearing blocks and carefully tighten 2. Replace shaft 3. Adjust one wheel 1/16" away from sleeve bearing by loosening set screws on wheel 4. Replace rear shaft if bent

Error Message - Table 6-6 continued

What you may observe	Potential problem	Action
4. Distance encoder sensor failure	1. Broken wire or loose connection at sensor or at the electronic enclosure	1. Option 1: Repair connection Option 2: Verify sensor function using GUI diagnostics and replace if necessary
5. Distance encoder sensor out of adjustment	1. Loose sensor or mounting hardware 2. Loose mounting hardware for the rear shaft	1. Tighten hardware and verify adjustment <i>See Adjusting the distance encoder for more information</i> 2. Tighten hardware and verify adjustment

Error Message - Table 6-7:

An error occurred during operation.

The Cord Kill Switch is not working properly. The Cord Kill Switch was activated.



NOTE:

Verify error source through GUI diagnostics.

What you may observe	Potential problem	Action
1. Power cord is obstructed		1. Make sure that power cord has free movement as it travels 2. Do not step on cord while machine is in operation
2. Cord kill switch malfunction	1. Broken wire or loose connection at switch or at the electronic enclosure 2. Cord kill switch failed 3. Cord kill switch is out of adjustment 4. Cord kill stud tension is incorrect	1. Repair connection 2. Verify switch function using GUI diagnostics and replace if necessary 3. Position switch mounting bracket so the switch is activated by the cord kill stud (1/32" to 1/16" from switch housing) 4. Adjust cord kill stud to 70 pounds of pulling force to activate the switch (compressed length of heavy spring is 3/4")

Error Message - Table 6-8:

An error occurred during operation.
The Buffer Brush is not working properly. The Buffer
Brush down sensor was not activated.



NOTE:

Verify error source through GUI diagnostics.

What you may observe	Potential problem	Action
1. Buffer brush lifting motor cycles until it actuates the up switch	1. Broken wire or loose connection at switch or at the electronic enclosure 2. Failed switch	1. Repair connection 2. Verify switch function using GUI diagnostics and replace if necessary
2. Buffer brush is up and did not lower	1. Loose cam 2. Broken wire or loose connection at motor or at the electronic enclosure 3. Buffer brush lifting motor failure	1. Tighten set screw on the "flat" of the motor shaft 2. Repair connection 3. Verify motor function using GUI diagnostics and replace if necessary

Error Message - Table 6-9:

An error occurred during operation.
The Buffer Brush is not working properly. The Buffer Brush up sensor did not activate.



NOTE:

Verify error source through GUI diagnostics.

What you may observe	Potential problem	Action
1. Buffer brush lifting motor cycles until it actuates the down switch	1. Broken wire or loose connection at switch or at the electronic enclosure 2. Failed switch	1. Repair connection 2. Verify switch function using GUI diagnostics and replace if necessary
2. Buffer brush is down and did not raise	1. Loose cam 2. Broken wire or loose connection at motor or at the electronic enclosure 3. Buffer brush lifting motor failure	1. Tighten set screw on the "flat" of the motor shaft 2. Repair connection 3. Verify motor function using GUI diagnostics and replace if necessary

Error Message - Table 6-10:

An error occurred during operation.

The Squeegee is not working properly. The Squeegee Up sensor did not activate.



NOTE:

Verify error source through GUI diagnostics.

What you may observe	Potential problem	Action
1. Squeegee motor cycles until it actuates the down switch	1. Broken wire or loose connection at switch or at the electronic enclosure 2. Failed switch	1. Repair connection 2. Verify switch function using GUI diagnostics and replace if necessary
2. Squeegee is down and did not raise	1. Loose cam 2. Broken wire or loose connection at motor or at the electronic enclosure 3. Squeegee lifting motor failure	1. Tighten set screw on the "flat" of the motor shaft 2. Repair connection 3. Verify motor function using GUI diagnostics and replace if necessary

Error Messages - Table 6-11:

An error occurred during operation.
The Duster cloth is not working properly. The
Duster cloth up sensor did not activate.



NOTE:

Verify error source through GUI diagnostics.

What you may observe	Potential problem	Action
<p>1. Duster cloth is down and did not raise</p>	<p>1. Duster cloth not attached properly to the waste core</p> <p>2. Duster cloth supply roll turns easily</p> <p>3. Duster cloth supply roll is not able to turn</p> <p>4. Broken wire or loose connection at switch, motor or at the electronic enclosure</p> <p>5. Failed switch</p> <p>6. Failed duster motor</p> <p>7. Plastic plug on end of duster cloth waste core is not properly engaged into drive hub.</p>	<p>1. Check attachment</p> <p>2. Tighten clutch torque bolt</p> <p><i>See Adjusting the duster clutch for more information</i></p> <p>3. Option 1: Loosen clutch torque bolt</p> <p><i>See Adjusting the duster clutch for more information</i></p> <p>Option 2: Replace friction pad(s)</p> <p>4. Repair connection</p> <p>5. Verify switch function using GUI diagnostics and replace if necessary</p> <p>6. Verify motor function using GUI diagnostics and replace if necessary</p> <p>7. Check that duster cloth is not restricting the plastic plug from full engagement with roll pin in drive hub. Also check staples are not loose between plug and core.</p>

Error Message - Table 6-12:

An error occurred during operation.

The End of Lane Sensor was not received when expected. Reset the lane length counter on the counters screen, then check the End of Lane Sensor.



NOTE:

The above message is generated when the machine forward travel stops and reverses before the end of the pin deck.



NOTE:

Verify error source through GUI diagnostics.

What you may observe	Potential problem	Action
1. LED on end of lane sensor is not lit	1. Improper Height	1. Adjust Height <i>See Adjusting the end-of-lane sensor for more information</i>
	2. Improper Sensitivity Adjustment	2. Adjust Sensitivity <i>See Adjusting the end-of-lane sensor for more information</i>
	3. Pin deck out of spec, defective pin spot, or missing lane plug	3. Option 1: Adjust or repair pin deck Option 2: Replace pin spot or missing lane plug
	4. Failed Sensor	4. Verify sensor function using GUI diagnostics and replace if necessary

Error Messages - Table 6-13:

Other error messages



NOTE:

Verify error source through GUI diagnostics.

These messages begin...	Potential problem	Action
The lane machine is not ready for operation...		
An error occurred during the pattern parameter download	1. Changes to the existing pattern parameters did not download correctly to the machine	1. Exit the screen and try again
Invalid pattern parameters were sent to the controller or the pattern parameter crc is bad	1. The lane machine cannot operate with the current pattern parameters	1. Download the pattern again 2. Contact the CRC or your Brunswick installer for the lane machine
Flash packet write error	1. The controller could not write the crc data to the flash memory	1. Turn off the power, restore the power and try running again.
An error occurred during the pattern download	1. The desired lane conditioning pattern did not download correctly to the lane machine.	1. Turn off the power, restore the power and download the pattern again.
Power lost	1. Machine is unplugged, the power switch on the enclosure is off, or the emergency stop switch has been depressed. 2. Defective machine control pcb.	1. Check that the power cord is plugged into a working outlet and that all power switches are turned on. 2. Contact the CRC or your Brunswick installer of the lane machine.
The cleaner pressure is not set properly. The cleaner pressure is low.	1. The pressure for the cleaner is set below 15 psi. 2. Dirty bowl filter in the cleaner system. 3. Tubing not pressed into the fittings completely or not trimmed at a 90 degree angle - allowing air into the system.	1. Follow the adjustment; Cleaner Pinch Valve Adjustment 2. Remove bowl filter, inspect, clean or replace as required. <i>Note: debris accumulates on the inside of this screen filter and may not be viewable from the outside.</i> 3. Check tubing connections - reseal in the fitting or re-trim as needed.
The controller board did not respond within the required time period.	1. There is a communication problem with the controller pcb 2. The operator did not respond to a machine command within the allowable time frame.	1. Press "ok" then re-enter the screen and try again 2. Press "ok" then re-enter the screen and try again

Warning Messages

Warning messages appear when certain parameters are incorrect for proper operation. Maintenance messages are warning messages generated by counters that track when wearable parts have reached their usage limits covered in the next section.

The images in Figure 6-17 are examples of warning messages the GUI may display.

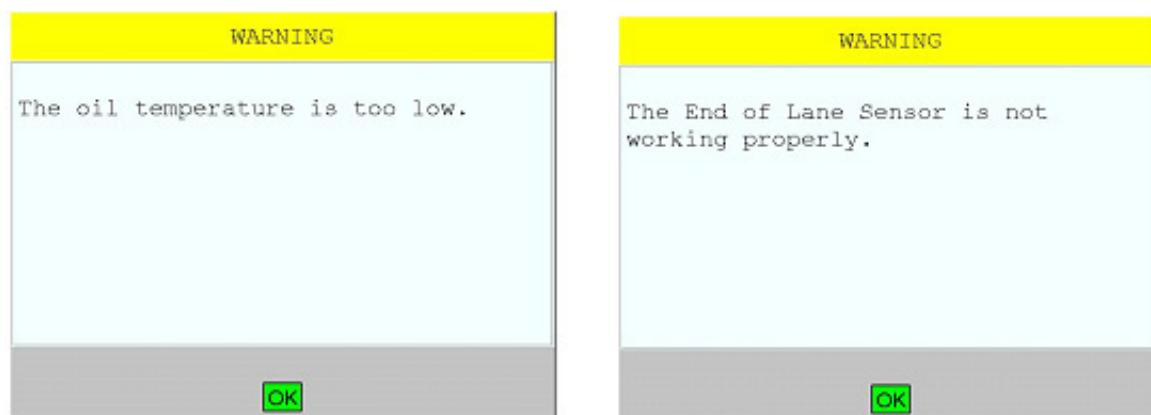

Figure 6-17. GUI Warning Messages

Table 6-14 provides a list of warning messages with potential remedies. If you're unable to resolve a problem, please contact your authorized Distributor or the Brunswick Customer Response Center (CRC) in the United States at 1-800-YES-BOWL, or internationally at 231-725-4966. For non emergency support, e-mail crsupport@brunbowl.com



NOTE:

Maintenance logs can be backed up to a USB flash drive as explained earlier in Section 4, "Backing Up and Importing Data". These logs may contain information that is helpful to the Brunswick Customer Response Center when troubleshooting issues. They can explain how to attach backup files to an e-mail or ship the USB flash drive with your center maintenance logs. The maintenance logs, counters and critical center data cannot be imported back to your GUI.

Warning Messages - Table 6-14.



NOTE:

Verify warning source through GUI diagnostics.

These messages begin...	Potential problem	Action
<p>The lane machine is not ready for operation...</p>		
<p>The oil level is low. Add more oil to the tank.</p>	<ol style="list-style-type: none"> 1. Conditioner Level 2. Level sensor is unplugged at the tank or electronic enclosure 3. Level sensor has failed 	<ol style="list-style-type: none"> 1. Add conditioner to the conditioner supply tank 1" from the top 2. Reconnect the cable 3. Verify sensor function using GUI diagnostics and replace if necessary
<p>The cleaner level is low. Add more cleaner to the tank</p>	<ol style="list-style-type: none"> 1. Cleaner level is low 2. Level sensor is unplugged at the tank or electronic enclosure 3. Level sensor has failed 	<ol style="list-style-type: none"> 1. Add cleaner to the cleaner supply tank 1" from the top 2. Reconnect the cable 3. Verify sensor function using GUI diagnostics and replace if necessary
<p>The oil temperature is too low</p> <p><i>(Only occurs when the "Temperature cycle" function is turned "ON")</i></p>	<ol style="list-style-type: none"> 1. Conditioning system has not reached the target temperature. 2. Temperature sensor or the heating element is unplugged. 3. Temperature sensor or heating element has failed 	<ol style="list-style-type: none"> 1. Press "OK" to bypass message and continue heating or allow system to reach the target temperature 2. Reconnect the cable 3. Verify sensor or heating element using GUI diagnostics and replace if necessary

Warning Messages - Table 6-14 continued

These messages begin...	Potential problem	Action
<p>The lane machine is not ready for operation...</p>		
<p>The oil temperature is too high</p> <p>The end of lane sensor was activated too early. The end of lane sensor may be faulty.</p>	<p>1. Conditioning system has exceeded the target temperature</p> <p>2. Heater is always on</p> <p>1. End of lane sensor is out of adjustment</p> <p>2. End of lane sensor is unplugged</p>	<p>1. Go to the System settings and turn "OFF" the Temperature Cycle</p> <p>2. Option 1: Check voltage going to heater</p> <p>Option 2: Check LED function on motor control board</p> <p>1. Option 1: Check height and sensitivity adjustments <i>See Adjusting the end-of-lane sensor for more information</i></p> <p>Option 2: Check for excess gap between lane panels and pindeck, missing plugs, or gutters that are too high (raising the front of machine). Have qualified maintenance person address lane or gutter repairs.</p> <p>2. Reconnect cable</p>

Maintenance Messages

Maintenance messages, as detailed in Table 6-15, tell you when a consumable part has reached its usage limit. We recommend you perform the necessary maintenance as soon as the message occurs. You can, however, override the message if necessary. For example: until you have completed all lanes.

To override a maintenance message, press “OK.” The message continues to display each time the machine is prepared for operation, until the maintenance is completed and the counter is reset.

Once you have checked or replaced the part, reset the counter in the “Counters” screen of the Maintenance menu. Navigate to the expired counter reset and press “OK.” Refer to Figure 6-18.

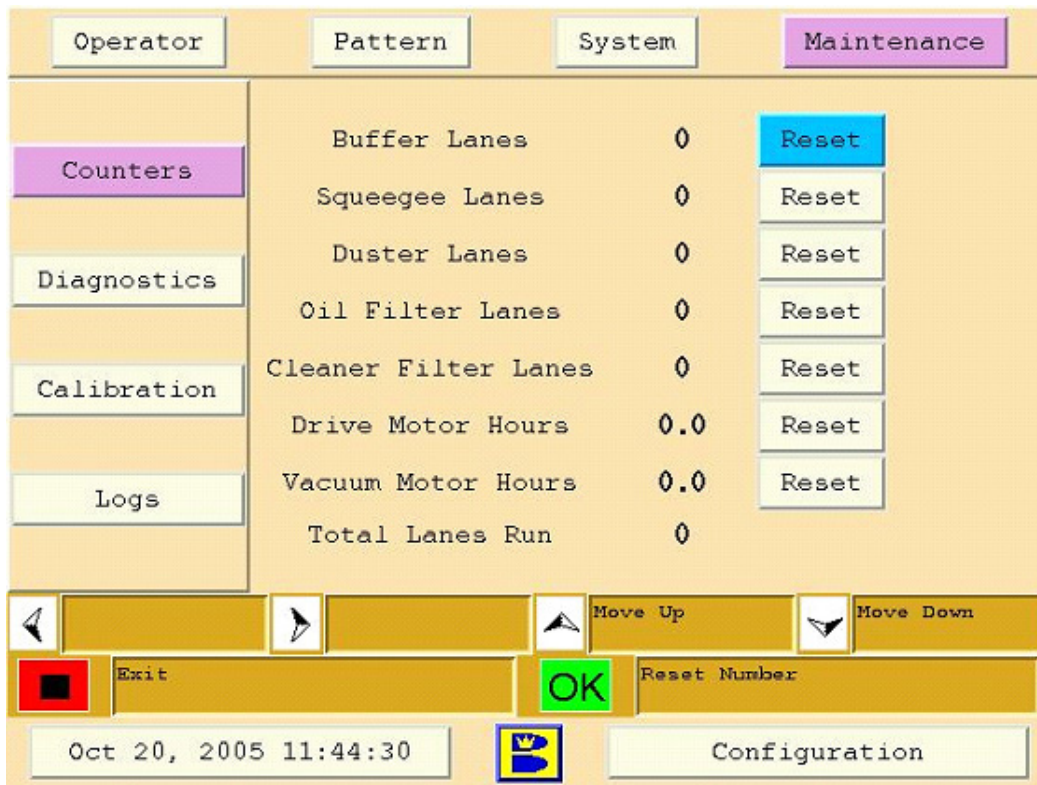

Figure 6-18. Maintenance Messages

Quick-list of Maintenance Counters

Buffer Lanes	29,200 lanes
Squeegee Lanes	14,600 lanes
Duster Lanes	700 lanes
Oil Filter Lanes (refers to Spin-on filter)	29,200 lanes
Cleaner Filters Lanes	29,200 lanes
Drive Motor Hours	5000 hours
Vacuum Motor Hours	500 hours

Maintenance Messages - Table 6-15.

<p>These messages begin...</p> <p>A hardware counter has expired...</p>	<p>Action</p>
<p>Duster cloth needs to be replaced</p>	<p>Replace the duster cloth, select reset and press "OK"</p> <p>See <i>Replacing the duster cloth</i> for more information.</p>
<p>The buffer brush needs to be replaced</p>	<p>Replace the buffer brush, select reset and press "OK"</p> <p>See <i>Replacing the buffer brush</i> for more information</p>
<p>The squeegee blade needs to be replaced</p>	<p>Replace the squeegee blade, select reset and press "OK"</p> <p>See <i>Replacing the squeegee blade</i> for more information</p>
<p>The cleaner screen filter needs to be replaced or cleaned</p>	<p>Clean or replace the cleaner screen filter, select reset and press "OK"</p> <p>See <i>Replacing/cleaning the conditioner/in-line strainer</i> for more information</p>
<p>The conditioner spin-on filter needs to be replaced</p>	<p>Replace the conditioner spin-on, select reset and press "OK"</p> <p>See <i>Replacing the spin-on conditioner filter</i> for more information</p>
<p>The traction drive motor needs to be replaced</p>	<p>Service and replace the traction drive motor select reset and press "OK"</p>
<p>The vacuum motor assembly needs to be replaced</p>	<p>Service and replace the vacuum motor assembly select reset and press "OK"</p>

Mechanical Failures

Tables 6-16 through 6-21 provide a list of possible mechanical failures and the steps to correct them. If you need assistance, please contact your authorized Distributor or the Brunswick Customer Response Center (CRC) in the United States at 1-800-YES-BOWL, or internationally at 231-725-4966. For non emergency support, e-mail crcsupport@brunbowl.com

List Of Mechanical Failure Categories

Duster Cloth Assembly - Table 6-16

Cleaning System - Table 6-17

Conditioning Appearance & Application - Table 6-18

Traction Drive System - Table 6-19

Electrical System - Table 6-20

GUI - Table 6-21

Duster Cloth Assembly - Table 6-16



NOTE:

Verify failure source through GUI diagnostics.

Problem	Cause	Solution
Machine leaving lines of dust on the lane.	<ol style="list-style-type: none"> 1. Duster cloth is too wet 2. Duster clutch is too tight, cloth 	<ol style="list-style-type: none"> 1. Option 1: Verify correct cleaner pressure. Option 2: Adjust spray nozzles away from duster cloth. 2. Loosen clutch adjustment <i>See Adjusting the duster cloth for more information</i>
Duster cloth is not dusting entire lane.	<ol style="list-style-type: none"> 1. Duster contact roller is not lowering completely 2. Duster contact roller has flat spots or depressions 	<ol style="list-style-type: none"> 1. Option 1: Check for binding in roller movement. Option 2: Check for uneven winding of cloth. 2. Option 1: Replace contact roller cushion tube. Option 2: Check lane for topography problems.
Duster assembly chatters on back of lane	<ol style="list-style-type: none"> 1. Contact roller cushion has a flat spot 	<ol style="list-style-type: none"> 1. Replace contact roller cushion tube
Duster cloth is dragging on lane during return run	<ol style="list-style-type: none"> 1. Clutch is adjusted too loose 2. Loose hub on duster cloth motor shaft 3. Hub on take up core is loose and slipping 4. Duster cloth motor failure 	<ol style="list-style-type: none"> 1. Tighten clutch adjustment per manual <i>See Adjusting the duster cloth for more information</i> 2. Tighten set screw in hub 3. Repair or replace hub on cardboard take up core 4. Verify motor function using GUI diagnostics and replace if necessary

Cleaning System - Table 6-17



NOTE:

Verify failure source through GUI diagnostics.

Problem	Cause	Solution
Lane is not getting clean (Cleaner spray system problems)	<ol style="list-style-type: none"> 1. Obstruction in cleaner supply tank 2. Clogged cleaner screen filter 3. Cleaner pump not running 4. Blockage in one or more cleaner spray nozzles 5. Cleaner supply tank empty 6. Low cleaner spray system pressure 7. Cleaner spray nozzle(s) not properly adjusted 8. Poor water quality 9. Improper cleaner or mix ratio 	<ol style="list-style-type: none"> 1. Check inside supply tank for foreign matter 2. Remove cleaner screen filter, clean or replace as needed 3. Option 1: Verify operation using maintenance screen Option 2: Check for correct voltage at cleaner pump plug Option 3: Check for bad fuse on motor controller PCB Option 4: Check for bad wire or plug connection Option 5: Replace cleaner pump 4. Option 1: Clean with hot water or replace check valve filter; Option 2: Clean with hot water or replace spray tip 5. Adjust low fluid sensor by turning to allow for clean vertical drop, or replace 6. Option 1: Adjust max pressure to 22 psi Option 2: Adjust min pressure to 18 psi Option 3: Verify cleaner screen filter is not clogged Option 4: Replace cleaner bypass Valve Option 5: Replace cleaner pump 7. Option 1: Perform cleaner spray test in maintenance menu test screen Option 2: Adjust cleaner spray nozzles so spray in a straight line across the lane with even overlap. Align ball joint if necessary (call CRC). 8. Use a charcoal filter to filter impurities when mixing cleaner 9. Try using a higher mix concentration of cleaner (4:1) or call CRC for advice on the proper cleaner for your type of conditioner.

Cleaning System - Table 6-17 continued

Problem	Cause	Solution
Lane is not getting clean (Squeegee head assembly problems)	1. Worn absorbent wiper	1. Turn, flip, or replace based on condition
	2. Improperly adjusted squeegee head assembly	2. Use adjusting template to perform adjustment and check squeegee blade deflection on the lane. <i>See Adjusting Squeegee for more information</i>
	3. Worn squeegee blade	3. Turn or replace based on condition
	4. Poor vacuum seal	4. Option 1: Adjust vacuum mounting bracket plate Option 2: Replace vacuum seal
	5. Poor performance of vacuum motor	5. Repair or replace vacuum motor
	6. Waste recovery tank is over full	6. Remove the waste tank from the machine and dispose of the used lane machine waste properly. Do NOT dump recovery tank in a septic tank or sanitary sewer system. Follow your local environmental regulations for the best method of disposal.
	7. Dirty cleaner drips on return	7. Option 1: Vacuum hose cuffs are not tight around the in-take pipe of the squeegee head assembly or on the waste recovery tank Option 2: Vacuum exhaust diffuser foam is not in proper position or needs to be cleaned or replaced. Option 3: Squeegee blade is not clamped straight

Conditioning Appearance & Application - Table 6-18



NOTE:

Verify failure source through GUI diagnostics.

Problem	Cause	Solution
One or more conditioner injectors are not firing	<ol style="list-style-type: none"> 1. Unplugged conditioner injector cable 2. Defective conditioner injector, wire, connection, or PCB 	<ol style="list-style-type: none"> 1. Option 1: Reconnect plug to conditioner injector Option 2: Reconnect plug at electronic enclosure 2. Contact CRC for troubleshooting support.
Injector marks not blended on lane surface	<ol style="list-style-type: none"> 1. Buffer brush out of adjustment 2. Dispersion roller out of adjustment 3. Buffer brush not rotating 4. Defective buffer brush 5. Buffer drive motor not operating 	<ol style="list-style-type: none"> 1. Refer to Buffer Brush Adjustment for more information 2. Refer to Dispersion roller adjustment for more information 3. Option 1: Tighten buffer brush bolt Option 2: Verify and adjust buffer belt tension 4. Verify buffer brush lane counter and replace if necessary 5. Option 1: Verify fuse condition, and replace is necessary Option 2: Verify motor function using GUI diagnostics and replace if necessary
Tape readings different than programmed units	<ol style="list-style-type: none"> 1. Wrong conditioner selected in the <i>System Conditioner</i> screen 2. Conditioning system not holding pressure 3. Lane surface is not getting cleaned properly 4. Duster contact roller dragging in pattern 5. Buffer brush worn or out of adjustment 6. Lane monitor not working properly 	<ol style="list-style-type: none"> 1. Select the correct lane conditioner – if not listed contact Brunswick CRC 2. Verify pressure through GUI diagnostics, if machine is not holding pressure contact the Brunswick CRC 3. Check cleaning system adjustments <i>Refer to Cleaning System Adjustment for more information</i> 4. Adjust duster clutch 5. <i>Refer to Buffer Brush Adjustment for more information</i> 6. Contact the Brunswick CRC

Traction Drive System - Table 6-19



NOTE:

Verify failure source through GUI diagnostics.

Problem	Cause	Solution
Noise coming from the drive system	<ol style="list-style-type: none"> 1. The traction motor chain is not aligned properly 2. Traction motor chain is too loose or too tight 3. Too much traction drive shaft movement from side to side 4. Bent traction drive shaft 	<ol style="list-style-type: none"> 1. Adjust sprockets until the chain is aligned correctly 2. Adjust traction drive motor until there is a 1/2" movement in the chain 3. Adjust traction drive wheels 1/16" from bearing blocks 4. Verify shaft is bent, replace if necessary
Travel Speed is incorrect or inconsistent	<ol style="list-style-type: none"> 1. Wrong speed selected in the <i>Pattern, Design, Forward Speed</i> option 2. Electrical issue (low voltage) 	<ol style="list-style-type: none"> 1. Make sure the desired <i>Forward Speed</i> is selected 2. Contact Brunswick CRC or contact your certified A22 technician
Not traveling down lane	<ol style="list-style-type: none"> 1. Traction wheels not in contact with lane 2. Traction drive motor is not operating 	<ol style="list-style-type: none"> 1. Option 1: Verify squeegee head assembly adjustment <i>Refer to Squeegee Head Assembly Adjustment for more information</i> Option 2: Verify guide rollers, adjust guide roller spacing if necessary Option 3: Verify proper gutter height, repair if necessary 2. Option 1: Verify fuse condition, and replace if necessary Option 2: Verify motor function using GUI diagnostics and replace if necessary

Electrical System - Table 6-20



WARNING!

Always unplug power cord from the machine before servicing or lifting machine into transport position.

Problem	Cause	Solution
No power to power to electronics enclosure	<ol style="list-style-type: none"> 1. <i>Power cord</i> is not plugged in 2. Main switch on the electronic enclosure is turned "OFF" 3. Emergency shut-off switch button is depressed 	<ol style="list-style-type: none"> 1. Connect the power cord to the machine and power receptacle 2. Turn on main switch (switch should illuminate when "ON") 3. Twist the Emergency shut-off switch to disengage
Trips in-line breakers	<ol style="list-style-type: none"> 1. Bad wire connection in power supplied to machine 2. Incorrect wiring at outlet 3. Short in electrical system 4. Waste fluid overflow into vacuum motor 	<ol style="list-style-type: none"> 1. Check all connections in the power cord and power cable assembly to electronic enclosure 2. Check for incorrect polarity at power outlets where machine plugs in, and repair if necessary 3. Contact the Brunswick CRC 4. Clean waste fluid from vacuum motor and empty waste recovery tank at proper intervals.
Blown fuse	<ol style="list-style-type: none"> 1. Bad or pinched wire or cable assembly 2. Wrong fuse size 3. Improper adjustment of component 	<ol style="list-style-type: none"> 1. Repair or replace cable assembly 2. Replace with correct size fuse <i>See Appendix for electrical drawings</i> 3. Adjust chain, belt, or check for binding of component(s) related to the fuse

GUI - Table 6-21

Problem	Cause	Solution
No power to GUI	<ol style="list-style-type: none"> 1. Power is disconnected at the GUI or the electronic enclosure 2. Emergency shut-off switch is depressed 3. Power cord is not plugged in 4. Main switch on the electronics enclosure is turned off 	<ol style="list-style-type: none"> 1. Reconnect cable 2. Twist the Emergency shut-off switch to disengage. 3. Check the 125' power cord is properly connected at both ends. 4. Turn on main switch on electronics enclosure.
GUI reboots when changing outlets	<ol style="list-style-type: none"> 1. Uninterruptible Power Supply (UPS) is not charged (LED does not blink when turned off) 2. Failed UPS Board 	<ol style="list-style-type: none"> 1. Supply power to GUI for 4 hours 2. Contact Brunswick CRC

Section 7: Pattern Design Theory

Pattern Development

The Authority22 pattern design theory is based on Brunswick's history of understanding the relationship between bowling balls, lane conditioners, and lane surfaces. Coupled with the new Accu-ject™ innovation it is now possible for centers to truly customize their lane conditioner patterns to better benefit the bowlers and their bowling balls.

Accu-ject innovation allows accurate placement of conditioner nearly every inch of the pattern so you can design and adjust specific areas of the conditioner patterns without affecting the entire pattern. This makes the process of setting up and adjusting patterns much quicker than existing machines. You simply select the zone that you wish to design or adjust and set the oil level to the desired volume and shape.

The Authority22's forward only conditioner application is an enormous benefit for creating not just good ball reaction, but great ball reaction. Since the conditioner is applied on the forward travel, the pattern transition down the lane will always be smooth and allows the ball to store more energy for the back end of the lane. Unlike other machines that rely on reverse conditioner application to create the lengthwise taper of a pattern. Reverse conditioner creates inconsistencies, within the pattern, that causes the bowling ball to release its energy inconsistently as it travels down the lane, storing less for the back ends. This action is responsible for making patterns less predictable and bowler adjustments more difficult. Follow these important steps to develop proper lane maintenance practices and a great conditioner pattern for you center.

1. Identify your bowling environment.
The bowling environment holds many variables that can affect your lane surface. The surface type, age, and name of the surface or finish, give it specific ball reaction characteristics. The condition of the kickbacks and kickback plates and the solidness of the pin deck and flat gutters can affect pin movement.
2. Recognize your geographic region.
The region of the world in which you live can dictate how you need to store your equipment and supplies. To eliminate issues with varying temperatures as the seasons change, store your Authority22, conditioners, and cleaners in a room that has temperature control. Conditioners can become thicker and cleaners can crystallize when they become cold. This can increase the preparation time to set up the machine and possibly affect the characteristics of the products. The amount of dirt your center produces can affect lane pattern.

3. Frequency of general maintenance.
All centers should perform general maintenance to the bowling area on a daily basis. Though, we know that is not always true, you should recognize how dirty your environment is and structure a maintenance program accordingly. Dust and dirt can affect the performance of a conditioner pattern making it appear that it is breaking down faster. Dust migrates with the air flow and dirt is transferred by the bowlers and the balls. Keeping the floors and carpets clean, the approaches and gutters clean, along with pinsetter maintenance, will help the performance of the bowlers and the conditioner pattern.
4. Your bowlers.
Bowlers are a product of their environment. How they bowl and what they throw is based on what they bowl on. Bowlers vary between recreational to competitive bowlers and everywhere in between. Setting up appropriate patterns for various customers can minimize pinsetter issues and allow you to use your supplies more efficiently.
5. Choose the correct supplies.
This is the most important step in consistent lane conditions. It is also the most forgotten. The correct choices in supplies can make the difference between happy or unhappy customers. Making the proper choice is sometimes not so easy. A conditioner should provide good durability, have minimal movement down the lane (carry down), and clean easily. Always use a “bowling” specific lane cleaner. Cleaners should be designed to remove the type of conditioner you are using. Not all cleaners will clean all conditioners. Synthetic conditioners require cleaners with d-limonene while standard conditioners can use a standard bowling lane cleaner. If the lanes are not clean, then the pattern will not be consistent.

Understanding a Conditioner Pattern

The proper design of the conditioner pattern is critical to making your customers happy. Here are some tips to help you understand key components for developing patterns.

1. Pattern length.
Typical pattern lengths used today range between 36 to 42 feet. Although we do see pattern lengths both shorter and longer for tournaments, the distance should be determined by the back end hook characteristic of your lane surface.
2. Lengthwise taper.

The lengthwise distribution of the conditioner pattern influences the quality of ball reaction. The greater the taper, from the beginning to the end of the pattern, results in more smooth and predictable ball reaction. The lengthwise ratio usually ranges from 3:1 to 5:1 and is measured by the “units of oil” in the front (heads) of the pattern divided by the units of oil measured at the end of the pattern (i.e. 75 unit and 15 units equals a 5:1 ratio). The proper taper will help store the ball energy, making the pins come alive and improving the strike percentage. Refer to Figure 7-1.

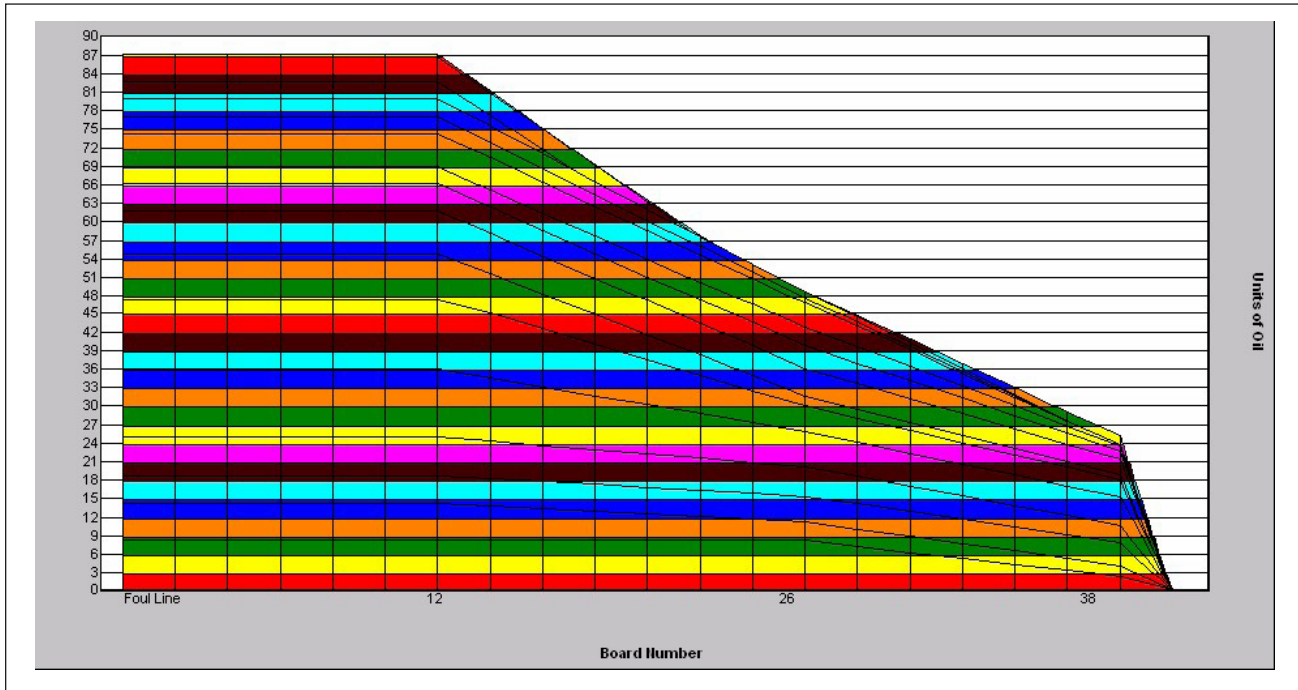

Figure 7-1. Lengthwise Taper

3. Crosswise shape.

The crosswise shape of the pattern influences the scoring difficulty level. It is measured by the amount conditioner on the center boards divided by the amount on the outside boards. Ratios can range from 5:1 to 10:1 for recreational league patterns and 3:1 or less for sport patterns. The higher the ratio, the higher the scores typically are. The crosswise shape is based on lane surface and bowler characteristics. Refer to Figure 7-2.

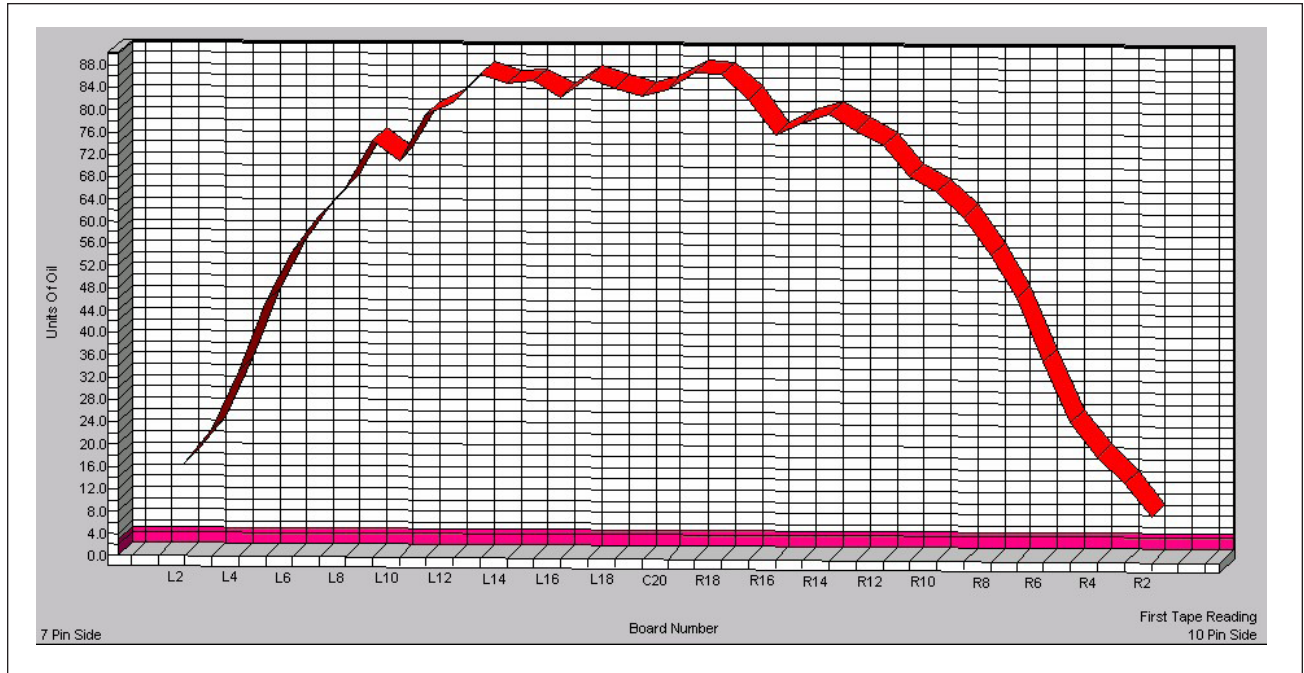

Figure 7-2. Crosswise Shape

Design a Conditioner Pattern

Pattern design with the Authority22 has become a lot easier. We have given you the control over the patterns you deserve in the language you are accustomed to... units of oil.

1. Zone configuration

The zone configuration allows you to design patterns with a minimum of one zone to a maximum of eight zones. Zone lengths can range from 3 feet to 57 feet. Recreational patterns can vary from 3 zones to 5 zones with zone lengths from 8 feet to 12 feet. The last zone in the pattern should always be a buff zone to help optimize the lengthwise taper of the pattern. Adjust the cleaner transition so the volume of cleaner reduces at least two feet into the last zone. Sport and competitive patterns utilize 5 to 8 zones with zone lengths ranging from 5 feet to 10 feet. Again, the last zone should be a buff zone. The cleaner transition should be adjusted to two feet past the pattern ending distance to ensure that the pattern is properly cleaned. Refer to Figure 7-3.

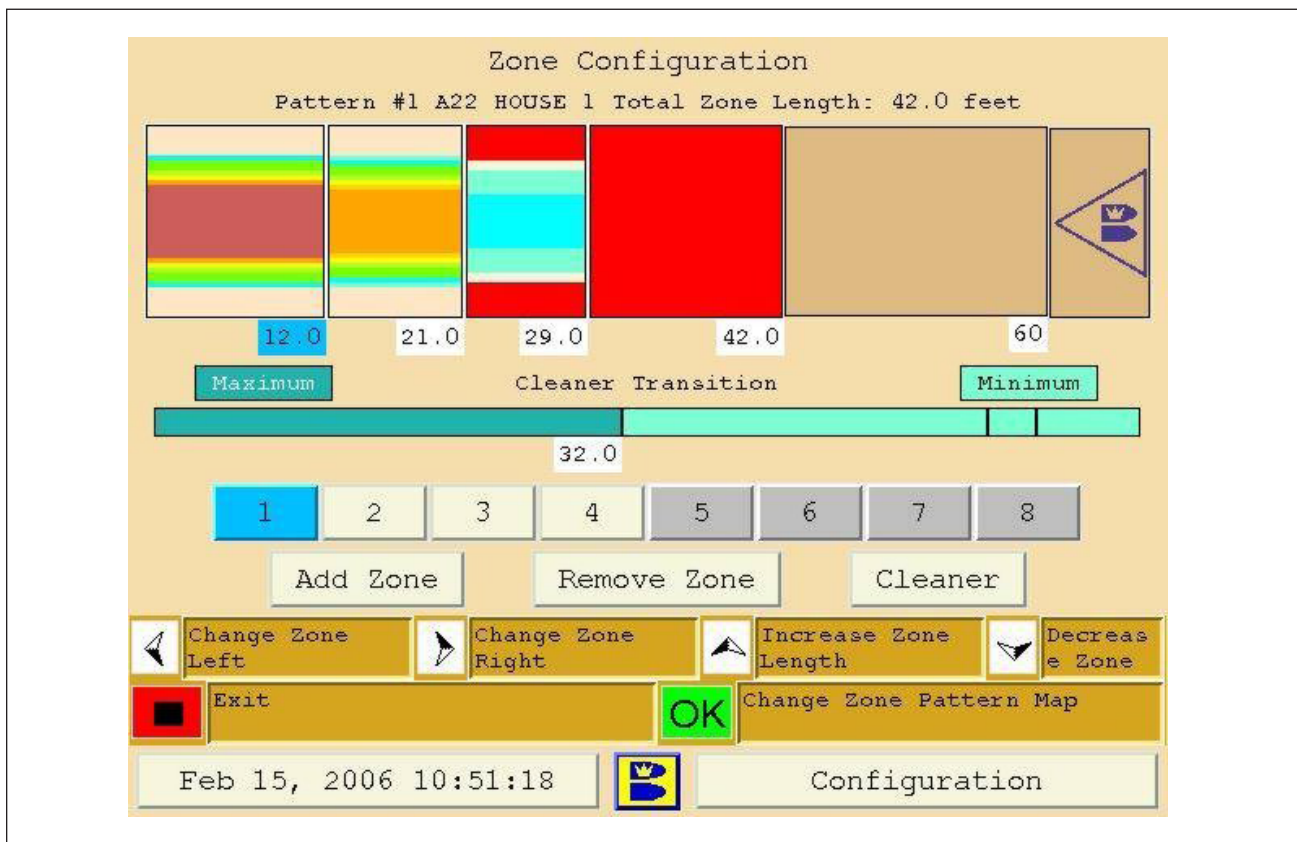

Figure 7-3. Zone Configuration

2. Oil levels

The oil levels screen allows you to create the shape and levels of the conditioner pattern in units of oil. Minimum and maximum levels range from 0 to 100 units. To create the proper lengthwise taper of a pattern, oil levels, from zone to zone, should decrease between 15% and 30%. This is the same for sport and recreational patterns. The percent decrease from zone to zone depends on the starting oil level in the first zone. If the first zone conditioner level is lower (60 units or less) the percentage decrease in the following zones will be smaller and if the first zone conditioner level is higher (above 60 units), the percentage of decrease is higher. The last zone or buff zone should have 1 to 3 units set in the oil level screen on at least one board. This allows the machine to buff the remaining zone of the pattern, in both directions, without injecting conditioner and enhance the lengthwise taper. Set all boards for zero (0) and the machine will buff the last zone in the forward direction of travel only. This increases the lengthwise taper even more. Refer to Figure 7-4.

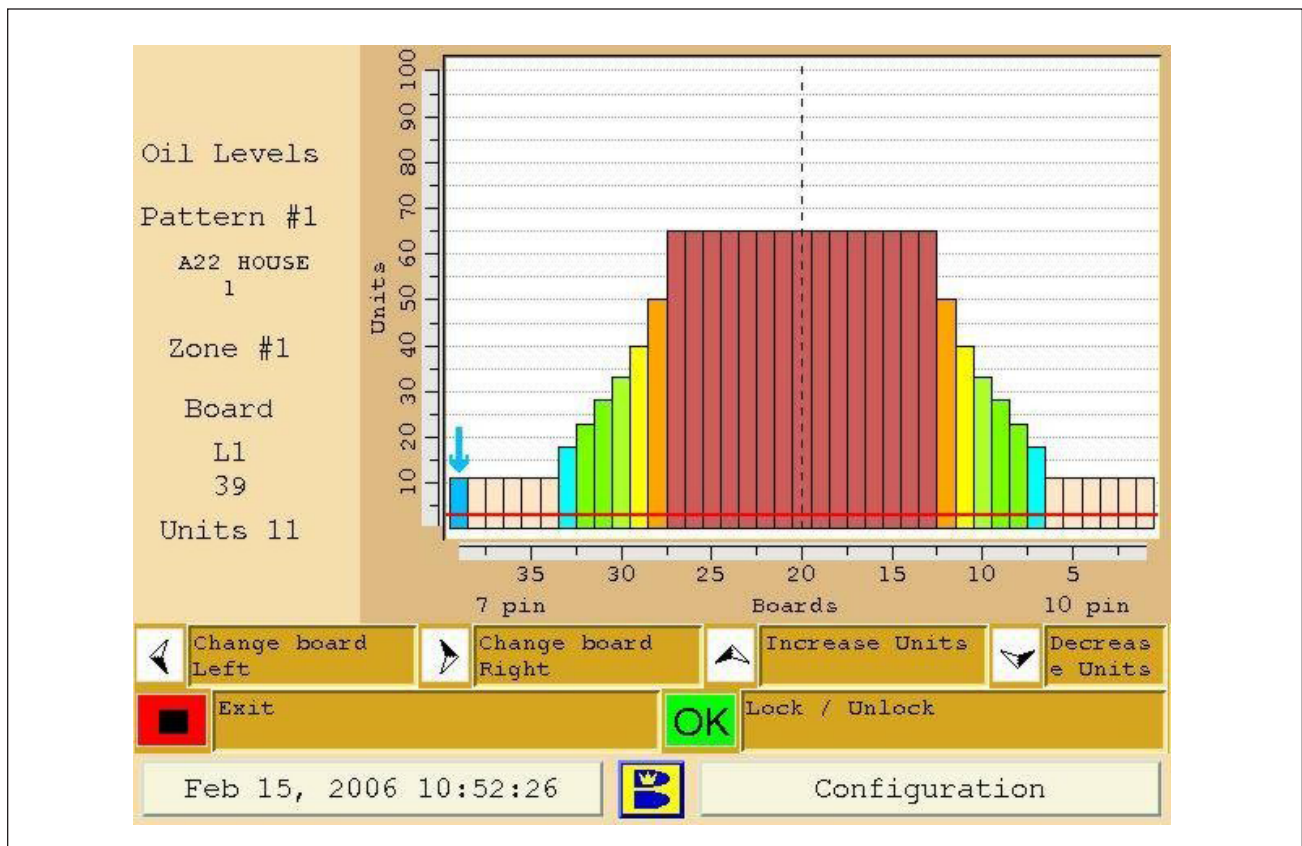

Figure 7-4. Oil Levels

Verifying the Conditioner Pattern

Verification of the conditioner pattern is a step used to qualify the pattern you are using. It allows you to see that the Authority22 is consistently producing a conditioner pattern based on what is programmed in the Pattern Design screens. It also allows you to identify wear components such as, the absorbent wiper, squeegee, or buffer brush. All of which can have an effect on the units of oil and the performance of a pattern as they have exceeded their life. To verify the conditioner pattern follow these steps.

1. Verify that the machine is cleaning properly before performing the verification process.
2. Select the zone or zones you wish to verify.
3. After running a few lanes, take a tape sample of the conditioner pattern, one foot before the end of that zone (i.e. zone #2 ends at 15 feet, tape distance is 14 feet).
4. Read the tape using the Brunswick Computer Lane Monitor.
5. Compare the lane monitor readings to the programmed units of oil in the GUI.

Adjusting the Conditioner Pattern

The Authority22 allows you to make adjustments to specific area of the conditioner pattern without having to make unnecessary adjustments to the rest of the pattern. Adjustments to the conditioner pattern should be made based on ball reaction. The ball reaction should be observed when the pattern is fresh and as it transitions as lineage increases. If the pattern transition is not as desired, refer to the follow procedure for making adjustments.

1. Identify the area of the pattern that is not performing properly.
2. Go to the pattern design screen and view the Zone Configuration and Oil Levels screens.
3. Select the zone that corresponds with the area of the lane that needs adjustments.
4. Make adjustments to the zone length or to the oil levels to change the pattern transition.
5. Download the pattern.
6. If the pattern adjustments are successful, go to the Pattern Data screen and save the pattern data to a backup file folder.

Authority22 Factory Preset Patterns

The Authority22 comes complete with 10 factory, starting patterns to accommodate the ever changing bowling environment to meet your customer's needs. The patterns range from standard recreational patterns to USBC compliant Sport Bowling patterns.

Pattern 1: A22 House 1

This pattern has a slight blend and a good lengthwise taper that produces high scores for the average bowler. It is also good for lane surfaces that have a less aggressive reaction characteristic.

Pattern 2: A22 House 2

A higher volume and more blended pattern designed for more aggressive reacting lane surfaces. This pattern is a great starting point for a majority of bowling centers with bowlers of all styles and skill levels.

Pattern 3: Ladies and Seniors

A pattern designed for the active women and senior bowlers in your center. This is a lower volume pattern that will produce less conditioner transition and reduce back end calls.

Pattern 4: Open Play

As the name says, this pattern is designed with open bowlers and house balls in mind. The low volume and simple structure of the pattern is designed to make open play life easier.

Pattern 5: Competitive 1

For bowlers that like a little more challenge than they get with typical house pattern. This pattern is great for those who are ready to take their game to the next level. It offers a smooth crosswise and lengthwise transition.

Pattern 6: Competitive 2

Otherwise known as “strips” or “stripes”, it defines two areas of the lane to play – deep inside or way outside. For bowlers who are not ready, it can be very difficult. Definitely, one of the most entertaining.

Pattern 7: Sport 3:1

Based on USBC specifications for Sport Bowling, this pattern offers a higher volume, good lengthwise taper and the shape that is within the 3:1 ratio for older lane surfaces.

Pattern 8: Sport 2.5:1

The “middle of the road” sport pattern that complies with USBC specifications for the age range of surfaces it is designed for. This pattern, like pattern 7, provides a good lengthwise taper to allow the ball to make it down the lane without interference from the lane surface.

Pattern 9: Sport 2:1

A very smooth “crown” pattern that creates no defined area of the lane to play. It is designed for the bowlers to play where they feel comfortable and is influenced more by the lane surface.

Pattern 10: Sport Flat version 2

Designed to enhance lane surface characteristics, this pattern has no crosswise shape to define a specific area of the lane to play. The pattern has a strong lengthwise taper that promotes very good ball reaction and gives the impression that it is easier than it really is.

2. Pattern - House 2

Pattern Information

Date	
Pattern Type	Recreational
Pattern Difficulty	Low
Pattern Designer	Brunswick

Surface Information

Surface Type	
Surface Brand	
Age	

Pattern Parameters

Pattern Number	2
Pattern Name	A22 HOUSE 2
Mode	Clean & Oil
Forward Speed	Quick Clean
Start Cleaner Spray	0
Start Squeegee	0
Start Oiling	12
Split Pattern	No

Notes

Supplies Information

Lane Cleaner	
Cleaner Mixture Ratio	: 1
Cleaner Transition Distance	41
Lane Conditioner	

Zone	1	2	3	4	5	6	7	8
Zone End Distance	7	14	22	30	39			

Zone Ratio	L	4.4 : 1	6.3 : 1	7.5 : 1	8.7 : 1	### : 1	### : 1	### : 1	### : 1
	R	4.4 : 1	6.3 : 1	7.5 : 1	8.7 : 1	### : 1	### : 1	### : 1	### : 1

ZONE	7 Pin Side							10 Pin Side																																				
	L1	L2	L3	L4	L5	L6	L7	L8	L9	L10	L11	L12	L13	L14	L15	L16	L17	L18	L19	C20	R19	R18	R17	R16	R15	R14	R13	R12	R11	R10	R9	R8	R7	R6	R5	R4	R3	R2	R1					
1	14	14	14	14	14	16	20	33	50	65	70	70	70	70	70	70	70	70	70	70	70	70	69	65	50	33	20	16	14	14	14	14	14	14	14	14	14	14	14					
2	8	8	8	8	8	11	24	37	50	54	55	55	55	55	55	55	55	55	55	55	55	54	50	37	24	11	8	8	8	8	8	8	8	8	8	8	8	8	8	8				
3	6	6	6	6	6	6	10	25	39	44	45	45	45	45	45	45	45	45	45	45	45	44	39	25	10	6	6	6	6	6	6	6	6	6	6	6	6	6	6	6	6			
4	4	4	4	4	4	4	6	18	29	34	35	35	35	35	35	35	35	35	35	35	35	34	29	18	6	4	4	4	4	4	4	4	4	4	4	4	4	4	4	4	4			
5	0	0	0	0	0	0	0	0	0	0	0	0	0	0	0	0	0	0	0	0	0	0	0	0	0	0	0	0	0	0	0	0	0	0	0	0	0	0	0	0	0			
6																																												
7																																												
8																																												

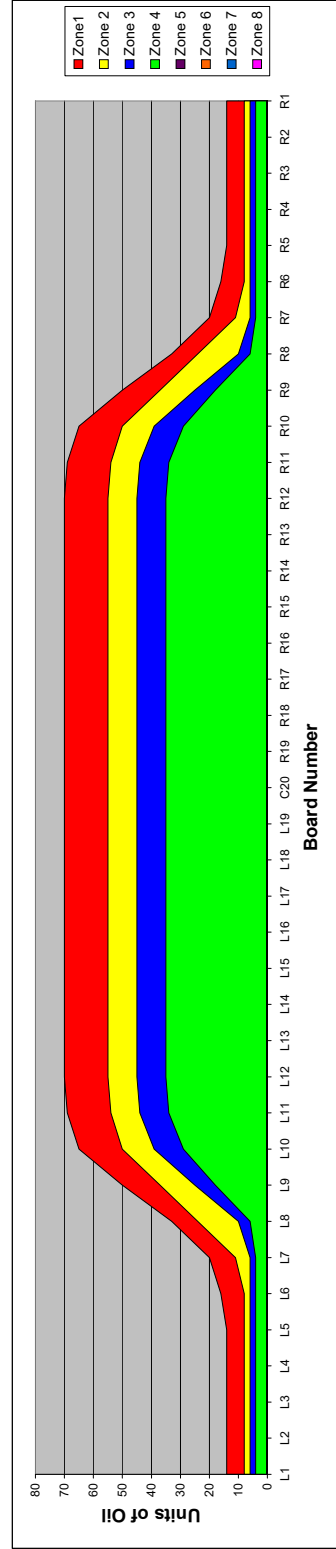

6. Pattern - Competitive 2 - Strips

Pattern Information

Date	
Pattern Type	Competitive
Pattern Difficulty	Medium
Pattern Designer	Brunswick

Surface Information

Surface Type	
Surface Brand	
Age	

Pattern Parameters

Pattern Number	6
Pattern Name	COMPETITIVE 2
Mode	Clean & Oil
Forward Speed	Max Clean
Start Cleaner Spray	0
Start Squeegee	0
Start Oiling	6
Split Pattern	No

Supplies Information

Lane Cleaner	
Cleaner Mixture Ratio	: 1
Cleaner Transition Distance	43
Lane Conditioner	

Notes

Zone	1	2	3	4	5	6	7	8
Zone End Distance	8	15	23	32	41			
Zone Ratio	L 1.8 : 1 R 1.8 : 1	L 1.8 : 1 R 1.8 : 1	L 1.9 : 1 R 1.9 : 1	L 1.8 : 1 R 1.8 : 1	L 1.0 : 1 R 1.0 : 1	### : 1 ### : 1	### : 1 ### : 1	### : 1 ### : 1

ZONE	7 Pin Side							Board Number							10 Pin Side																							
	L1	L2	L3	L4	L5	L6	L7	L8	L9	L10	L11	L12	L13	L14	L15	L16	L17	L18	L19	C20	R19	R18	R17	R16	R15	R14	R13	R12	R11	R10	R9	R8	R7	R6	R5	R4	R3	R2
1	20	20	20	20	55	55	55	55	55	30	30	30	30	30	30	75	75	75	75	75	75	30	30	30	30	30	30	30	30	55	55	55	55	55	20	20	20	20
2	16	16	16	16	40	40	40	40	40	27	27	27	27	27	27	55	55	55	55	55	55	27	27	27	27	27	27	27	27	40	40	40	40	40	16	16	16	16
3	12	12	12	12	30	30	30	30	30	22	22	22	22	22	22	45	45	45	45	45	45	22	22	22	22	22	22	22	22	30	30	30	30	30	12	12	12	12
4	9	9	9	9	24	24	24	24	24	15	15	15	15	15	15	33	33	33	33	33	33	15	15	15	15	15	15	15	15	24	24	24	24	24	9	9	9	9
5	1	1	1	1	1	1	1	1	1	1	1	1	1	1	1	1	1	1	1	1	1	1	1	1	1	1	1	1	1	1	1	1	1	1	1	1	1	
6																																						
7																																						
8																																						

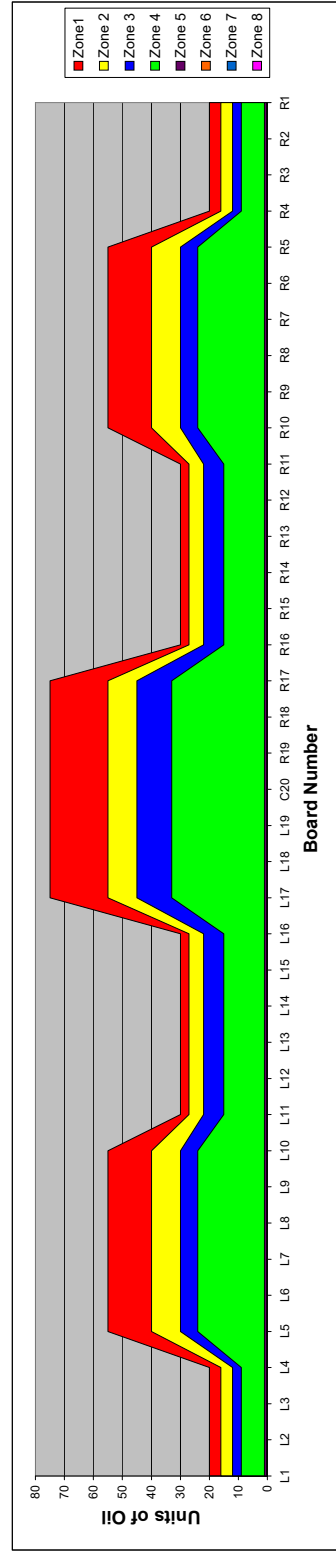

Pattern Information

Date:

Pattern Type:

Pattern Difficulty:

Pattern Designer:

Pattern Parameters

Pattern Number:

Pattern Name:

Mode:

Forward Speed:

Start Cleaner Spray:

Start Squeegee:

Start Oiling:

Split Pattern:

Supplies Information

Lane Cleaner:

Cleaner Mixture Ratio:

Cleaner Transition Distance:

Lane Conditioner:

Surface Information

Surface Type:

Surface Brand:

Age:

Notes

Zone	1	2	3	4	5	6	7	8
Zone End Distance	6	11	17	22	29	32	38	8
Zone Ratio	L 1.3 : 1 R 1.3 : 1	L 1.4 : 1 R 1.4 : 1	L 1.6 : 1 R 1.6 : 1	L 2.3 : 1 R 2.3 : 1	L 2.4 : 1 R 2.4 : 1	L 2.4 : 1 R 2.4 : 1	L 1.0 : 1 R 1.0 : 1	### : 1 ### : 1

ZONE	7 Pin Side								10 Pin Side																														
	L1	L2	L3	L4	L5	L6	L7	L8	L9	L10	L11	L12	L13	L14	L15	L16	L17	L18	C20	R19	R18	R17	R16	R15	R14	R13	R12	R11	R10	R9	R8	R7	R6	R5	R4	R3	R2	R1	
1	30	30	36	50	64	75	79	80	80	80	80	80	82	82	82	82	82	82	82	82	80	80	80	80	80	80	80	80	80	80	79	75	64	50	36	30	30		
2	28	28	32	40	51	62	70	72	72	72	72	72	74	74	74	74	74	74	74	74	74	74	74	74	74	72	72	72	72	72	70	62	51	40	32	28	28		
3	22	22	23	30	38	46	54	59	61	61	61	61	63	63	63	63	63	63	63	63	61	61	61	61	61	61	61	61	61	61	59	54	46	38	30	23	22	22	
4	18	18	18	18	20	23	26	30	35	40	46	48	48	48	48	48	50	50	50	50	50	50	50	50	48	48	48	48	48	48	48	48	48	48	48	48	48	48	48
5	15	15	15	15	16	17	18	21	24	28	32	36	39	39	39	40	40	40	40	40	40	40	40	40	40	40	40	40	40	40	40	40	40	40	40	40	40	40	40
6	10	10	10	10	11	11	12	14	16	18	20	22	24	24	26	26	26	27	27	27	27	27	27	27	26	26	26	26	26	26	26	26	26	26	26	26	26	26	26
7	1	1	1	1	1	1	1	1	1	1	1	1	1	1	1	1	1	1	1	1	1	1	1	1	1	1	1	1	1	1	1	1	1	1	1	1	1	1	
8																																							

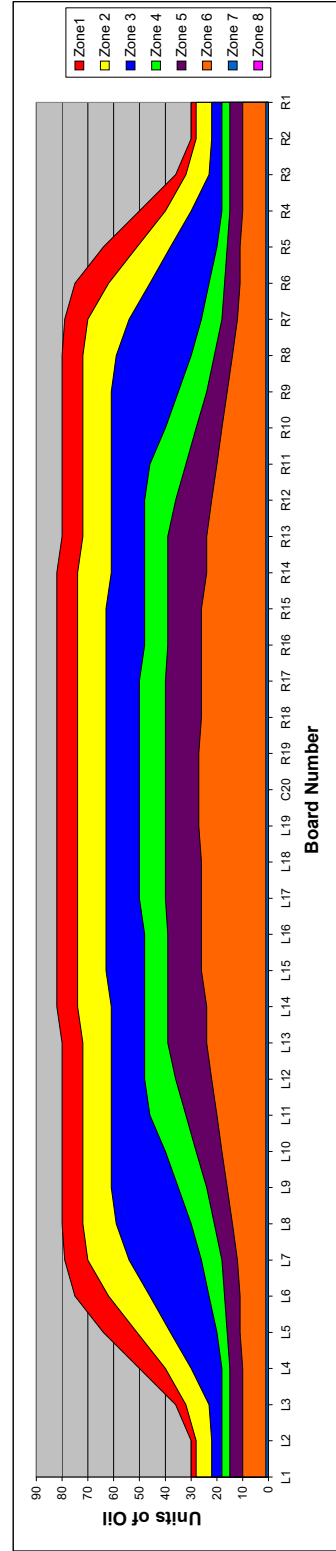



AUTHORITY22[®]

Pattern Information

Date:

Pattern Type:

Pattern Difficulty:

Pattern Designer:

Surface Information

Surface Type:

Surface Brand:

Age:

Pattern Parameters

Pattern Number:

Pattern Name:

Mode:

Forward Speed:

Start Cleaner Spray:

Start Squeegee:

Start Oiling:

Split Pattern:

Notes

Notes:

Supplies Information

Lane Cleaner:

Cleaner Mixture Ratio:

Cleaner Transition Distance:

Lane Conditioner:

Zone	1	2	3	4	5	6	7	8
Zone End Distance	<input type="text" value="7"/>	<input type="text" value="13"/>	<input type="text" value="19"/>	<input type="text" value="26"/>	<input type="text" value="33"/>	<input type="text" value="39"/>	<input type="text" value="46"/>	<input type="text" value="53"/>
Zone Ratio	L: <input type="text" value="1.8 : 1"/> R: <input type="text" value="1.8 : 1"/>	L: <input type="text" value="1.7 : 1"/> R: <input type="text" value="1.7 : 1"/>	L: <input type="text" value="1.7 : 1"/> R: <input type="text" value="1.7 : 1"/>	L: <input type="text" value="1.7 : 1"/> R: <input type="text" value="1.7 : 1"/>	L: <input type="text" value="1.8 : 1"/> R: <input type="text" value="1.8 : 1"/>	L: <input type="text" value="1.8 : 1"/> R: <input type="text" value="1.8 : 1"/>	L: <input type="text" value="1.8 : 1"/> R: <input type="text" value="1.8 : 1"/>	L: <input type="text" value="1.8 : 1"/> R: <input type="text" value="1.8 : 1"/>

ZONE	7 Pin Side							10 Pin Side																														
	L1	L2	L3	L4	L5	L6	L7	L8	L9	L10	L11	L12	L13	L14	L15	L16	L17	L18	L19	C20	R19	R18	R17	R16	R15	R14	R13	R12	R11	R10	R9	R8	R7	R6	R5	R4	R3	R2
1	23	28	32	37	40	44	47	51	54	57	60	63	66	68	70	72	72	73	73	73	72	72	70	70	68	66	63	60	57	54	51	47	44	40	37	32	28	23
2	19	24	28	31	35	38	41	45	48	50	53	55	57	58	60	61	61	62	62	62	61	61	60	60	58	57	55	53	50	48	45	41	38	35	31	28	24	19
3	16	20	23	25	28	31	33	35	37	39	40	42	44	45	47	47	48	48	49	49	49	48	48	47	45	44	42	40	39	37	35	33	31	28	25	23	20	16
4	12	14	17	19	22	24	26	28	29	31	32	34	35	36	37	37	38	38	38	37	37	37	36	35	34	32	31	29	28	26	24	22	19	17	14	12		
5	9	10	12	14	15	17	19	20	21	22	23	25	26	26	27	28	28	29	29	29	29	28	28	27	26	25	23	22	21	20	19	17	15	14	12	10	9	
6	0	0	0	0	0	0	0	0	0	0	0	0	0	0	0	0	0	0	0	0	0	0	0	0	0	0	0	0	0	0	0	0	0	0	0	0	0	
7																																						
8																																						

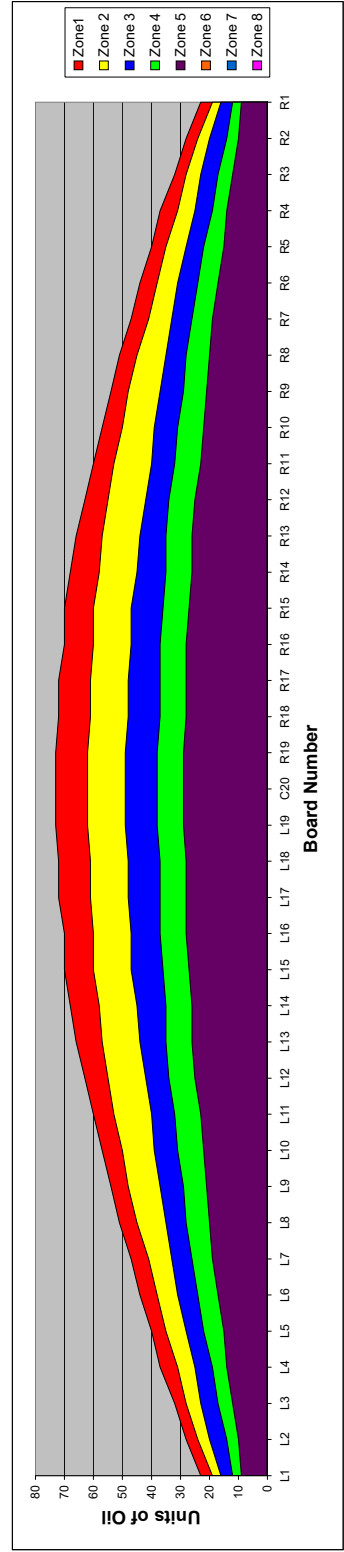

10. Pattern - Sport Flat

Pattern Information

Date	
Pattern Type	Sport
Pattern Difficulty	High
Pattern Designer	Brunswick

Pattern Parameters

Pattern Number	10
Pattern Name	SPORT 1-1
Mode	Clean & Oil
Forward Speed	Max Clean
Start Cleaner Spray	0
Start Squeegee	0
Start Oiling	6
Split Pattern	Yes

Supplies Information

Lane Cleaner	
Cleaner Mixture Ratio	: 1
Cleaner Transition Distance	44
Lane Conditioner	

Surface Information

Surface Type	
Surface Brand	
Age	

Notes

Zone	1	2	3	4	5	6	7	8
Zone End Distance	8	16	22	27	32	37	43	8

Zone Ratio	L	1.0 : 1	1.0 : 1	1.0 : 1	1.0 : 1	1.0 : 1	1.0 : 1	### : 1	### : 1
	R	1.0 : 1	1.0 : 1	1.0 : 1	1.0 : 1	1.0 : 1	1.0 : 1	### : 1	### : 1

ZONE	7 Pin Side							10 Pin Side																															
	L1	L2	L3	L4	L5	L6	L7	L8	L9	L10	L11	L12	L13	L14	L15	L16	L17	L18	L19	C20	R18	R17	R16	R15	R14	R13	R12	R11	R10	R9	R8	R7	R6	R5	R4	R3	R2	R1	
1	65	65	65	65	65	65	65	65	65	65	65	65	65	65	65	65	65	65	65	65	65	65	65	65	65	65	65	65	65	65	65	65	65	65	65	65	65	65	65
2	54	54	54	54	54	54	54	54	54	54	54	54	54	54	54	54	54	54	54	54	54	54	54	54	54	54	54	54	54	54	54	54	54	54	54	54	54	54	54
3	42	42	42	42	42	42	42	42	42	42	42	42	42	42	42	42	42	42	42	42	42	42	42	42	42	42	42	42	42	42	42	42	42	42	42	42	42	42	42
4	31	31	31	31	31	31	31	31	31	31	31	31	31	31	31	31	31	31	31	31	31	31	31	31	31	31	31	31	31	31	31	31	31	31	31	31	31	31	31
5	20	20	20	20	20	20	20	20	20	20	20	20	20	20	20	20	20	20	20	20	20	20	20	20	20	20	20	20	20	20	20	20	20	20	20	20	20	20	20
6	1	1	1	1	1	1	1	1	1	1	1	1	1	1	1	1	1	1	1	1	1	1	1	1	1	1	1	1	1	1	1	1	1	1	1	1	1	1	1
7	0	0	0	0	0	0	0	0	0	0	0	0	0	0	0	0	0	0	0	0	0	0	0	0	0	0	0	0	0	0	0	0	0	0	0	0	0	0	0
8																																							

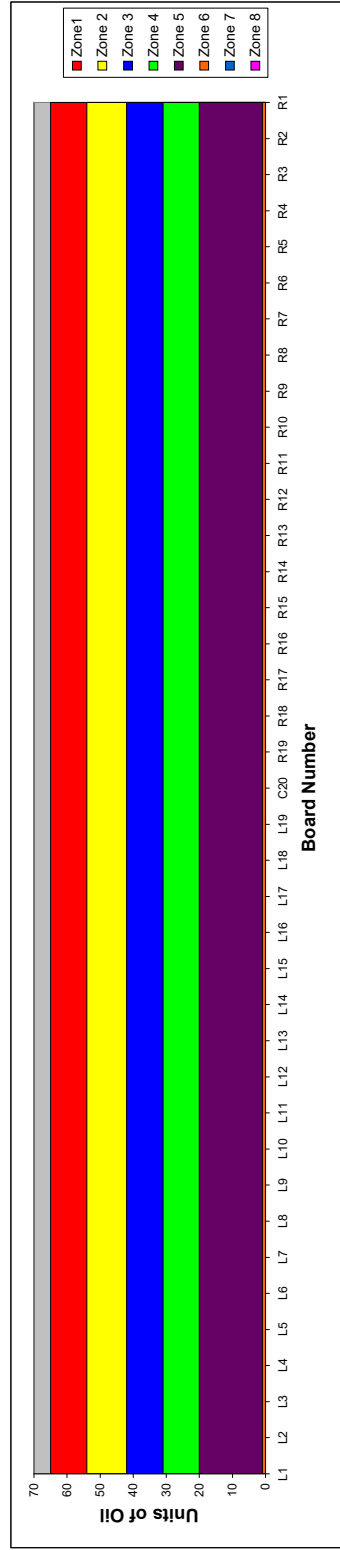

Appendix

This Appendix provides technical documentation that may be helpful for your general reference.

In this Appendix you will find:

1. Pre-Installation Packing List
2. A set of electrical schematics and diagrams

Pre-installation Packing List

These items should be shipped with the Authority22 Lane Machine. Please call us if you are missing any items on this packing list.

Lane Machine Complete with Covers and GUI

1. 125' (38.1m) Power Cord
2. Spare Parts Kit
3. Straight Edge Alignment Tool
4. Authority22 Operation & Service Manual

Spare Parts Kit (14-860224-000)

The Spare Parts Kit includes all items listed below. These items can also be ordered individually, with the part number provided.

- (1) 14-860213-000 AC Input Adapter Kit, GUI Package
- (1) 14-100487-000 Seal - Waste Tank, "D" Shape
- (2) 14-100427-000 Foam - Buffer Shield Drip
- (1) 11-655013-013 1/4" OD x 41.00" LG Polyurethane Tube
- (1) 11-655018-000 Union Elbow, 1/4" Tube Fitting
- (1) 11-112133-000 #2 Phillips with 10 " shank screwdriver
- (1) 11-112132-000 1/4" T-Handle Allen, Long
- (1) 11-112134-000 Dual Fuse Puller Tool
- (1) 14-100557-000 Buffer Shield Foam
- (1) 14-100202-000 Grease Fitting, Dispersion Roller
- (1) 14-860209-000 No Spill Spout Pkg with Cleaner Mixing Vessel
- (2) 11-655002-000 Cleaner Check Valve Strainer, 200 Mesh
- (2) 11-655003-000 Cleaner Spray Nozzle Tip
- (1) 11-616025-000 Duster up-down switch
- (1) 11-616026-000 Buffer/Squeegee up-down switch
- (1) 11-616031-000 Cord Kill Switch
- (1) 14-100378-000 Vacuum Diffuser Foam
- (1) 14-860214-000 Fuse, 4.0A, S50V Slow Blo, 5MM x 20MM (Package of 5)
- (1) 14-860215-000 Fuse, 3.25A, S50V Slow Blo, 5MM x 20MM (Package of 5)
- (1) 14-860216-000 Fuse, 10.0A, S50V Slow Blo, 5MM x 20MM (Package of 5)
- (1) 14-860217-000 Fuse, 8.0A, S50V Slow Blo, 5MM x 20MM (Package of 5)
- (1) 14-860218-000 Fuse, 6.3A, S50V Slow Blo, 5MM x 20MM (Package of 5)
- (1) 14-860219-000 Fuse, 2.9A, S50V Slow Blo, 5MM x 20MM (Package of 5)

Electrical Schematics & Diagrams

The following schematics and diagrams are provided for your reference:

1. Fuse Locations & Specifications and Output LED Locations
2. Overall Electrical System Schematic
3. Electronics Control Enclosure - 115V
4. Electronics Control Enclosure - 230V
5. Overall GUI Schematic
6. GUI & Handle Keypad Schematic

11 x 17 Fold out Page
Fuse Locations & Specifications and Output LED Locations

Intentionally Blank

11 x 17 Foldout Page
Overall Electrical System Schematic

Intentionally Blank

11 x 17 Foldout Page
Electronics Control Enclosure - 115V

Intentionally Blank

11 x 17 Foldout Page
Electronics Control Enclosure - 230V

Intentionally Blank

11 x 17 Foldout Page
Overall GUI Schematic

Intentionally Blank

11 x 17 Foldout Page
GUI & Handle Keypad Schematic