

Pre-Installation Manual

StringPin Pinsetter
with Electrical Requirements

January 2021 / 10-095400-079

Brunswick StringPin Pinsetter Electrical Requirements Pre-Installation Manual

© January 2021 by the Brunswick Bowling Products. All rights reserved.

Manual Part No. 10-095400-079

Notice: If available, updates to this manual can be found on-line at www.brunswickbowling.com.

Confidential proprietary information. All information contained in this document is subject to change without notice.

Brunswick Bowling Products
525 West Laketon Avenue
Muskegon, MI 49443
U.S.A.

231.725.3300

CONTENTS

Introduction	6
Interference Information	6
Surge Suppression	6
Wiring Requirements	6
Wiring Method	6
Grounding	6
Pinsetter Guarding Options	7
European Union Countries	7
Non-European Union Countries.....	8
Electrical Overview.....	9
Electrical Sub-Panel Specifications.....	9
Sub-panel and Surge Suppressor Installation.....	11
Three Phase Power Panel	11
Single Phase Power Panel	12
Selecting a Surge Suppressor	13
StringPin Pinsetter Overview (Rear Mount Controller).....	14
StringPin Pinsetter Overview (Front Mount Controller)	16
StringPin Pinsetter Lane Dimensions.....	18
StringPin Pinsetter Area	19
Bowling Foundation Construction	20
Lane Foundation Dimensions	20
Power Outlet Information	21
StringPin Controller	21
StringPin Controller (Rear Mount)	22
StringPin Controller (Front Mount)	23
StringPin Controller Wiring	24
Internal - UL Version.....	24
Internal - CE Version.....	25
Input Power - 208-230 Volt.....	27
Input Power - With Phase Converter.....	28

IMPORTANT!

The information in this manual is a guide.

All local codes will need to be considered during the design and building process.

i *NOTE: Dimensions in this Guide have metric conversions and are expressed in meters to the third decimal point for any dimension over a meter and are expressed in millimeters for any dimension under a meter.*



i *NOTE: Designated specifications within the planning guide are required for customers within the European Union in order to comply with local, national and European health and safety regulations. Failure to follow these specifications will render the CE Declaration of Conformity and associated warranty null and void.*

NOTICE TO CUSTOMERS IN THE EUROPEAN UNION!

Brunswick's Declaration of Conformity to the Machinery Directive is provided subject to adherence to the specifications provided in this Guide.



***NOTE:** Specifications with the designated CE indicator are required for conformity with the European Union's Machinery Directive and are a prerequisite to Brunswick's provisioning of the Declaration of Conformity and related warranty. Customers who elect to deviate from the designated specifications forfeit Brunswick's warranty in relation to compliance to the Machinery Directive and they take full responsibility for complying with European, national, regional and local regulations. Customers who elect to take these deviations are advised to consult with local worker's health and safety experts before construction.*

INTRODUCTION

This document contains the information necessary for the preparation of a site conforming to Brunswick specifications. It is very important the site complies with the requirements specified in the following pages. Any deviations from these specifications could cause problems to your equipment that may be difficult to detect and/or correct.

INTERFERENCE INFORMATION



CAUTION!

This equipment generates, uses, and can radiate radio frequency energy and if not installed and used in accordance with the installation manual, may cause interference to radio communications. It has been tested and found to comply with the limits for a Class A computing device pursuant to Subpart J of Part 15 of FCC rules, which are designed to provide reasonable protection against such interference when operated in a commercial environment. Operation of this equipment in a residential area is likely to cause interference in which case the user, at his own expense, will be required to take whatever measures may be required to correct the interference.

SURGE SUPPRESSION

A transient voltage suppressor (TVSS) is NOT supplied with the pinsetter system, but is suggested. The installation of this TVSS is the responsibility of the customer through a licensed electrician. The TVSS will be located at the pinsetter sub-panel that supplies the electronics. This TVSS is designed for the most demanding environment and incorporates multistage filtration in its design. The Sine Wave tracking series is engineered to remove the more complex disturbances found in the electrical environment, in particular, high and low voltage ringing transients and harmonic activity.



NOTE: *The surge suppressor wires should be as short as possible, with no coiling when installed on the pinsetter sub-panel. The TVSS is provided with a plastic coupler to insulate the unit from the sub-panel.*

WIRING REQUIREMENTS

Wiring Method

The pinsetter control boxes require a permanent wiring connection to the AC supply using rigid conduit. Use of flexible cord for connection to these boxes is not sufficient.

Grounding

The pinsetter must be connected to a grounded, metal, permanent wiring system; or an equipment-grounding conductor must be run with the circuit conductors and connected to the equipment-grounding terminal on the control box.

PINSETTER GUARDING OPTIONS

European Union Countries



LOCAL GUARDING (CE Certified) -
Required for customers in the European Union

- A. 360 degree security perimeter
- B. Rear Machine/Ball Accelerator Guards
- C. Front masking unit panel (required)
- D. Rear Machine Guards
- E. Top/Motor Drive Guards
- F. Rear Pinfall Guards
- G. Side Pinfall Guards
- H. Ball Accelerator Guard
- J. Front Table Guard (not shown)
- K. Pin Station Guard (not shown)

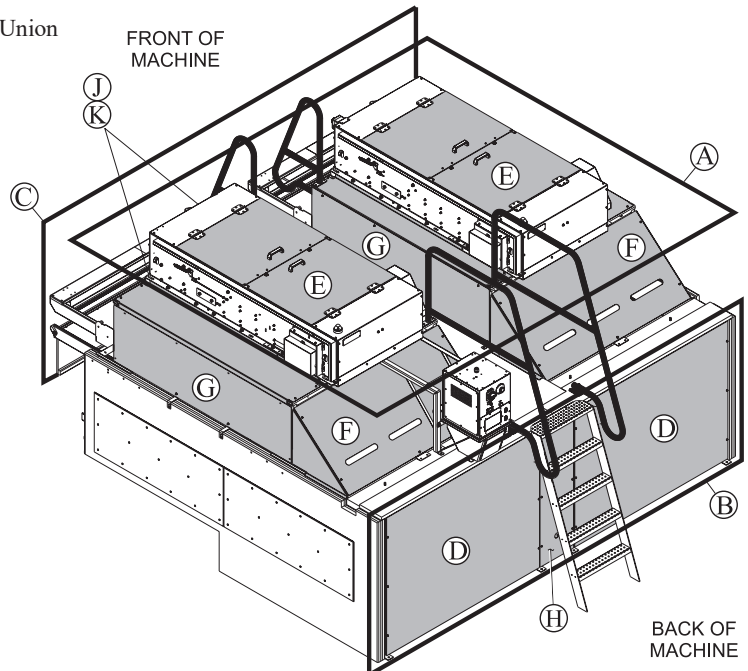

Non-European Union Countries



Brunswick strongly encourages customers to consider upgrading to Brunswick's Advanced Guarding (CE Certified) system.

UL GUARDING (UL Certified) -
Required for customers located outside the
European Union

- A. Rear Machine Guards
- B. Front masking unit panel (required)
- C. Top/Motor Drive Guards
- D. Pin Station Guards

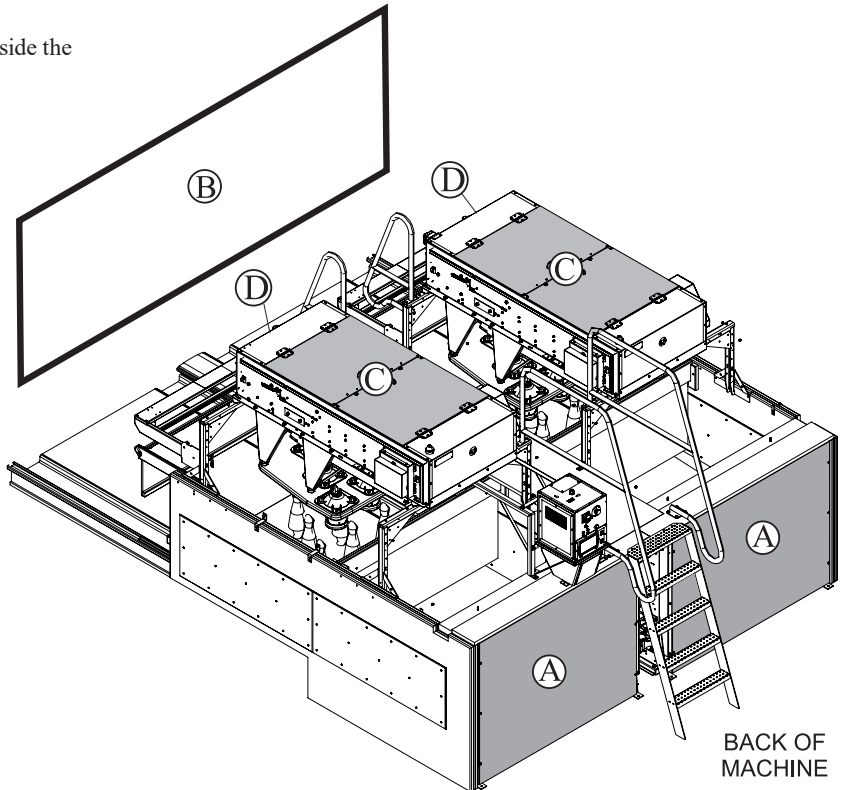

LOCAL GUARDING (CE Certified) -
Required for customers in the European Union
& residential installations

- A. 360 degree security perimeter
- B. Rear Machine/Ball Accelerator Guards
- C. Front masking unit panel (required)
- D. Rear Machine Guards
- E. Top/Motor Drive Guards
- F. Rear Pinfall Guards
- G. Side Pinfall Guards
- H. Ball Accelerator Guard
- J. Front Table Guard (not shown)
- K. Pin Station Guard (not shown)

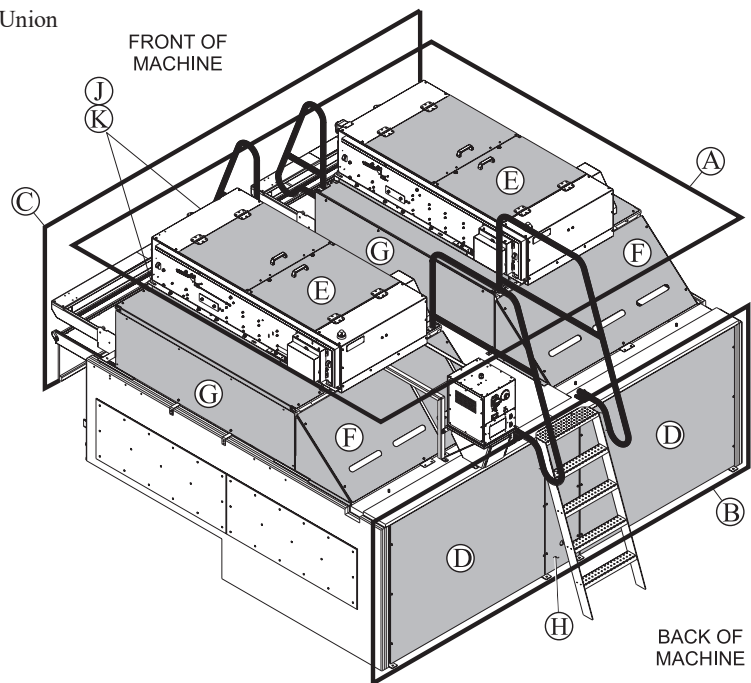

Electrical Overview

ELECTRICAL SUB-PANEL SPECIFICATIONS

i **IMPORTANT!:** *All sub-panels and wiring MUST comply with local and national electrical codes.*

Pinsetter Sub-panel – The Pinsetter sub-panel used to power the StringPin pinsetters and other Brunswick equipment must be powered directly from the primary main service sub-panel or transformer. Non-Brunswick equipment including electronic video games, arc welders, HVAC, compressors, etc., cannot share this sub-panel.

Scoring Sub-panel – The scoring sub-panel must be powered from the main service sub-panel or transformer. Non-Brunswick equipment including electronic video games, arc welders, HVAC, compressors, etc., cannot share this sub-panel.

The **ONLY** type of equipment to be installed in the sub-panels:

Pinsetter Sub-panel

- StringPin Pinsetter
- Ball Lift
- Tel-E-Foul
- Lane Machine
- Ball Polisher
- Lightworx
- Lanescape Video Masking Unit
- Ticket Depot

Scoring Sub-panel

- Scoring Computer
- Peripheral Controllers
- Sync Table Power Supply
- 32”/43”/49”/55” Overhead Monitors
- Display Controller
- HD Video Distribution Center
- Server Computer
- Client Computer
- Automated - Pinball Wizard
- Digital Signage



WARNING! *Any Non-Brunswick equipment circuits located in these sub-panels will VOID ALL WARRANTY. This includes electronic video games, arc welders, HVAC, compressors, etc.*

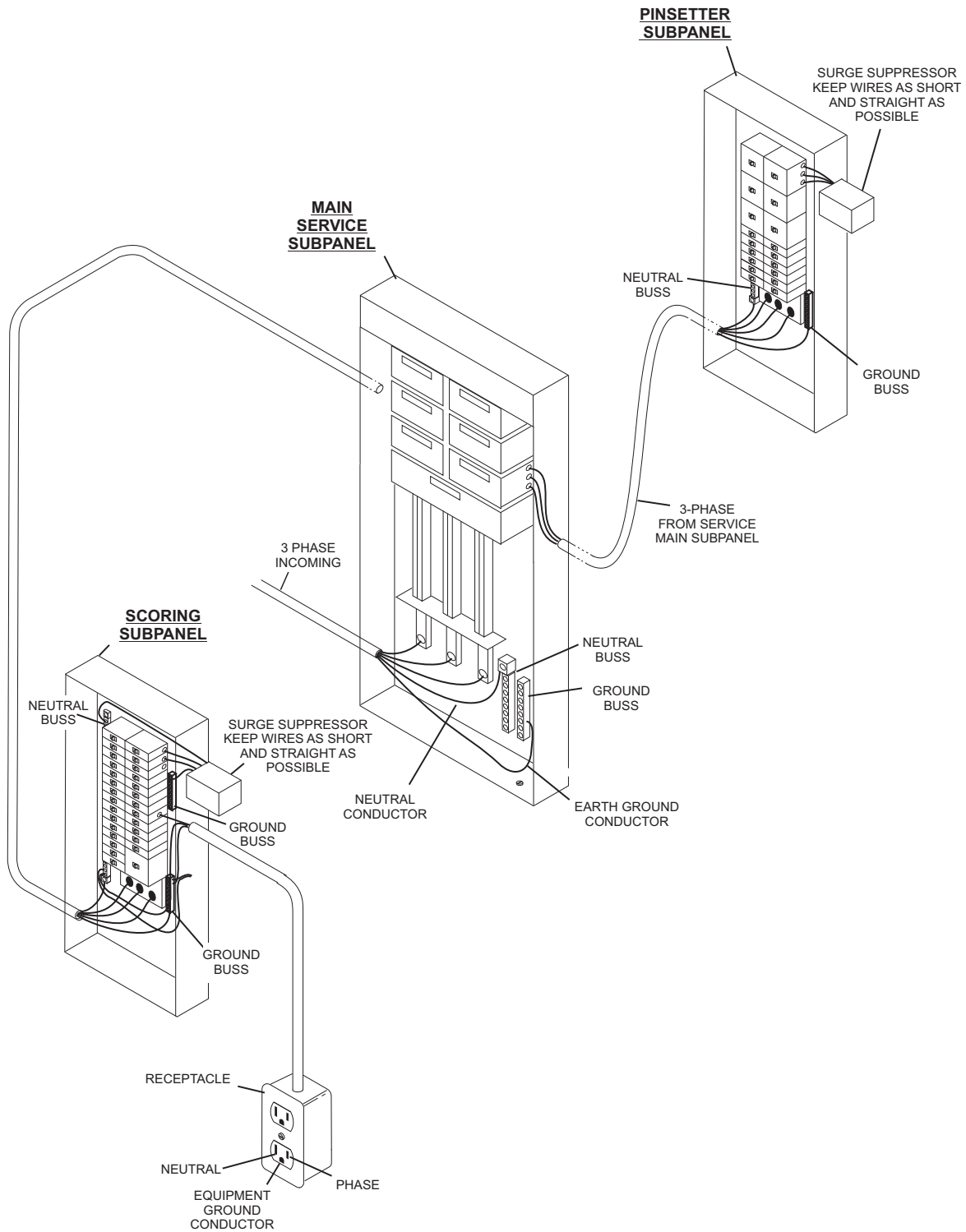

Figure 1

i IMPORTANT!: Split house centers with multiple sub-panels require a single source of power and ground from main service.

SUB-PANEL AND SURGE SUPPRESSOR INSTALLATION

Three Phase Power Panel

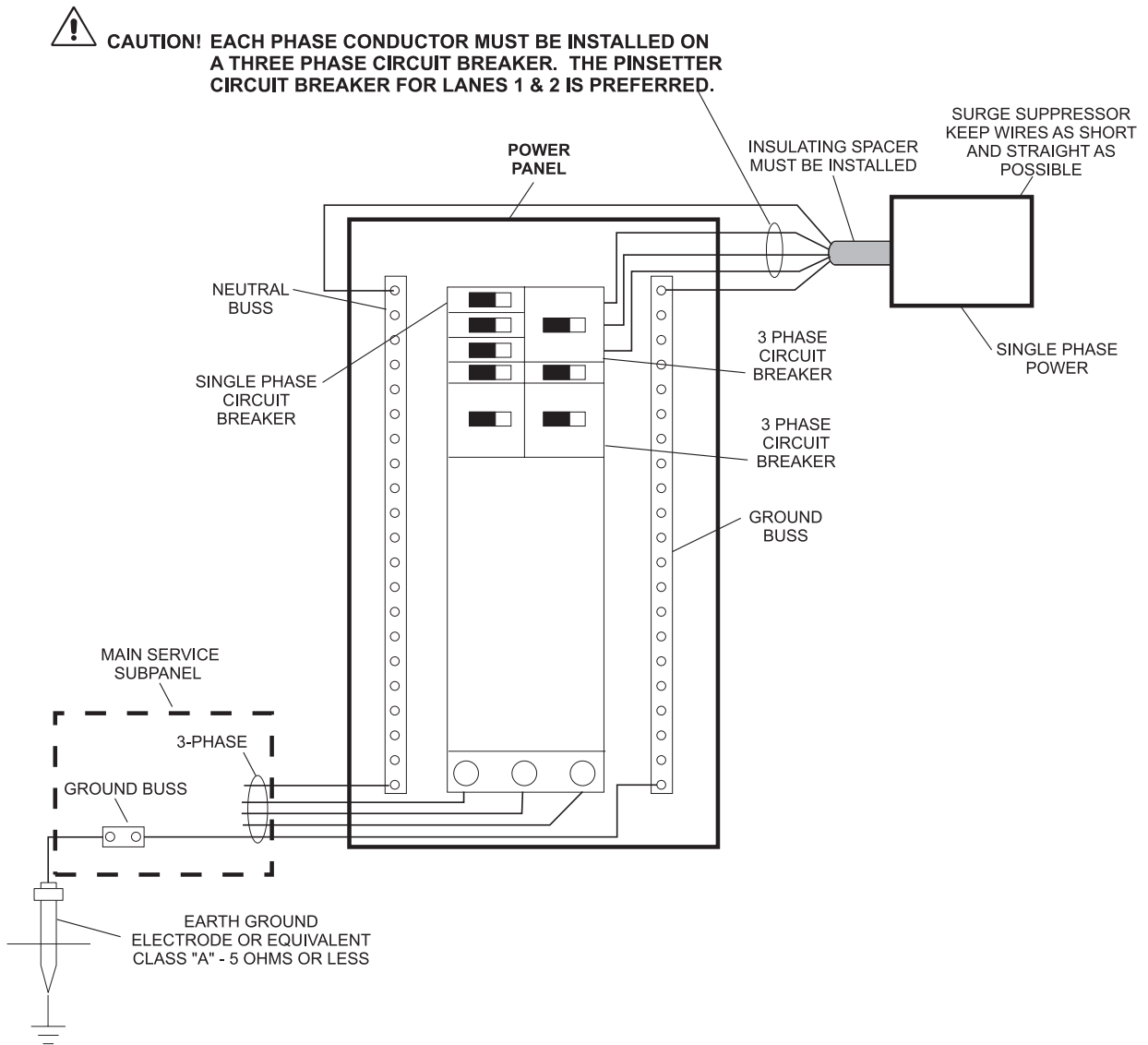

Figure 2

Single Phase Power Panel

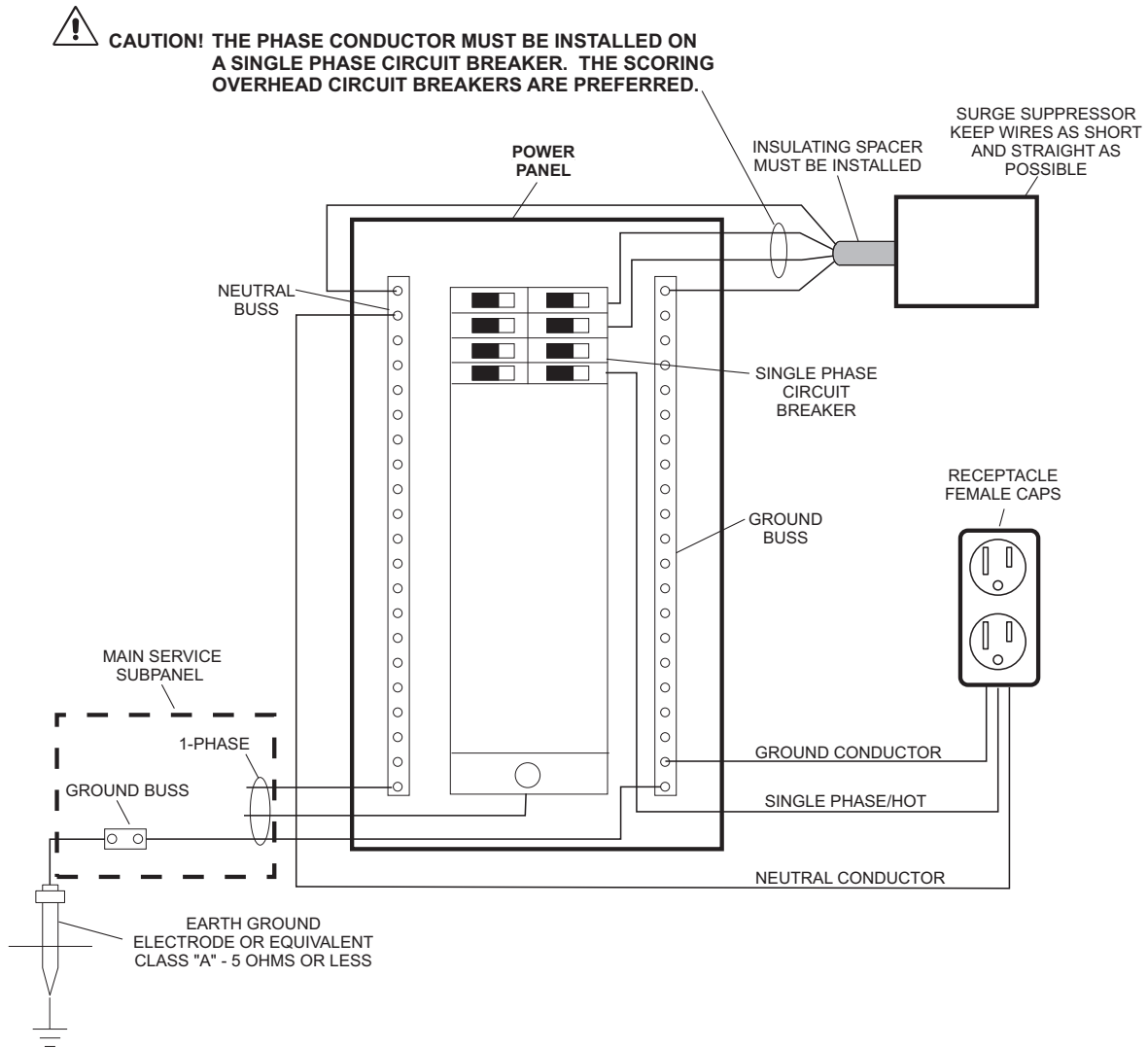
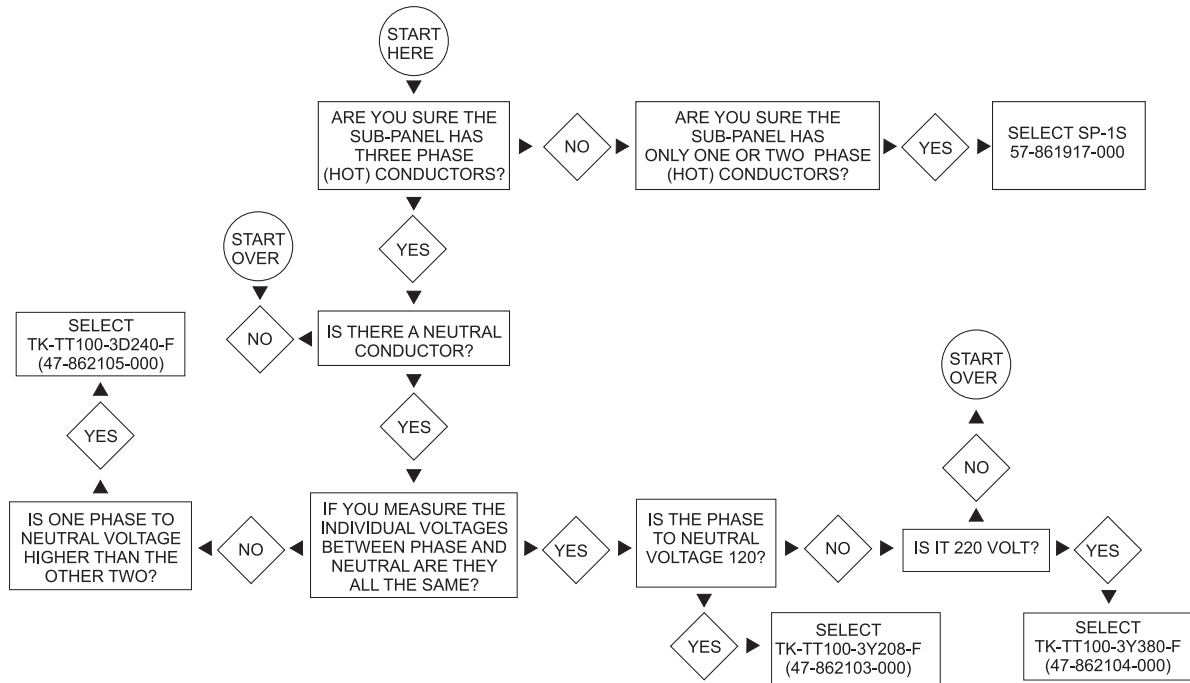

Figure 3

SELECTING A SURGE SUPPRESSOR

A flow chart diagram is shown below to assist you in identifying which surge suppressor is needed.

Model	Voltage/Phase	Wye/Delta	No. of Wires	Brunswick Part No.
TK-TT100-3Y208-F	120/208 Three	Wye	4 Wire + Ground	47-862103-000
TK-TT100-3D240-F	120/240 Three	Delta	4 Wire + Ground	47-862105-000
TK-TT100-3Y380-F	220/380 Three	Wye	4 Wire + Ground	47-862104-000
TK-TT160-1S240-FB	120/240 Single	Wye	3-wire = Ground	57-861917-000



StringPin Pinsetter Overview (Rear Mount Controller)

WITH CURTAIN WALL / MASKING UNIT

ONE (1) STRING PIN CONTROLLER IS USED PER PAIR OF LANES AND WHEN LOCATED TO THE BACK OF THE MACHINE, IS MOUNTED TO THE BALL RETURN SIDE OF THE EVEN (RIGHT) LANE.

ELECTRICIAN TO HARD WIRE POWER CABLE INTO STRINGPIN CONTROLLER USING DROP CORD OR RIGID CONDUIT PER LOCAL CODE.

THE STRINGPIN CONTROLLER BOXES MUST BE CONNECTED TO A GROUNDED, METAL, PERMANENT WIRING SYSTEM; OR AN EQUIPMENT-GROUNDING CONDUCTOR MUST BE RUN WITH THE CIRCUIT CONDUCTORS AND CONNECTED TO THE EQUIPMENT-GROUNDING TERMINAL ON THE CONTROL BOX.

ALL ELECTRICAL CONNECTIONS MUST COMPLY WITH LOCAL CODE OF THE AREA IN WHICH THE PINSETTER IS BEING INSTALLED.

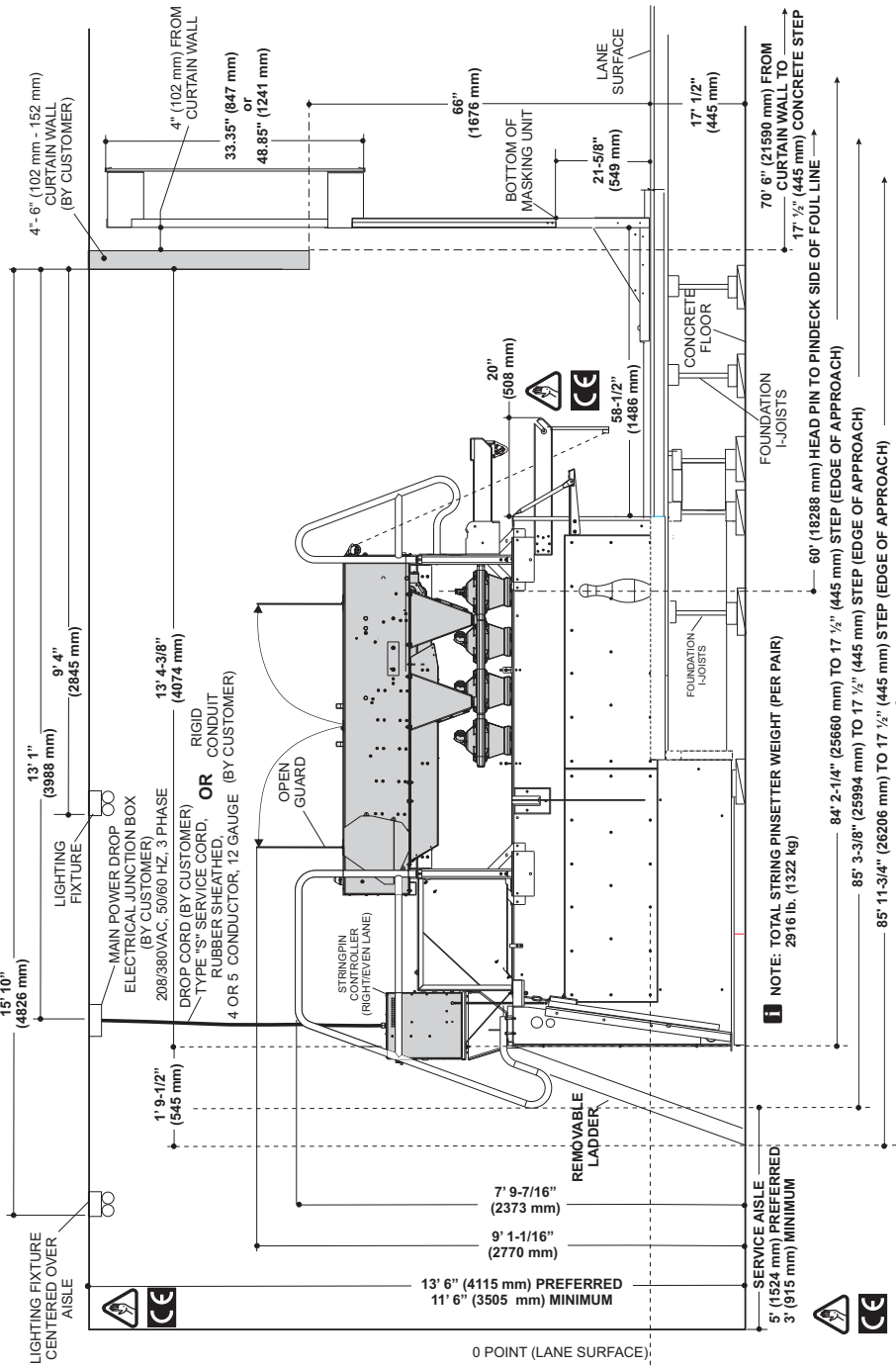

NOTE: TOTAL STRING PINSETTER WEIGHT (PER PAIR)
2916 lb. (1322 kg)

84' 2-1/4" (25660 mm) TO 17 1/2" (445 mm) STEP (EDGE OF APPROACH)

85' 3-3/8" (25994 mm) TO 17 1/2" (445 mm) STEP (EDGE OF APPROACH)

85' 11-3/4" (26206 mm) TO 17 1/2" (445 mm) STEP (EDGE OF APPROACH)

WARNING: CUSTOMERS SHOULD VALIDATE THAT THE SPECIFICATIONS OR ANY DEVIATIONS FROM THESE SPECIFICATIONS COMPLY WITH LOCAL REGULATIONS.

NOTE: Adherence to the designated specifications are required for compliance with the Machinery Directive.

Figure 4

WITH MASKING WALL

ONE (1) STRING PIN CONTROLLER IS USED PER PAIR OF LANES AND WHEN LOCATED TO THE BACK OF THE MACHINE, IS MOUNTED TO THE BALL RETURN SIDE OF THE EVEN (RIGHT) LANE
 ELECTRICIAN TO HARD WIRE POWER CABLE INTO STRINGPIN CONTROLLER USING DROP CORD OR RIGID CONDUIT PER LOCAL CODE.
 THE STRINGPIN CONTROLLER BOXES MUST BE CONNECTED TO A GROUNDED METAL PERMANENT WIRING SYSTEM; OR AN EQUIPMENT-GROUNDING CONDUCTOR MUST BE RUN WITH THE CIRCUIT CONDUCTORS AND CONNECTED TO THE EQUIPMENT-GROUNDING TERMINAL ON THE CONTROL BOX.
 ALL ELECTRICAL CONNECTIONS MUST COMPLY WITH LOCAL CODE OF THE AREA IN WHICH THE PINSETTER IS BEING INSTALLED.

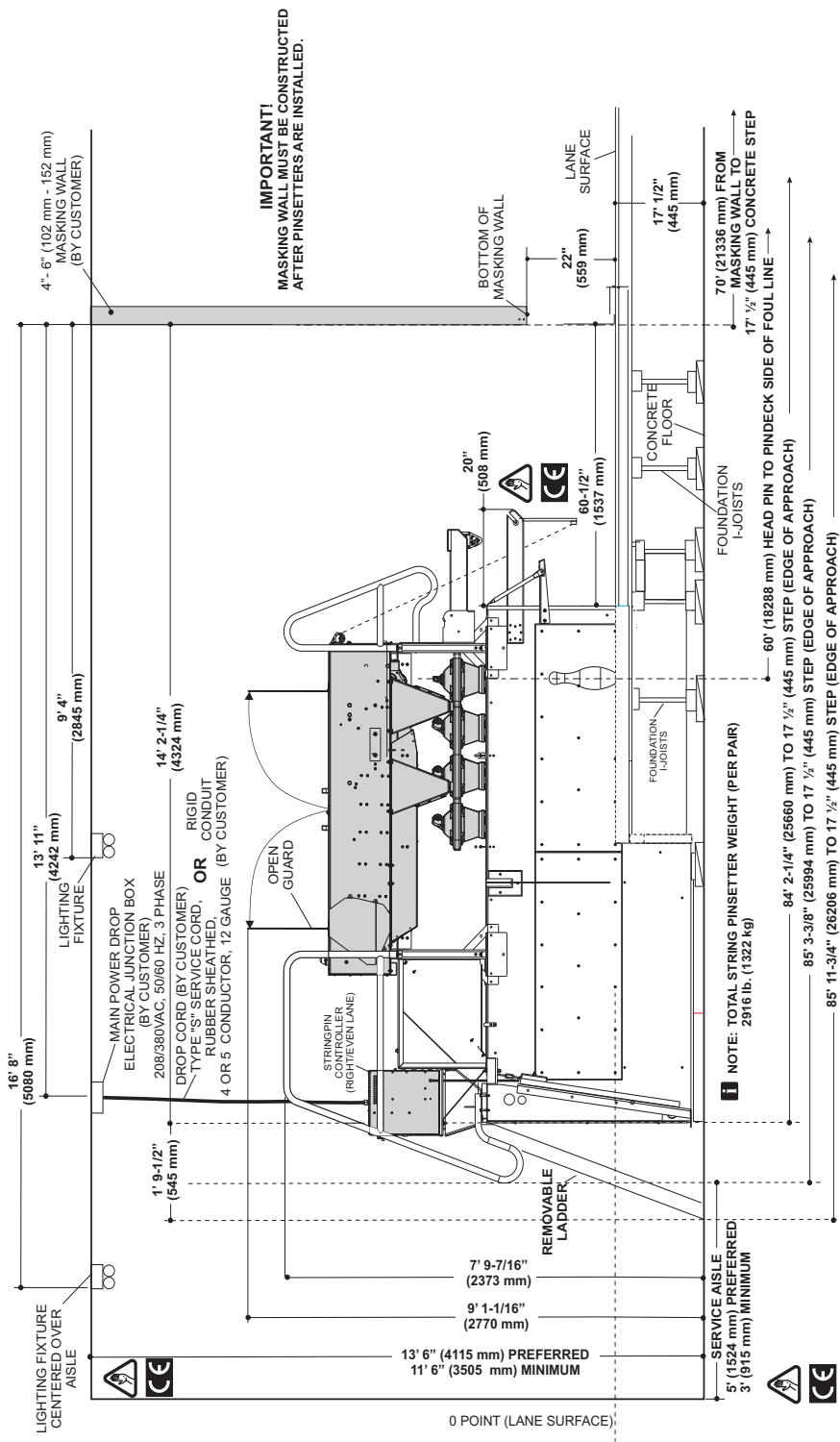

WARNING: CUSTOMERS SHOULD VALIDATE THAT THE SPECIFICATIONS OR ANY DEVIATIONS FROM THESE SPECIFICATIONS COMPLY WITH LOCAL REGULATIONS.

Figure 5

StringPin Pinsetter Overview (Front Mount Controller)

WITH CURTAIN WALL / MASKING UNIT

ONE (1) STRING PIN CONTROLLER IS USED PER PAIR OF LANES AND WHEN LOCATED TO THE BACK OF THE MACHINE, IS MOUNTED TO THE BALL RETURN SIDE OF THE EVEN (RIGHT) LANE
 ELECTRICIAN TO HARD WIRE POWER CABLE INTO STRINGPIN CONTROLLER USING DROP CORD OR RIGID CONDUIT PER LOCAL CODE.
 THE STRINGPIN CONTROLLER BOX(ES) MUST BE CONNECTED TO A GROUNDED, METAL, PERMANENT WIRING SYSTEM; OR AN EQUIPMENT-GROUNDING CONDUCTOR MUST BE RUN WITH THE CIRCUIT CONDUCTORS AND CONNECTED TO THE EQUIPMENT-GROUNDING TERMINAL ON THE CONTROL BOX.
 ALL ELECTRICAL CONNECTIONS MUST COMPLY WITH LOCAL CODE OF THE AREA IN WHICH THE PINSETTER IS BEING INSTALLED.

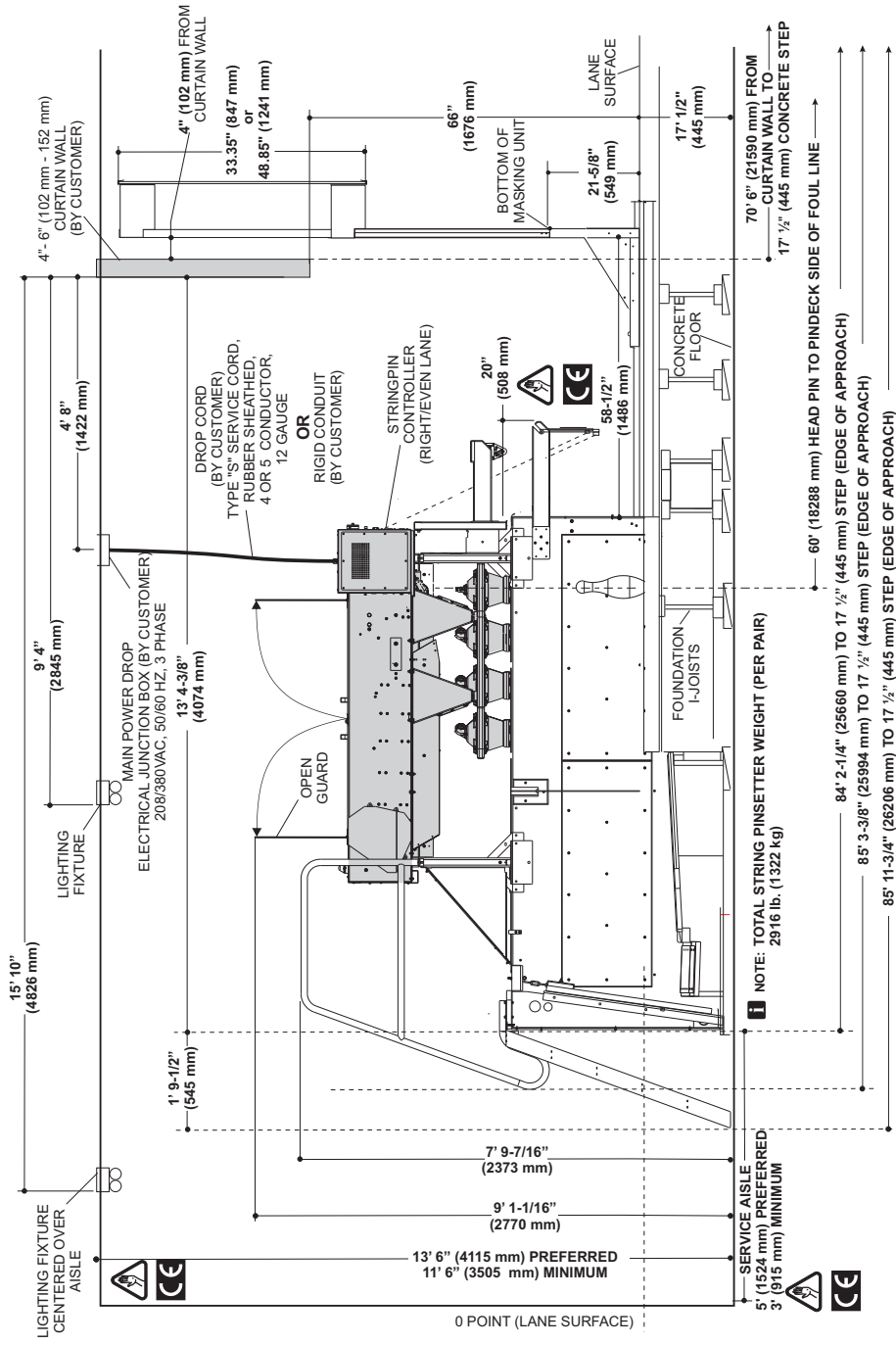

NOTE: Adherence to the designated specifications are required for compliance with the Machinery Directive.

WARNING: CUSTOMERS SHOULD VALIDATE THAT THE SPECIFICATIONS OR ANY DEVIATIONS FROM THESE SPECIFICATIONS COMPLY WITH LOCAL REGULATIONS.

Figure 6

WITH MASKING WALL

ONE (1) STRING PIN CONTROLLER IS USED PER PAIR OF LANES AND WHEN LOCATED TO THE BACK OF THE MACHINE, IS MOUNTED TO THE BALL RETURN SIDE OF THE EVEN (RIGHT) LANE

ELECTRICIAN TO HARD WIRE POWER CABLE INTO STRINGPIN CONTROLLER USING DROP CORD OR RIGID CONDUIT PER LOCAL CODE. THE STRINGPIN CONTROLLER BOX(IES) MUST BE CONNECTED TO A GROUNDED, METAL, PERMANENT WIRING SYSTEM; OR AN EQUIPMENT-GROUNDING CONDUCTOR MUST BE RUN WITH THE CIRCUIT CONDUCTORS AND CONNECTED TO THE EQUIPMENT-GROUNDING TERMINAL ON THE CONTROL BOX.

ALL ELECTRICAL CONNECTIONS MUST COMPLY WITH LOCAL CODE OF THE AREA IN WHICH THE PINSETTER IS BEING INSTALLED.

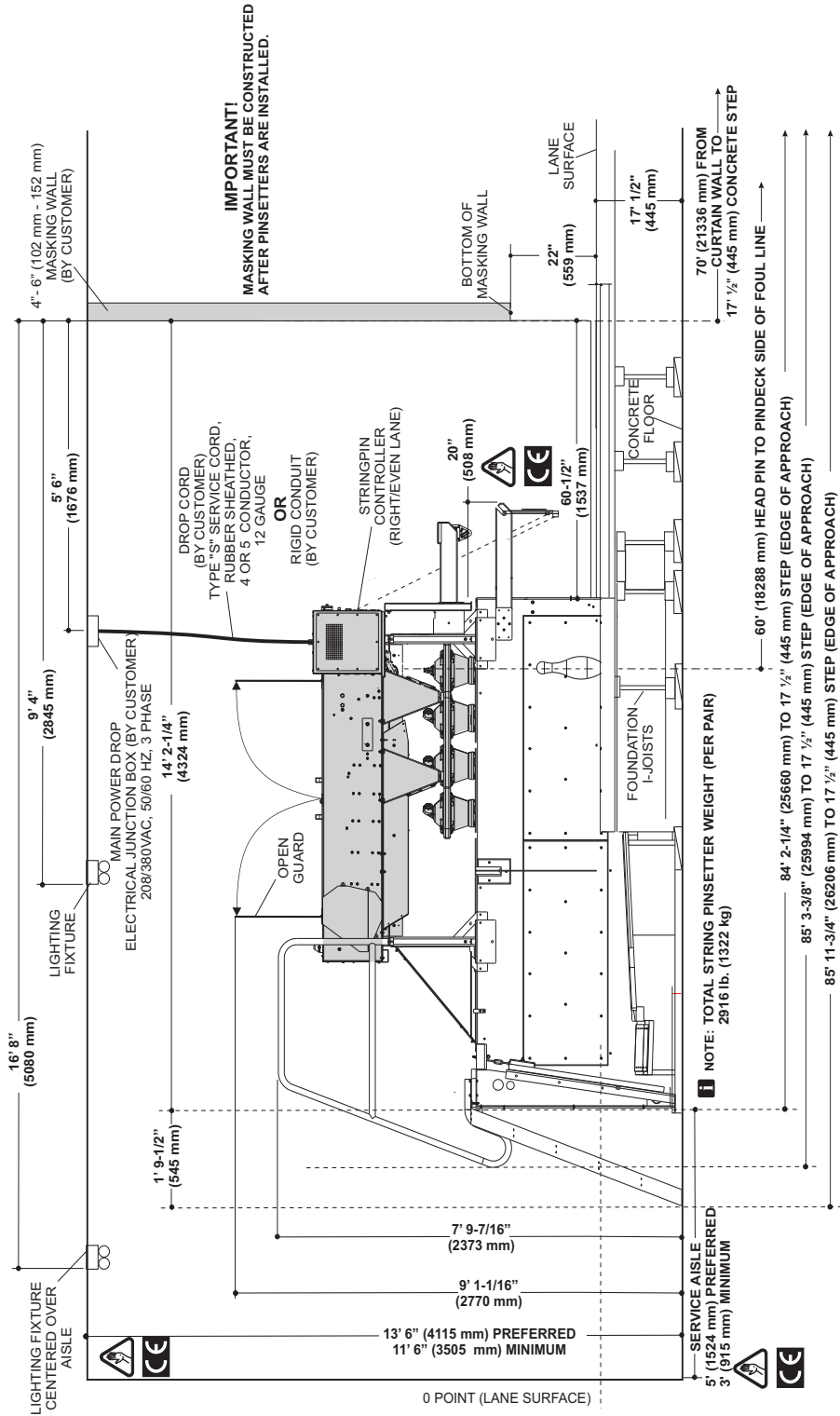

Figure 7

StringPin Pinsetter Lane Dimensions

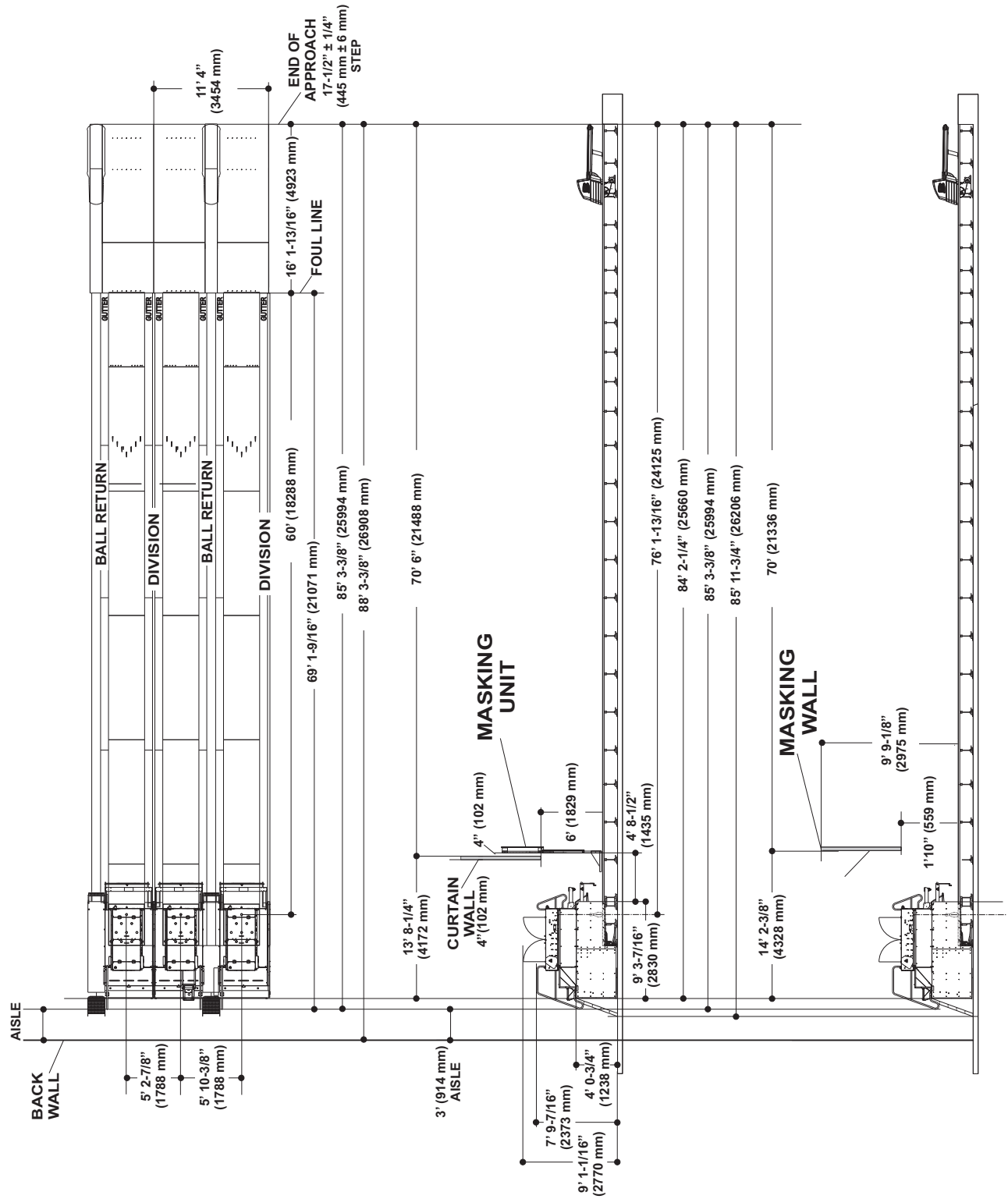
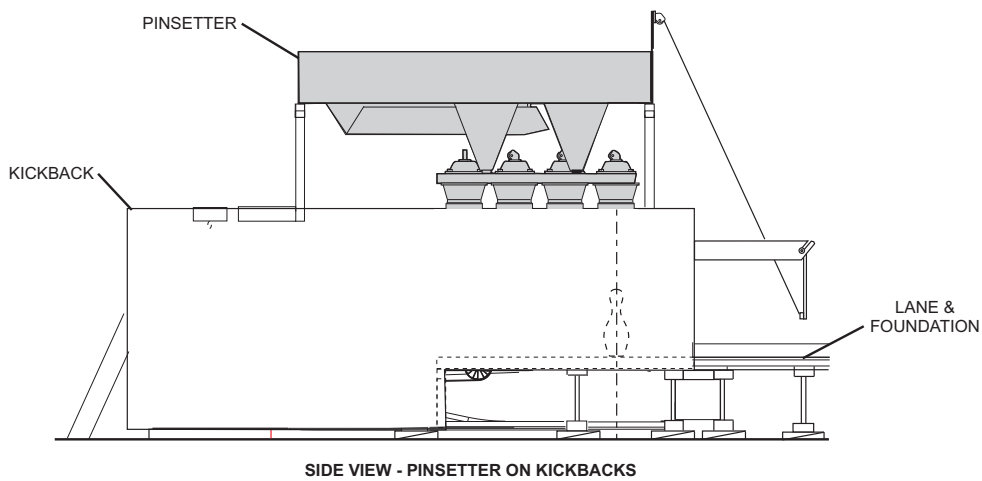
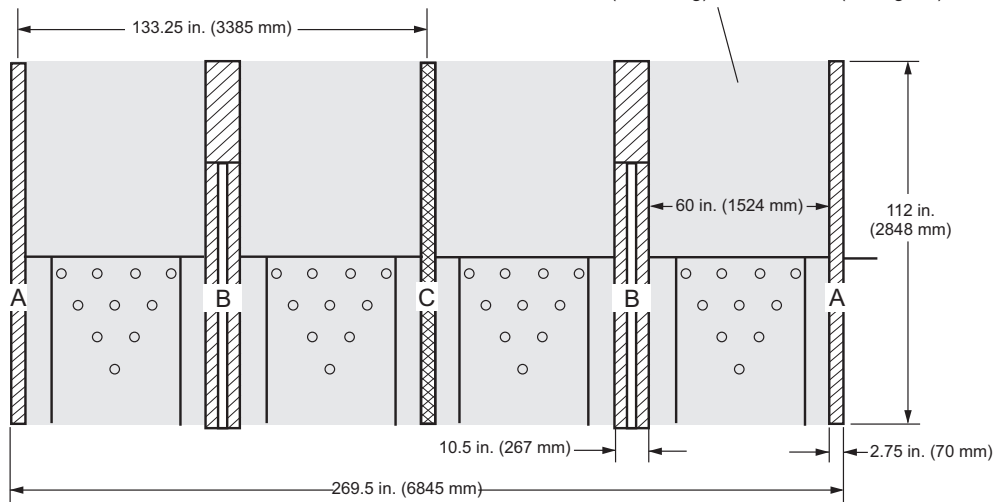

Figure 8

StringPin Pinsetter Area

i NOTE: AVERAGE EQUIPMENT LOAD FOR 4 LANES INCLUDING PIN DECKS WITH PINSETTER (112" X 269.5") IS 5920 lb (2685.3 kg) OR 28.5 lb/ft² (139 kg/m²).



LEGEND:

- "A" END DIVISION KICKBACK - LOADING OF 678 POUNDS (307 kg)
- "B" BALL ACCELERATOR KICKBACK - LOADING OF 1600 POUNDS (725 kg)
- "C" SHARED DIVISION KICKBACK - LOADING OF 1365 POUNDS (620 kg)

i NOTE: WEIGHT BEARING CAPACITY OF THE FLOOR WILL BE THE RESPONSIBILITY OF THE CUSTOMER. CUSTOMER MUST SECURE CERTIFICATION BY A REGISTERED ARCHITECT THAT THE BUILDING STRUCTURE IS ADEQUATE TO SUPPORT THE MACHINES.

Figure 9

BOWLING FOUNDATION CONSTRUCTION

Lane Foundation Dimensions

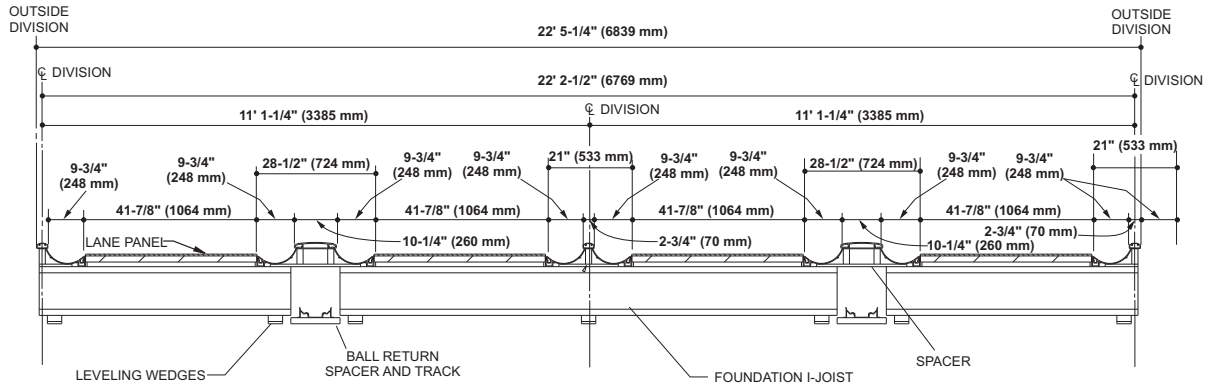

Figure 10 (End View)

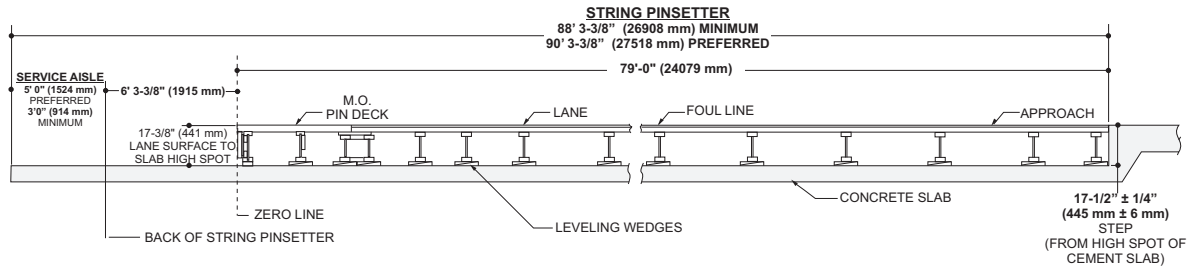

Figure 11 - String Pinsetter (Side View)

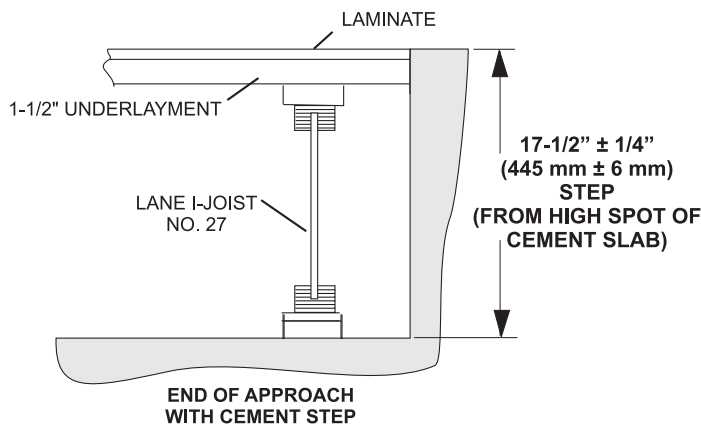

Figure 12 - Flush Approach Detail

POWER OUTLET INFORMATION

StringPin Controller

POWER REQUIREMENTS - STRINGPIN PINSETTER CONTROLLER (LANE PAIR)								
VOLTS	HERTZ	AC/DC	PHASE	AMP	WATTS	CIRCUIT REQUIREMENT	CUSTOMER RESPONSIBILITY	BRUNSWICK RESPONSIBILITY
380	50/60	AC	3	2.6	-	5 WIRES (3 LINE, 1 NEUTRAL AND 1 INSULATED GROUND (EARTH))	ALL POWER CABLING	-
208	50/60	AC	3	4.5	-	4 WIRES (3 LINE AND 1 INSULATED GROUND (EARTH))		

CIRCUIT REQUIREMENTS - STRINGPIN CONTROLLER				
NON-ISOLATED GROUND SUB PANEL	WIRES PER CIRCUIT	SUGGESTED LANE PAIRS PER CIRCUIT	WIRE SIZE	BREAKER SIZE
380VAC 3-PHASE	5 (INCLUDES GROUND (EARTH))	2	12 GAUGE	16A
208VAC 3 PHASE	4 (INCLUDES GROUND (EARTH))	2	12 GAUGE	20A

OUTLET LOCATION - STRINGPIN PINSETTER (PER LANE PAIR)
ONE JUNCTION BOX

StringPin Controller (Rear Mount)

NOTE: ALL POWER CABLING
IN THIS GRAPHIC IS THE
CUSTOMER'S RESPONSIBILITY

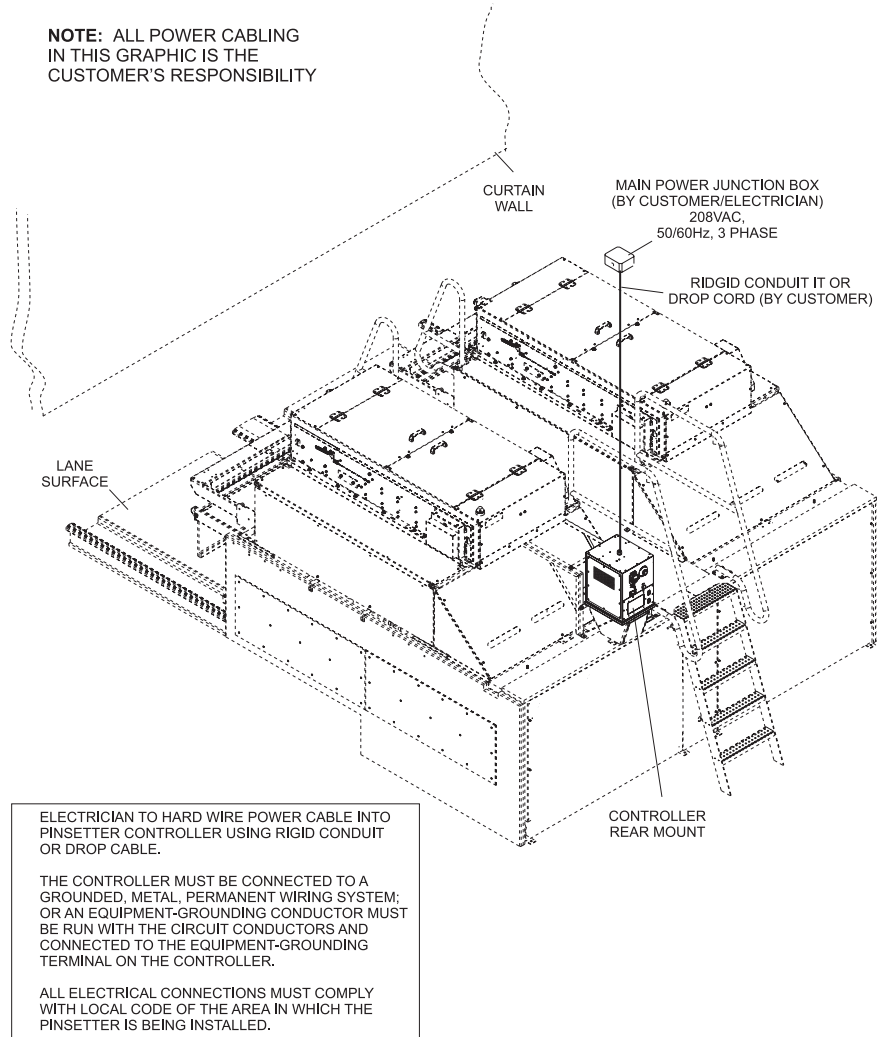

Figure 13

StringPin Controller (Front Mount)

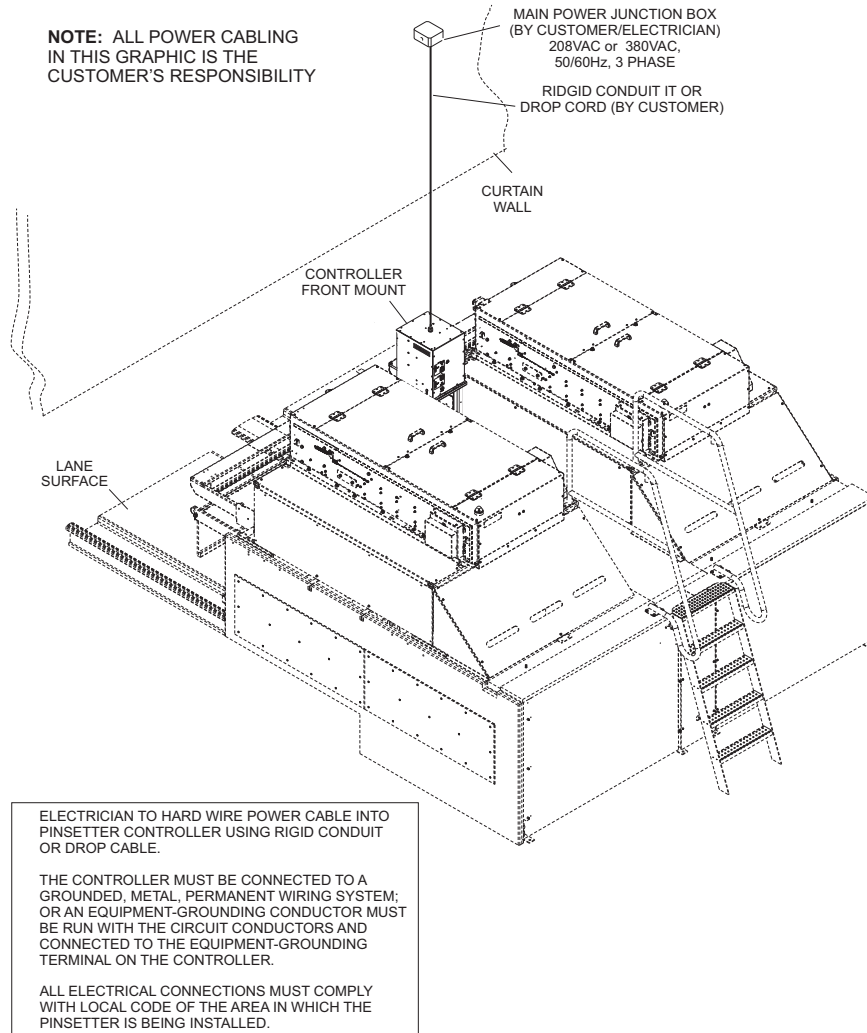
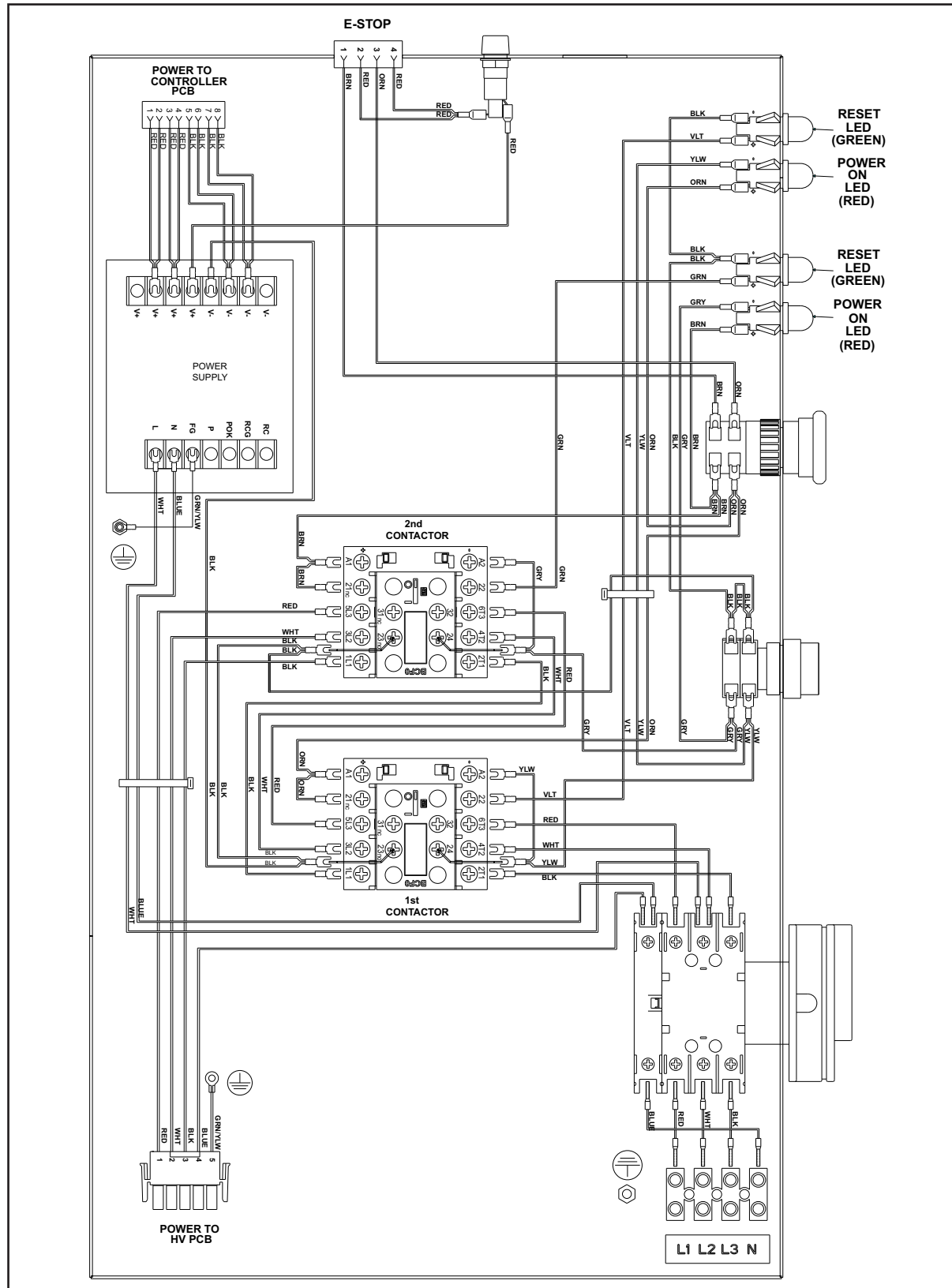

Figure 14

STRINGPIN CONTROLLER WIRING

Internal - UL Version



Internal - CE Version

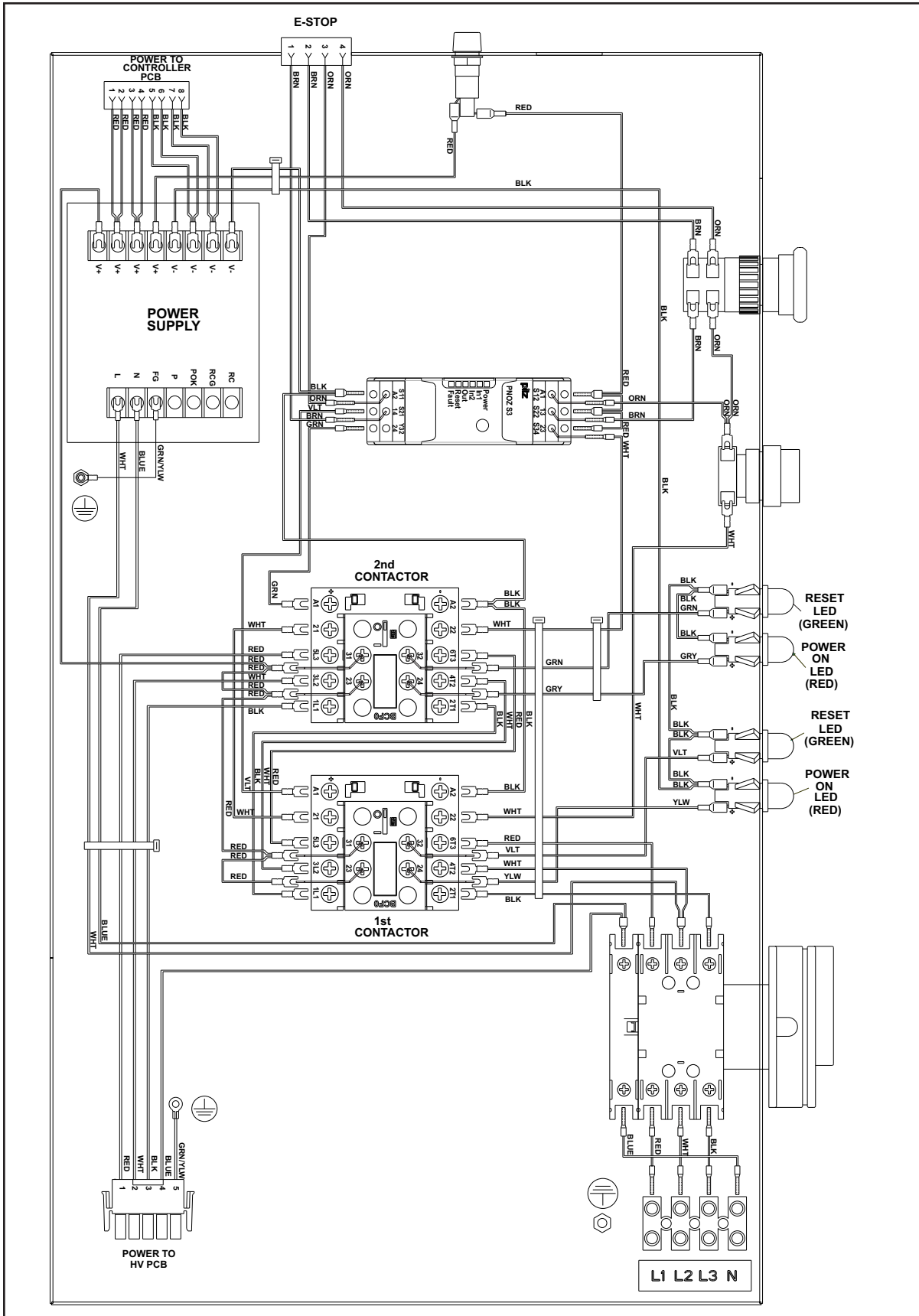

Input Power - 380 Volt

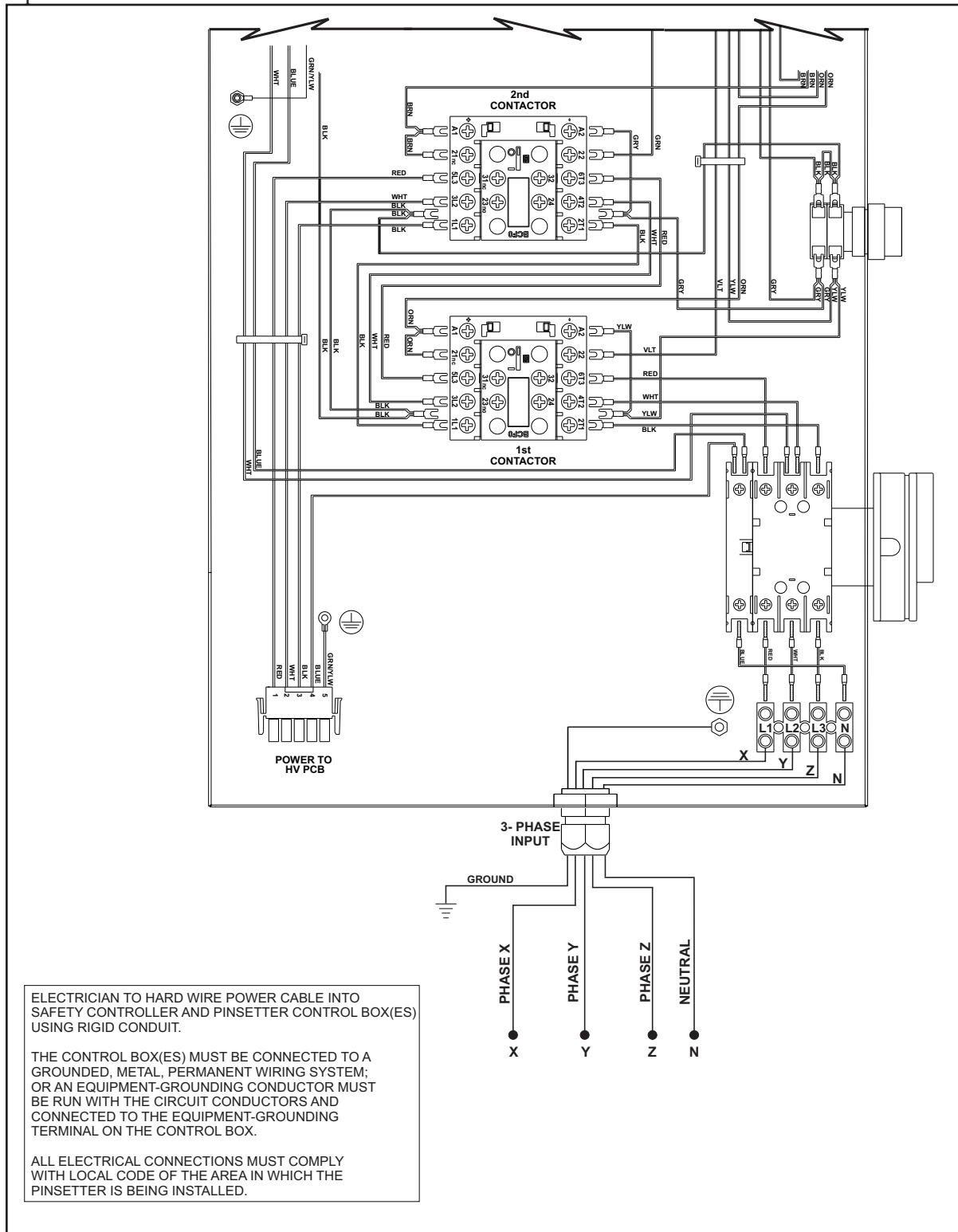

Input Power - 208-230 Volt

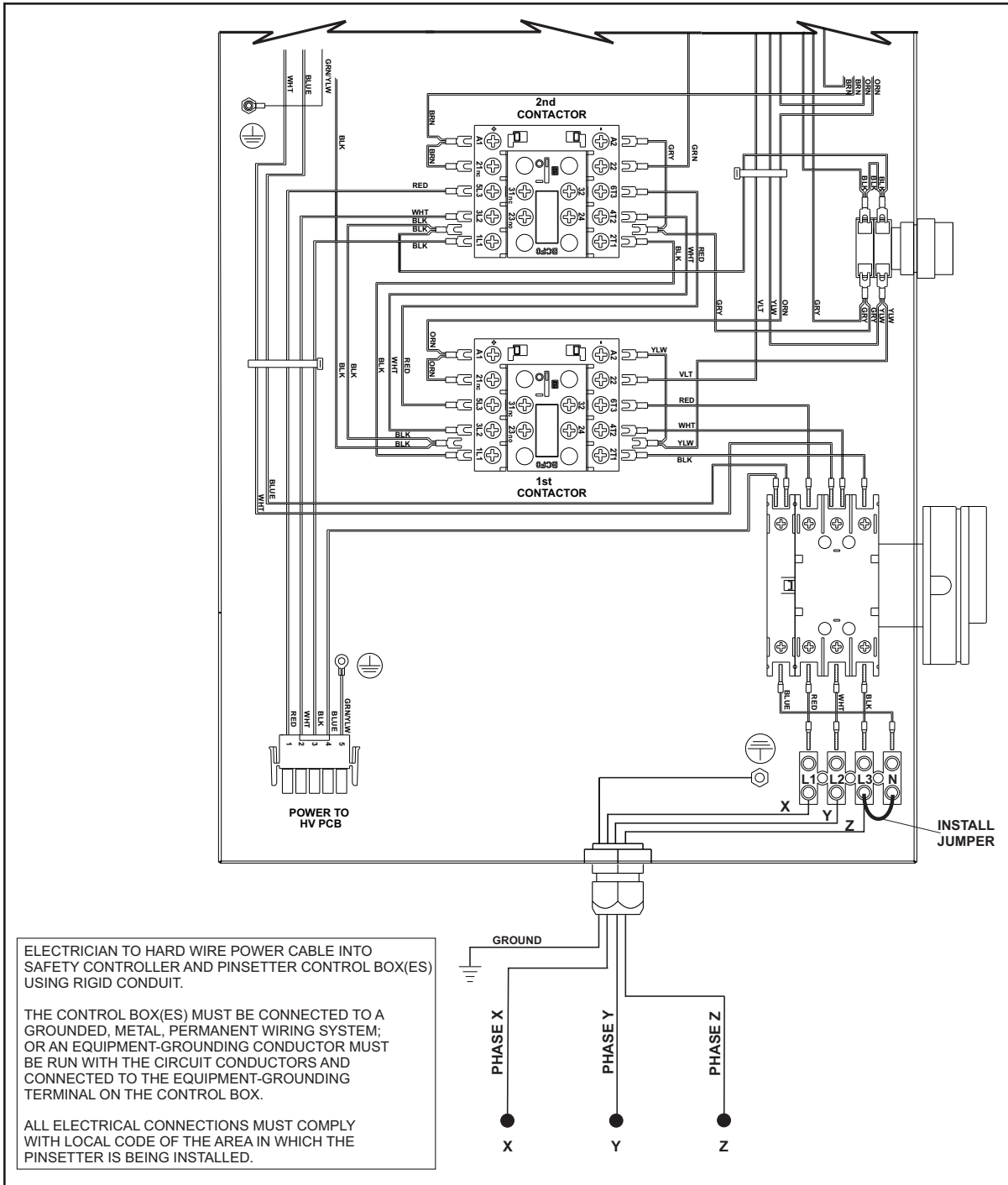

Input Power - With Phase Converter

